

LTC3554EPD

Micropower USB Power Manager with Two Step-Down Regulators

DESCRIPTION

Demonstration Circuit DC1468A is a Micropower USB Power Manager with Two Step-Down Regulators featuring the LTC[®]3554.

PERFORMANCE SUMMARY

Specifications are at $T_A = 25^\circ\text{C}$

| SYMBOL | PARAMETER | CONDITIONS | MIN | TYP | MAX | UNITS |
|--------|-------------------------|---|------|-----|------|-------|
| VBUS | Bus Input Voltage Range | | 4.35 | | 6 | V |
| V(BAT) | Battery Float Voltage | Constant Voltage Mode | 4.15 | | 4.23 | V |
| I(BAT) | Battery Charge Current | Constant Current Mode, $R_{\text{PROG}} = 1.87\text{k}$ | 420 | | 500 | mA |
| VOUT1 | Output Voltage 1 | $I(\text{VOUT1}) \leq 200\text{mA}$ | 3.25 | | 3.35 | V |
| VOUT2 | Output Voltage 2 | $I(\text{VOUT2}) \leq 200\text{mA}$ | 1.15 | | 1.25 | V |

QUICK START PROCEDURE

Refer to Figure 1 for the proper measurement equipment setup and jumper settings and follow the procedure below.

NOTE. When measuring the input or output voltage ripple, care must be taken to avoid a long ground lead on the oscilloscope probe. Measure the input or output voltage ripple by touching the probe tip directly across the VBUS or VOUT(x) and GND terminals. See Figure 2 for proper scope probe technique.

- Set PS1 = 0V, PS2 = 3.6V. Press “ON” button for > 0.5s. Observe I(BAT) (AM2), VOUT1 (VM5) and VOUT2 (VM6). The regulator ENable lines are low. Pressing the “ON” button turns on the regulators for 5s, via the pushbutton controller. The regulator ENables are bootstrapped to the outputs of the regulators, so regulators stay on indefinitely. The STBY jumper is on, so the LTC3554 draws only ~10 μA from the battery.
- Set STBY (JP4) to “OFF”, PS1 to 5V. Observe I(VBUS) (AM1), I(BAT) (AM2) and VPROG (VM2). The STBY jumper is off, and the battery charger is trying to charge the battery at 500mA, but the input current limit is keeping the charge current at 100mA.
- Set HPWR (JP2) to “500mA”. Observe I(VBUS) (AM1), I(BAT) (AM2) and VPROG (VM2). The input current limit is now 500mA, so the battery charger is charging at 450mA, and the buck regulators are unloaded.
- Set LD2 to 200mA, LD3 to 200mA. Observe VOUT1(VM5), VOUT2 (VM6) and I(BAT) (AM2). The buck regulators are each loaded at 200mA. These loads are reflected back to the VBUS input by the ratio of their output voltage to the VOUT Voltage. The buck regulators are higher priority

than the battery charger, so the charger is only charging at the input current limit of 500mA minus the reflected buck regulator loads, ~200mA.

5. Set LD2 to 0A, LD3 to 0A. Press “OFF” button. Observe VOUT1 (VM5) and VOUT2 (VM6). The “OFF” button momentarily brings the ENable lines low, shutting regulators off. The battery charge current should now return to 450mA.
6. Reset the Jumpers to their default position.

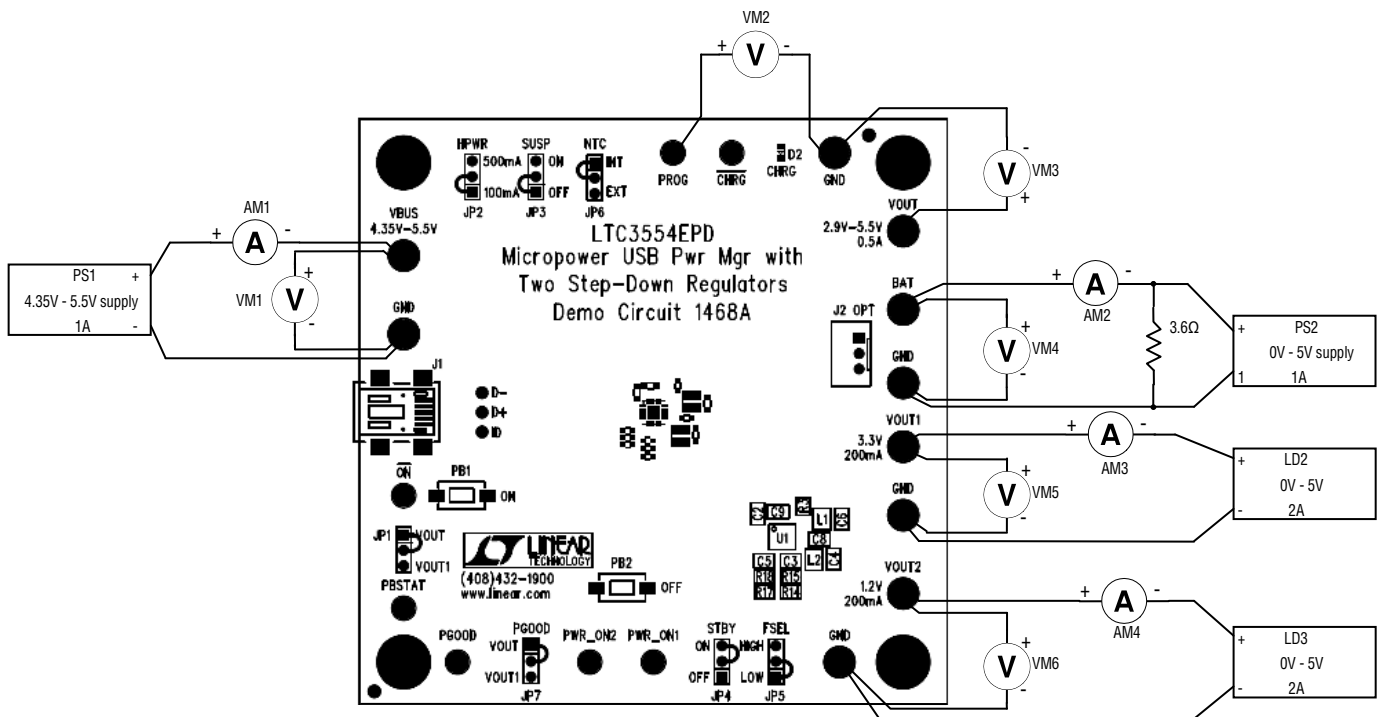

Note: All connections from equipment should be Kelvin connected directly to the board pins which they are connected on this diagram and any input or output leads should be twisted pair.

Figure 1. Proper Measurement Equipment Setup for DC1468A

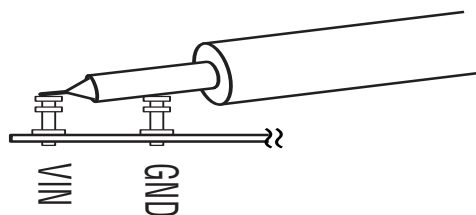

Figure 2. Measuring Input or Output Ripple

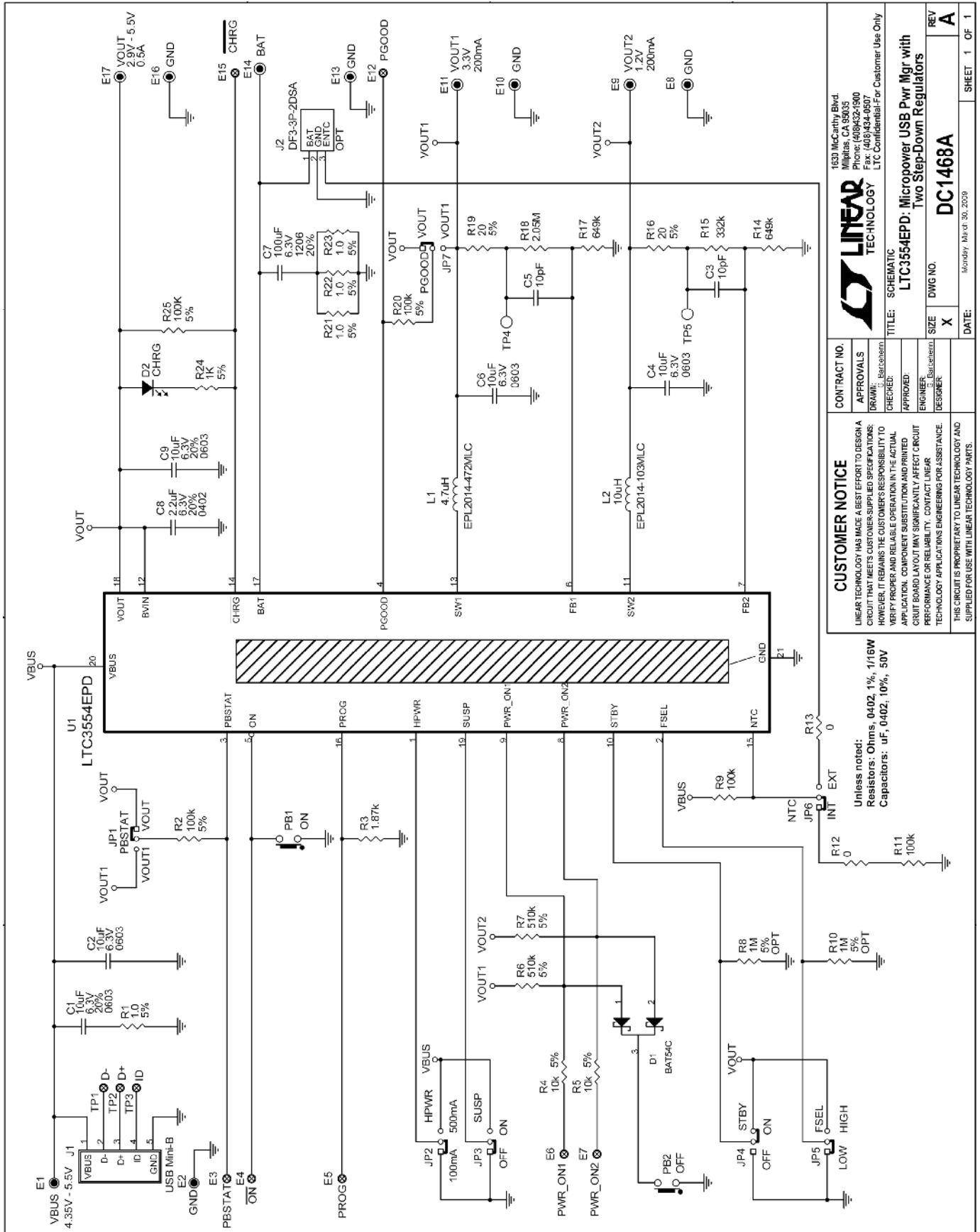

Figure 3. Circuit Schematic

| | | | |
|--|--|---|--|
| CONTRACT NO. APPROVALS DRAWN: [Signature] CHECKED: [Signature] ENGINEER: [Signature] DESIGNER: [Signature] | | DATE: Monday, Mar 30, 2009 | |
| CUSTOMER NOTICE LINEAR TECHNOLOGY HAS MADE A BEST EFFORT TO DESIGN A CIRCUIT THAT MEETS CUSTOMER-SUPPLIED SPECIFICATIONS; HOWEVER, IT REMAINS THE CUSTOMER'S RESPONSIBILITY TO VERIFY PROPER AND RELIABLE OPERATION IN THE ACTUAL APPLICATION. COMPONENT SUBSTITUTION AND PRINTED CIRCUIT BOARD LAYOUT MAY SIGNIFICANTLY AFFECT CIRCUIT PERFORMANCE OR RELIABILITY. CONTACT LINEAR TECHNOLOGY APPLICATIONS ENGINEERING FOR ASSISTANCE. THIS CIRCUIT IS PROPRIETARY TO LINEAR TECHNOLOGY AND SUPPLIED FOR USE WITH LINEAR TECHNOLOGY PARTS. | | REVISIONS: REV A DESCRIPTION: Micropower USB Pwr Mgr with Two Step-Down Regulators | |
| LINEAR TECHNOLOGY 1630 McCarthy Blvd. Milpitas, CA 95035-5000 Phone: 408.438.3500 Fax: 408.434.0507 LTC Confidential-For Customer Use Only | | DC1468A DWG NO. X SIZE X DATE: Monday, Mar 30, 2009 | |

| Qty | Reference | Part Description | Manufacture / Part # | |
|---|-----------|--|--|----------------------------|
| REQUIRED CIRCUIT COMPONENTS: | | | | |
| 1 | 4 | C2, C4, C6, C9 | CAP, CHIP, X5R, 10 μ F, \pm 10%, 6.3V, 0603 | TDK, C1608X5R0J106M |
| 2 | 2 | C3, C5 | CAP, CHIP, C0G, 10pF, \pm 5%, 25V, 0402 | VISHAY, VJ0402A100JXAA |
| 3 | 1 | C8 | CAP, CHIP, X5R, 2.2 μ F, \pm 20%, 6.3V, 0402 | MURATA, GRM155R60J225ME15D |
| 4 | 1 | L1 | IND, SMT, 4.7 μ H, 254m Ω , \pm 20%, 1.02A, 1.8mmX2mm | COILCRAFT, EPL2014-472MLB |
| 5 | 1 | L2 | IND, SMT, 10 μ H, 459m Ω , \pm 20%, 0.631A, 1.8mmX2mm | COILCRAFT, EPL2014-103MLB |
| 6 | 1 | R3 | RES, CHIP, 1.87k Ω , \pm 1%, 1/16W, 0402 | VISHAY, CRCW04021K87FKED |
| 7 | 2 | R9, R11 | RES, CHIP, 100k Ω , \pm 1%, 1/16W, 0402 | VISHAY, CRCW0402100KFKED |
| 8 | 2 | R12, R13 | RES, CHIP, 0 Ω jumper, 1/16W, 0402 | VISHAY, CRCW04020000Z0ED |
| 9 | 2 | R14, R17 | RES, CHIP, 649k Ω , \pm 1%, 1/16W, 0402 | VISHAY, CRCW0402649KFKED |
| 10 | 1 | R15 | RES, CHIP, 332k Ω , \pm 1%, 1/16W, 0402 | VISHAY, CRCW0402332KFKED |
| 11 | 1 | R18 | RES, CHIP, 2.05MEG Ω , \pm 1%, 1/16W, 0402 | VISHAY, CRCW04022M05FKED |
| 12 | 1 | U1 | Micropower USB Power Manager with Two Step-Down Regulators | LINEAR TECH., LTC3554EPD |
| ADDITIONAL DEMO BOARD CIRCUIT COMPONENTS | | | | |
| 1 | 1 | C1 | CAP, CHIP, X5R, 10 μ F, \pm 10%, 6.3V, 0603 | TDK, C1608X5R0J106M |
| 2 | 1 | C7 | CAP, CHIP, X5R, 100 μ F, \pm 20%, 6.3V, 1206 | MURATA, GRM31CR60J107ME39L |
| 3 | 1 | D1 | DIODE, Dual Schottky, 30V, 200mA, SOT23 | DIODES INC., BAT54C |
| 4 | 1 | D2 | LED, GREEN, 0603 | LITE-ON, LTST-C190KGKT |
| 5 | 4 | R1, R21, R22, R23 | RES, CHIP, 1 Ω , \pm 5%, 1/16W, 0402 | VISHAY, CRCW04021R00JNED |
| 6 | 3 | R2, R20, R25 | RES, CHIP, 100k Ω , \pm 5%, 1/16W, 0402 | VISHAY, CRCW0402100KJNED |
| 7 | 2 | R4, R5 | RES, CHIP, 10k Ω , \pm 5%, 1/16W, 0402 | VISHAY, CRCW040210KJNED |
| 8 | 2 | R6, R7 | RES, CHIP, 510k Ω , \pm 5%, 1/16W, 0402 | VISHAY, CRCW0402510KJNED |
| 9 | 0 | R8-OPT, R10-OPT | RES, CHIP, 1MEG Ω , \pm 5%, 1/16W, 0402 | VISHAY, CRCW04021M00JNED |
| 10 | 2 | R16, R19 | RES, CHIP, 20 Ω , \pm 5%, 1/16W, 0402 | VISHAY, CRCW040220R0JNED |
| 11 | 1 | R24 | RES, CHIP, 1k Ω , \pm 5%, 1/16W, 0402 | VISHAY, CRCW04021K00JNED |
| HARDWARE FOR DEMO BOARD ONLY: | | | | |
| 1 | 10 | E1, E2, E8, E9, E10, E11, E13, E14, E16, E17 | TURRET, 0.09" | MILLMAX, 2501-2 |
| 2 | 7 | E3, E4, E5, E6, E7, E12, E15 | TURRET, 0.061" | MILLMAX, 2308-2 |
| 3 | 1 | J1 | CONN, USB Mini-B | TYCO, 1734035-2 |
| 4 | 0 | J2-OPT | CONN, 3 Pin Polarized | HIROSE, DF3-3P-2DSA |
| 5 | 7 | JP1, JP2, JP3, JP4, JP5, JP6, JP7 | HEADER, 3 Pin, 2mm | SAMTEC, TMM-103-02-L-S |
| 6 | 7 | JP1, JP2, JP3, JP4, JP5, JP6, JP7 | SHUNT, 2mm | SAMTEC, 2SN-BK-G |
| 7 | 2 | PB1, PB2 | SWITCH, N.O. Momentary, 3.5mmx6mm SMT | PANASONIC, EVQPPFA25 |
| 8 | 4 | | STAND-OFF, NYLON, 0.375" | KEYSTONE, 8832 |
| 9 | 1 | | FAB, PRINTED CIRCUIT BOARD | DEMO CIRCUIT 1468-1 |
| 10 | 1 | | STENCIL-TOP | STENCIL #1468-1-TOP |
| 11 | 1 | | STENCIL-BOTTOM | STENCIL #1468-1-BOTTOM |

Figure 4. Bill of Materials