

Features

- Antenna Driver Stage with Adjustable Antenna Peak Current for up to 1.5A
- Frequency Tuning Range from 100 kHz to 150 kHz
- Automatic Antenna Peak Current Regulation
- Self-tuning Oscillator for Antenna Resonant Frequency Adaption
- Capable of Driving a High-Q Antenna
- Integrated 5V Regulator for External Load up to 10 mA
- Bi-directional Single Wire Interface for Microcontroller or ECU
- LF Baud Rates up to 4 kbaud and Amplitude Shift Keying (ASK) Modulation
- Low Power Standby Mode < 50 μ A
- Antenna Driver Diagnosis: Peak Current, Antenna Frequency and Battery Voltage Monitoring
- Power Supply Range 8V to 24V Direct Battery Input
- Load Dump Protection
- Operation at Temperature -40°C to $+105^{\circ}\text{C}$
- EMI and ESD According to Automotive Requirements
- Highly Integrated, Fewer External Components Required
- Overtemperature Protection

Applications

- Tire Pressure Measurement (TPM)

Benefits

- Self Tuning Capability to Antenna Resonance Frequency
- Adjustable Antenna Peak Current Value
- Highest Integration Level for Embedded Automotive Systems

Electrostatic sensitive device.

Observe precautions for handling.



1. Description

The ATA5275 is an integrated 1.5A peak current BCDMOS antenna driver IC dedicated as a 125 kHz wake-up channel transmitter for TPM applications.

It includes the full functionality to generate a magnetic LF field in conjunction with an antenna coil to transmit data and power to a receiver. The transmission can be controlled via a one wire I/O-interface by an external unit.

The smart power IC is delivered in a QFN20 power package with heat slug.



**125 kHz
Transmitter IC
for TPM**

ATA5275



2. General Description

The ATA5275 is a 125-kHz transmitter IC. It is dedicated to driving 125 kHz LC antenna tanks, specifically for the wake-up channel in Tire Pressure Measurement (TPM) applications.

It includes a control logic with VCO which generates the 125 kHz signal for the output driver stage. A phase lock circuit regulates the driver output frequency on the antenna resonance frequency, achieving a maximum field strength on the antenna. The driver duty cycle is regulated and stabilizes the antenna current for a wide supply voltage range.

The IC can be controlled by a microcontroller or ECU via the one wire bi-directional interface. It is used for the data transmission and to indicate errors. For the data transmission ASK modulation is used. The antenna signal is modulated by the DIO interface line.

The IC has a build in diagnosis function and detects detuning and broken or short wire of the antenna circuitry. If a failure is detected the IC indicates it by an error signal via the DIO line.

The integrated 5V regulator can be used externally for a load up to 10 mA.

Figure 2-1. Block Diagram

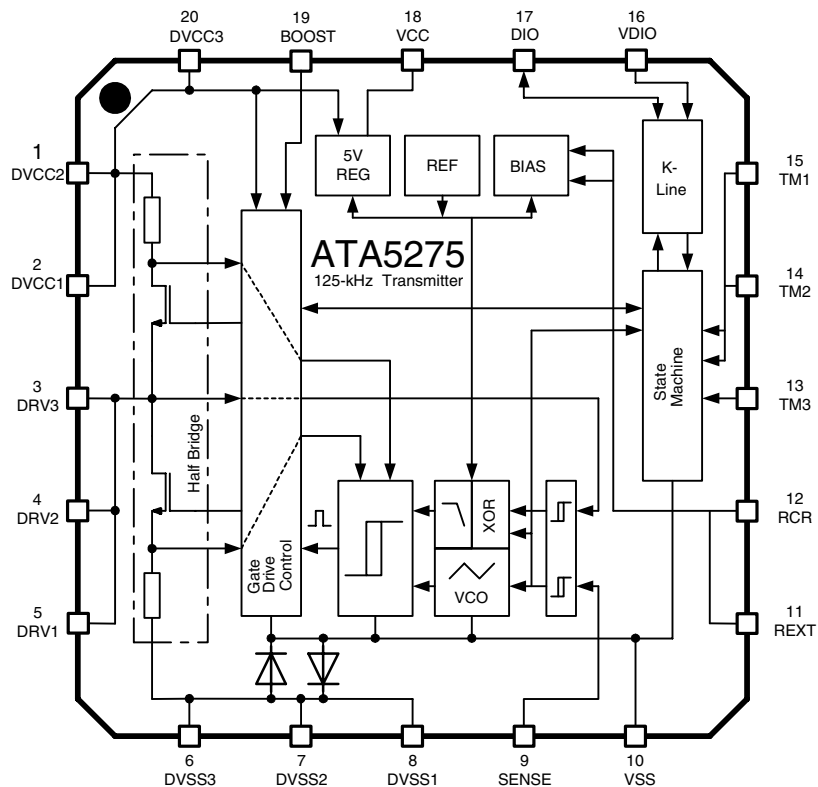

3. Pin Configuration

Figure 3-1. Pinning QFN20

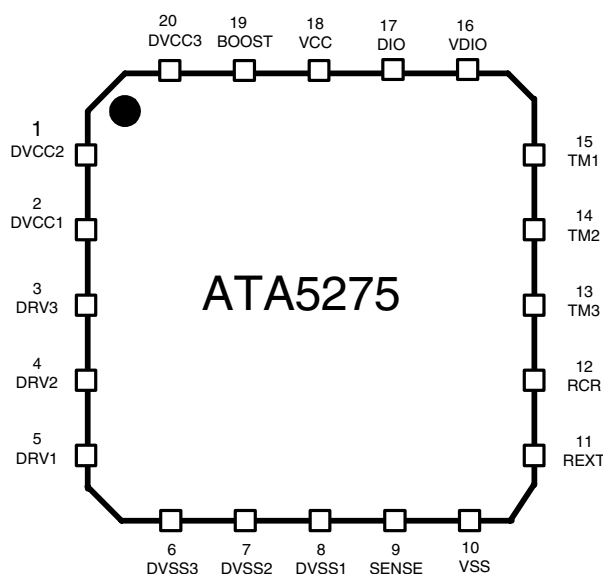

Table 3-1. Pin Description

Pin ⁽¹⁾	Symbol	Function
1	DVCC2	Battery supply input
2	DVCC1	Battery supply input
3	DRV3	Antenna driver stage output
4	DRV2	Antenna driver stage output
5	DRV1	Antenna driver stage output
6	DVSS3	Power supply ground
7	DVSS2	Power supply ground
8	DVSS1	Power supply ground
9	SENSE	Current zero crossing sense input
10	VSS	Analog and digital ground
11	REXT	External reference current input
12	RCR	External reference for antenna peak current
13	TM3	For test purposes only
14	TM2	For test purposes only
15	TM1	For test purposes only
16	VDIO	DIO line interface voltage selection
17	DIO	One-wire serial interface line
18	VCC	5V supply output (for external storage capacitor only)
19	BOOST	External bootstrap cap
20	DVCC3	Battery supply input

Note: 1. Pin numbers valid for all revisions of the ATA5275

4. Functional Description

4.1 Operation Modes

There are two different operation modes for the ATA5275:

- Standby mode
- Transmission mode

4.2 Standby Mode and Wake-up

After power-on-reset, the ATA5275 is in standby mode. For minimum power consumption, only the internal 5V supply and the DIO line interface are active. The IC can be activated by the external control unit via the serial interface. The DIO line is called logic high if it is pulled up to the VDIO voltage level. The DIO line is called logic low if it is pulled down to the VSS voltage level. A low signal at the DIO line wakes-up the IC.

The circuit enters the standby mode if either of these three conditions are fulfilled:

1. After power-on-reset and the DIO is high (see [Figure 4-1](#))
2. After a time out of $T_{OUTL}^{(1)}$ during which DIO is permanently low (see [Figure 4-3 on page 5](#))
3. After a time out of $T_{OUTH}^{(2)}$ during which DIO is permanently high and an acknowledge time $T_{ACK}/T_{ERR}^{(1)}$ (see [Figure 4-2](#))

Notes: 1. Time does not depend on the antenna resonance frequency.
2. Time depends on the antenna resonance frequency.

Figure 4-1. STBY After POR

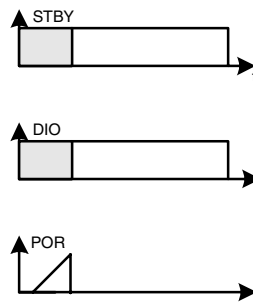

Figure 4-2. STBY After DIO = H

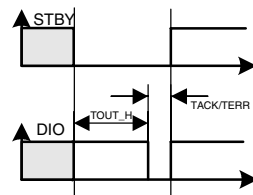
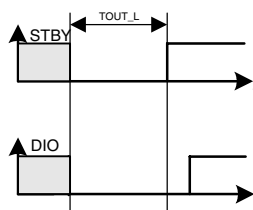

Figure 4-3. STBY After DIO = L



4.3 Transmission Mode

4.3.1 ASK Modulation

For the transmission of a wake-up signal or data to a receiver, the ATA5275 generates an antenna resonance synchronized signal at the antenna driver output (DRV pin). A connected LC antenna radiates a magnetic field. For the data transmission the field can be 100% amplitude modulated by the DIO interface input. If a low level signal is applied at the DIO pin, the driver generates a square wave signal DRV for the antenna. If a high level signal is applied at the DIO pin the driver is stopped and switched to ground. In this way ASK modulated data can be transmitted (see Figure 4-4).

Figure 4-4. Data Transmission

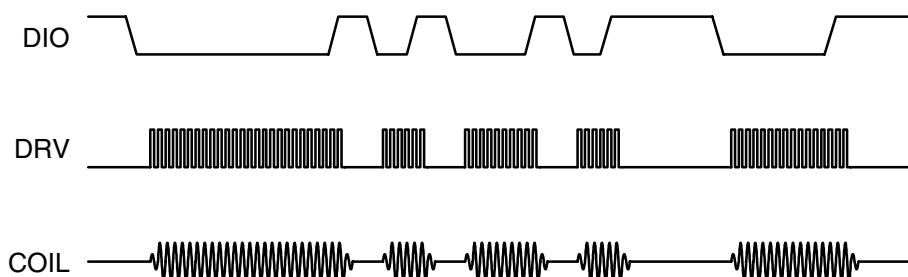

4.3.2 Anti-bouncing Filter in Transmission Mode

The DIO input signal is delayed for an anti-bouncing time.

The driver is switched on after a delay time of T_{DL} (typically 64 μ s) if the DIO is pulled to a low level continuously. The driver is switched-off after a delay time of T_{DH} if the DIO is pulled to high level.

The T_{DH} time depends on the antenna resonance frequency, suppressing short disturbance pulses from the DIO Line.

Figure 4-5. Anti-bouncing

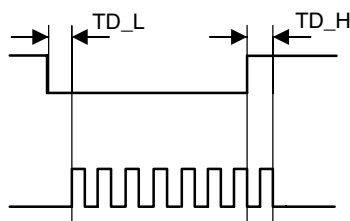

4.3.3 Time Out and Time Out Reset

The IC has a time out supervisor for the interface line to avoid unintended continuous transmission in case of line errors. The time out timer runs if the DIO pin is pulled to a low level. If the DIO pin is permanently low for more than the time T_{OUTL} the driver is switched off and the IC enters the standby mode. This avoids the discharging of the supply battery if the DIO line has a failure like a body contact or another permanent low level failure. The time T_{OUTL} depends on the antenna resonance frequency.

Figure 4-6. Time Out and Time Out Reset Protocol

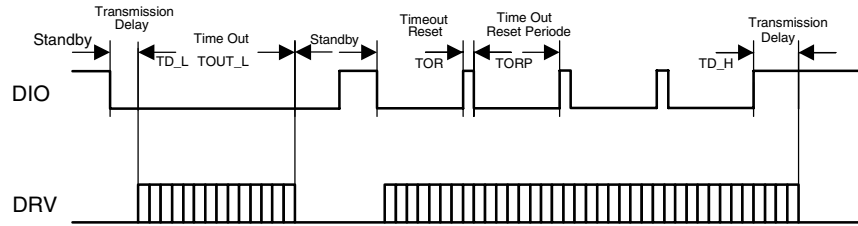

For continuous transmission periods the internal time out timer must be reset within the time out reset period T_{ORP} with a short high pulse of length T_{OR} at DIO. Any transmission time periods can be made by cyclical resetting of the time out timer (see [Figure 4-6](#)). The time T_{ORP} and T_{OR} depends on the antenna resonance frequency.

4.3.4 Transmission Acknowledge and Error Signal

If no failure is detected during a transmission sequence the IC acknowledges the transmission by pulling the DIO line to low level for time T_{ACK} (typically 256 μ s). The acknowledge signal is generated at the end of a transmission sequence if the DIO line was high for the time T_{OUTH} (typically 16 ms).

There are two types of error detection (see section [“Diagnosis and Protection”](#) on page 8):

- Immediate switch-off of the driver stage
- The failure is indicated through the DIO line based on transmission acknowledge and Error signal

At the end of transmission the IC indicates the failure by an error signal by pulling the DIO line to a low level for time T_{ERR} (typically 128 μ s) instead of T_{ACK} .

With the acknowledge and the error signal a connected microcontroller is able to recognize failures of the IC or the antenna module as well as DIO line failures like a broken wire or a short circuit.

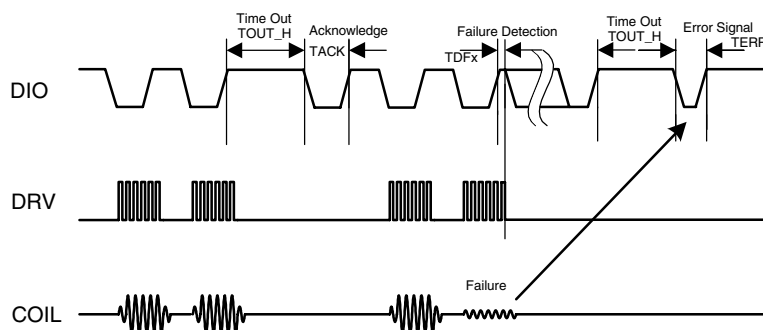
Figure 4-7. Transmission Acknowledge and Error Signal

The various failure types are monitored during transmission in time TFDx (see section “[Diagnosis and Protection](#)” on page 8). The time TFDx depends on the antenna resonance frequency.

4.4 Internal Voltage Regulator and POR

The IC contains a 5-V regulator. It is used for the supply voltage V_{CC} of the logic circuits and the low voltage analog circuits. Additionally, the V_{CC} can be used externally for loads up to 10 mA. The stabilized voltage is available at pin VCC and must be buffered with an external capacitor.

4.4.1 Reset

After power on or after a voltage breakdown the power-on-reset circuit of the IC generates a reset pulse which sets the logic circuit to a defined initial state. A RESET is generated if the VCC is below the reset threshold voltage V_{POR} and after power on.

4.4.2 DIO Interface

The interface can be operated either as a 5-V microcontroller interface or as automotive K-line interface with the car battery voltage. In which mode it operates must be selected with the VDIO pin. If it is connected to 5V the DIO pin operates as microcontroller interface and if it is connected with the battery voltage it operates as automotive interface according to the K-line specification.

4.5 Oscillator and Carrier Frequency Generation

A Voltage Controlled Oscillator (VCO) is used to clock the interface logic and the gate driver logic. The antenna driver output signal DRV is derived from this clock. The VCO operates in two modes: the self-oscillation mode with clock CLK_{SO} and the resonance tracking mode with clock CLK_{RT} .

4.5.1 Self-oscillating Mode

If the antenna half-bridge is not activated the VCO is in self-oscillating mode. It runs at a center frequency CLK_{SO} of typically 125 kHz with an accuracy of $\pm 8\%$. For that purpose, an external reference resistor has to be applied to pin REXT. The resistor at pin REXT determines the VCO frequency proportionally. The recommended value is 100 k Ω achieving 125 kHz oscillator frequency.

4.5.2 Resonance Tracking Mode

In case the antenna half-bridge is activated the VCO is tracked by the antenna current by means of its zero crossing detection. The VCO runs at the antenna resonance frequency stationary. The clock CLK_{RT} deviates $\pm 1.4\%$ from the antenna resonance frequency, depending on the antenna quality and resonance frequency (see section [“Application Hints” on page 14](#)). For that purpose, an antenna current shunt resistor has to be applied to the SENSE pin. The shunt resistance is used internally for the zero crossing detection of the antenna current only.

By this feature the antenna operates with the maximum voltage, current and field strength. It is recommended specially for systems with high antenna Q-factors and low LC tolerances.

4.6 Coil Driver Output and Antenna Peak Current Control

The driver circuit consists on a DMOS half-bridge designed for 1.5A peak current with low on-resistance $R_{DS(on)}$. It is short-circuit and overtemperature protected (see section [“Diagnosis and Protection” on page 8](#)). The half-bridge is switched on by a low level signal at DIO and generates a square wave voltage for the antenna RLC circuitry.

A very useful function of the driver stage is the build-in antenna current control loop. The IC senses the current through the antenna internally and controls the peak value $I_{A_{PEAK}}$ by controlling the duty cycle DC_{DRV} of the driver output.

So the antenna can be designed for maximum antenna current with the typical or even the minimum supply voltage. For higher supply voltages the current is controlled by reducing the driver duty cycle. The reference value for the antenna current $I_{A_{PEAK}}$ can be adjusted externally with a resistor R_{CR} at the RCR pin.

$$I_{A_{PEAK}} = 750 \text{ mA} \times \frac{50 \text{ k}\Omega}{R_{CR}}$$

Note: Applying the formula above, the right driver current for the antenna has to be adjusted for the worst supply voltage case. The IC operates from 14% up to 86% duty cycle for that case and reduces the duty cycle for higher voltages (for the definition of the duty cycle DC_{DRV} , see [“Application Hints” on page 14](#)).

This feature allows the user to operate the IC in a wide field of operational voltage field and protects the driver stage and the antenna from antenna overcurrent.

The driver out square wave starts with a duty cycle of 50%. After three or four cycles the duty cycle can reach its maximum. As far as the peak current will stay smaller than $I_{A_{peak}}$ this duty cycle maximum is really 100%. If during the ramp up of the antenna current the envelope of the peak current will be greater than $I_{A_{peak}} + 20\%$ a pulse skipping function will suppress the next driver output pulse to minimize the antenna current overshoot.

4.7 Diagnosis and Protection

The IC supervises several parameters of IC operation for transmission diagnosis and circuit protection.

In any case of circuit protection mode or error detection the IC indicates this states according to the transmission protocol via the DIO line (see section [“Transmission Acknowledge and Error Signal” on page 6](#)).

4.7.1 Circuit Protection Cases

The circuit protection is activated in normal mode, i.e., if the antenna circuit is driven to the oscillation with its own frequency. It is switched off in standby mode. Between the end of the transmission and the acknowledge signal the low side driver is switched on. In case a protection switch-off occurs the half-bridge is set in tri-state mode.

For all cases, there is a filter implemented to debounce half-bridge switch-off for a time of T_{DEB} (typically 20 μ s). This debounce filter is activated in case the half-bridge is activated.

These are the following circuit protection cases:

1. Load dump protection: In case the voltage at DVCC exceeds a voltage V_{BAT_LD} (typically 31V).
2. Overtemperature protection: In case the junction temperature exceeds a value of TSD (typically 165°C).
- 3.

4.7.2 Error Diagnosis

During the transmission the diagnosis function of the IC supervises the antenna current and frequency and the half-driver bridge supply voltage. If any error is detected at the end of the transmission cycle the error indication is set (as in circuit protection case).

There are the following diagnosis cases:

1. Under-voltage detection: Monitors if DVCC is below V_{BAT_UV} (typically 6.5V).
2. Antenna frequency error: Diagnosis if the oscillation frequency during transmission is outside the typical tracking range 90 kHz to 160 kHz.
3. Antenna peak current error: Diagnosis if the peak current is greater than the adjusted $I_{A_PEAK} + 15\%$ typically.

5. Absolute Maximum Ratings

Stresses beyond those listed under “Absolute Maximum Ratings” may cause permanent damage to the device. This is a stress rating only and functional operation of the device at these or any other conditions beyond those indicated in the operational sections of this specification is not implied. Exposure to absolute maximum rating conditions for extended periods may affect device reliability.

Parameters	Symbol	Min.	Max.	Unit
Ground	VSS	0	0	V
Power ground	DVSS1,2,3	-0.3	+0.3	V
Reverse protected battery voltage	DVCC1,2,3	-0.3	+44	V
Half-bridge driver output	DRV1,2,3	-0.3	DVCC + 0.3	V
Bootstrap	BOOST	-0.3	DVCC + 6 ⁽²⁾	V
5-V regulator output	VCC	-0.3	+7	V
Analog reference input	REXT	-0.3	VCC + 0.3	V
	RCR	-0.3	VCC + 0.3	V
Digital test mode	TM1,2,3	-0.3	VCC + 0.3	V
DIO interface supply	VDIO	-0.3	DVCC + 0.3	V
DIO interface	DIO	-0.3	DVCC + 0.3	V
Zero crossing analog input	SENSE	-2	DVCC + 0.3	V
Electromagnetic Interference	EMI		250	V/M
Minimum ESD protection (100 pF through 1.5 kΩ)			1 (on PCB)	kV
Power dissipation	P _{tot}		2 ⁽¹⁾	W
Junction temperature	ϑ _j		150	°C
Storage temperature	ϑ _{STORE}	-55	+125	°C
Ambient temperature range under bias	ϑ _{ambient}	-40	+105	°C
Soldering temperature (10s)	ϑ _{SOLDERING}		260 +0/-5	°C

Notes: 1. May be limited by external thermal resistance.

2. If the low side driver is switched on, it is not allowed to connect a voltage source to pin BOOST.

6. Thermal Resistance

Parameters	Symbol	Value	Unit
Thermal resistance, junction ambient	R _{thJA}	35	K/W

7. Operating Range

The operating conditions define the limits for functional operation and parametric characteristics of the device. Functionality outside these limits is not implied if not otherwise stated explicitly.

Parameters	Symbol	Value	Unit
Operating supply voltage	V _{VBAT1}	8 to 24	V
Operating temperature range	ϑ _{amb}	-40 to +105	°C

8. Noise and Surge Immunity

Parameter	Test Conditions	Value
Conducted interferences	ISO 7637-1	Level 4 ⁽¹⁾

Note: 1. Test pulse 5: $V_{smax} = 45V$

9. Electrical Characteristics⁽¹⁾

No.	Parameters	Test Conditions	Pin	Symbol	Min.	Typ.	Max.	Unit	Type*
1	Power Supply								
1.1	Main supply voltage	I(VCC) = 10 mA, including load and line regulation	VCC	V_{CC}	4.7	5.0	5.3	V	A
1.2	Supply current	without antenna load	DVCC	I_{SUPP}	2	10	20	mA	A
1.3	Standby current	Pin DVCC = 13.5V, $T_{amb} = 90^{\circ}C$	DVCC	I_{STBY}	20	35	60	μA	B
1.4	Power-on-reset threshold voltage		VCC	V_{POR}	3.5	4	4.5	V	A
1.5	Load dump protection voltage		DVCC	$VBAT_{LD}$	29	31	35	V	A
1.6	Under voltage detection		DVCC	$VBAT_{UV}$	6.0	6.5	7.0	V	A
1.7	Thermal shut down			TSD	150	165	180	$^{\circ}C$	B
1.8	Protection debounce filter			T_{DEB}	10	15	25	μs	A
2	Half-bridge Driver Stage								
2.1	Coil driver resistance low side driver		DRV, DVSS	RDS_{ONL}		0.3	0.7	Ω	A
2.2	Coil driver resistance high side driver		DVCC, DRV	RDS_{ONH}		0.3	0.7	Ω	A
2.3	Driver output rise time	10% to 90% slope time, 0% = DVSS, 100% = DVCC DVCC = 12V (smooth edges)	DRV	$T_{DRV,RISE}$	50	100	150	ns	D
2.4	Driver output fall time	10% to 90% slope time, 0% = DVSS, 100% = DVCC DVCC = 12V (smooth edges)	DRV	$T_{DRV,FALL}$	50	100	150	ns	D

*) Type means: A = 100% tested, B = 100% correlation tested, C = Characterized on samples, D = Design parameter

Notes: 1. $8V < V(DVCC) < 24V$; $-40^{\circ}C < \vartheta_{amb} < 105^{\circ}C$, unless otherwise specified; all values refer to GND

2. Definition of DC_{DRV} see "Application Hints" on page 14

3. $I_{VDIO, stby} = 7.5 \mu A$ at $T_{amb} = 90^{\circ}C$

9. Electrical Characteristics⁽¹⁾ (Continued)

No.	Parameters	Test Conditions	Pin	Symbol	Min.	Typ.	Max.	Unit	Type*
3	Antenna Peak Current Control								
3.1	Duty cycle control range		DRV	$DC_{DRV}^{(2)}$	15		85	%	B
3.2	Peak current control reference		RCR	V_{RCR}	1.15	1.215	1.28	V	A
3.3	Peak current control accuracy	$R_{CR} = 25\text{ k}\Omega$		$I_{A_{peak}}$	1.0	1.3	1.8	A	B
3.4	Antenna peak under current threshold	0% NOM value = $I_{A_{acc}}$ $R_{CR} = 25\text{ k}\Omega$		$I_{A_{UC}}$	-30	-20	-10	%	A
3.5	Antenna peak overcurrent threshold	0% NOM value = $I_{A_{acc}}$ $R_{CR} = 25\text{ k}\Omega$		$I_{A_{OV}}$	30	20	10	%	A
4	Oscillator and Phase Control								
4.1	VCO initial frequency	Self oscillating mode = half-bridge not activated		CLK_{SO}	115	125	135	kHz	A
4.2	VCO frequency tracking range	Tracking frequency mode = half-bridge activated		CLK_{TR}	80		200	kHz	B
4.3	Phase shift between voltage at DRV and zero crossing of current through SENSE	Antenna resonance frequency range = 100 kHz to 150 kHz, antenna quality = 5 to 50	DRV, SENSE	ϕ_A	-120	0	+120	ns	B
4.4	Phase control set-up time	$-240\text{ ns} \leq \phi_A \leq +240\text{ ns}$	DRV, SENSE	T_{setup}			160	μs	D
4.5	High frequency failure threshold		DRV	f_{VCOH}	150	160	200	kHz	A
4.6	Low frequency failure threshold		DRV	f_{VCOL}	80	90	105	kHz	A
5	DIO Interface								
5.1	VDIO leakage current	Pin VDIO = 13.5V, Pin DIO = 13.5V $T_{amb} \leq 27^\circ\text{C}^{(3)}$	VDIO	$I_{VDIO,STBY}$	2	4	5	μA	A
5.2	DIO leakage current	Pin VDIO = 13.5V, Pin DIO = 13.5V $T_{amb} = 90^\circ\text{C}$	DIO	$I_{DIO,LEAK}$	2	4	200	μA	A
5.3	DIO sink current		DIO	$I_{DIO,LIMIT}$	36	44	52	mA	A
5.4	Output low level	$I_{DIO} = 20\text{ mA}$	DIO	$V_{DIO,L}$		1.2	1.5	V	A
5.5	Input low level threshold	100% = DVCC	DIO	$V_{DIO,THL}$	30	45	70	%V (VDIO)	A
5.6	Input high level threshold	100% = DVCC	DIO	$V_{DIO,TLH}$	30	50	70	%V (VDIO)	A

*) Type means: A = 100% tested, B = 100% correlation tested, C = Characterized on samples, D = Design parameter

Notes: 1. $8\text{V} < V(\text{DVCC}) < 24\text{V}$; $-40^\circ\text{C} < \vartheta_{amb} < 105^\circ\text{C}$, unless otherwise specified; all values refer to GND

2. Definition of DC_{DRV} see "Application Hints" on page 14

3. $I_{VDIO,STBY} = 7.5\text{ }\mu\text{A}$ at $T_{amb} = 90^\circ\text{C}$

9. Electrical Characteristics⁽¹⁾ (Continued)

No.	Parameters	Test Conditions	Pin	Symbol	Min.	Typ.	Max.	Unit	Type*
6	Transmission Protocol								
6.1	LF data baud rate			Bd _{RF}		1	4	kbit/s	C, D
6.2	Anti-bouncing time for activate half-bridge	DIO = H → L, for f _{VCO} = 125 kHz		T _{DL}		64		μs	B
6.3	Anti-bouncing time for de-activate half-bridge	DIO = L → H, for f _{VCO} = 125 kHz		T _{DH}		64		μs	B
6.4	Acknowledge pulse width			T _{ACK}		256		μs	B
6.5	Error signal pulse width			T _{ERR}		128		μs	B
6.6	Transmission time out de-activated half-bridge			T _{OUTL}		16		ms	B
6.7	Transmission time out activated half-bridge			T _{OUTH}		16		ms	
6.8	Time out reset pulse width			T _{OR}		32		μs	
6.9	Time out reset pulse period			T _{ORP}		15		ms	

*) Type means: A = 100% tested, B = 100% correlation tested, C = Characterized on samples, D = Design parameter

Notes: 1. $8V < V(DVCC) < 24V$; $-40^{\circ}C < \vartheta_{amb} < 105^{\circ}C$, unless otherwise specified; all values refer to GND

2. Definition of DC_{DRV} see "Application Hints" on page 14

3. I_{V_{DIO},stby} = 7.5 μA at T_{amb} = 90°C

10. External Components

The following external components have to be applied to the circuit for functional operation (see Figure 11-1 on page 15).

Component	Pin	Min.	Typ.	Max.	Unit
C1	DVCC		100/50		μF/V
D1 standard diode			1.5/50		A/V
R _{EXT}	REXT		100		kΩ
R _{CR}	RCR ⁽³⁾	25		200	kΩ
C3	VCC		10		μF
C2	BOOST	0.68	1	2	nF
R _{SENSE}	SENSE ⁽¹⁾	0.1 ⁽²⁾	0.5	1	Ω
R _{DIO}	DIO	0.6	1	6	kΩ
L _{ANT} antenna inductance			345/2.5		μH/Ω
R _{ANT} Q-factor adjuster			10		Ω
C _{ANT} resonant-frequency adjuster			4.7/400		nF/V

Notes: 1. Sensitivity at input SENSE is proportional to resistor R_s times antenna peak current.

2. For antenna peak value 1.5A.

3. Recommended range: R_{CR} = 25 to 100 kΩ

11. Application Hints

A typical application of ATA5275 is shown in [Figure 11-1 on page 15](#). The peak value of the antenna current can be estimated by the formula:

$$\hat{I}_A = \frac{2}{\pi} \times \frac{V_{DVCC}}{R_A} \times \sin\left(\frac{\pi}{2} \times DC_{DRV}\right) \times \cos\phi_A$$

Here R_A denotes the equivalent series resistance of the driver load, i.e., the external coil series resistance in series with the shunt resistance and the internal drain-source-on-resistance of the NDMOS. The duty cycle DC_{DRV} is the ratio of the driver high-side on-time with respect to the half of the oscillation period.

The phase difference ϕ_A is measured as the time difference between the point of mass of V_{DRV} and the peak value of the antenna current.

Figure 11-1. Application Circuit

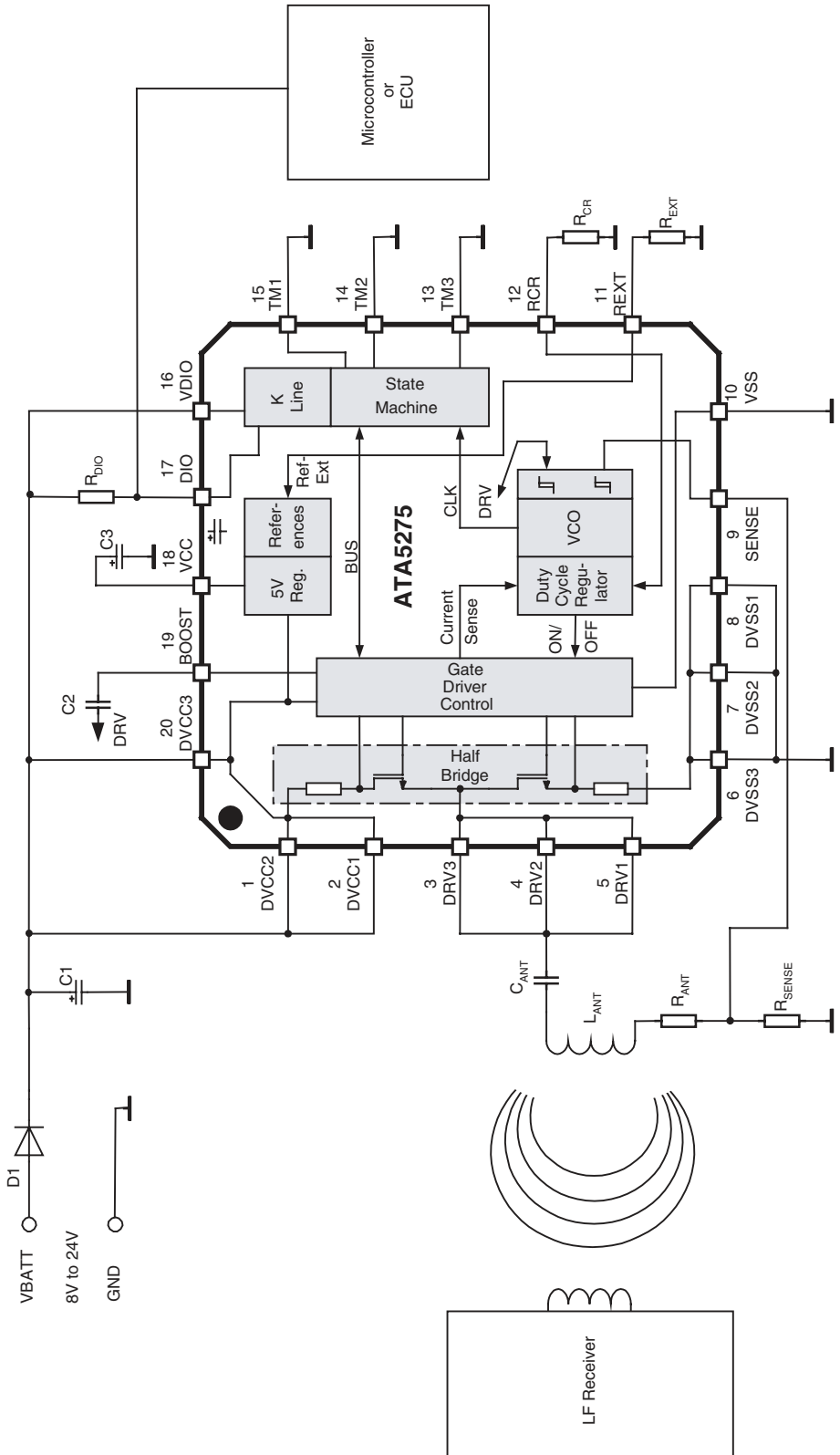

Note: For the typical values of the external components, see table "External Components" on page 13.



12. Ordering Information

Extended Type Number	Package	Remarks	Minimum Order Quantity
ATA5275-PGQI	QFN20, 5 mm × 5 mm	Pb-free, Taped and reeled	6,000
ATA5275-PGPI	QFN20, 5 mm × 5 mm	Pb-free, Taped and reeled	1,500

13. Package Information

Package: QFN 20 - 5 x 5
 Exposed pad 2.7 x 2.7
 (acc. JEDEC OUTLINE No. MO-220)

Dimensions in mm

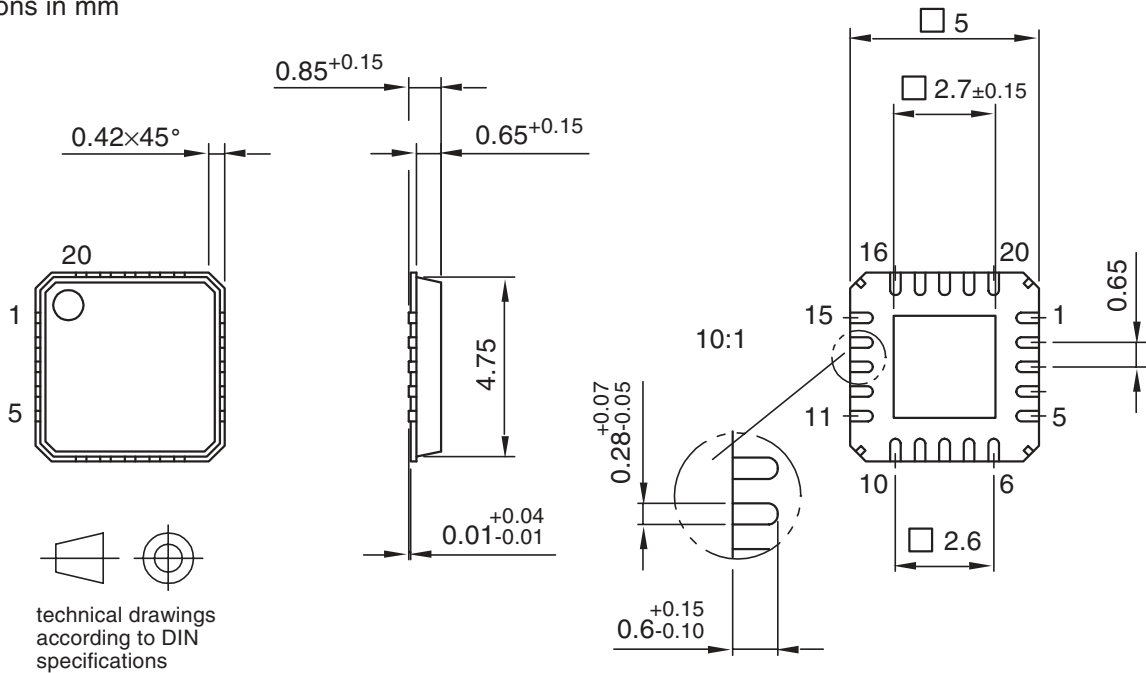

Drawing-No.: 6.543-5069.01-4

Issue: 3; 24.01.03

14. Revision History

Please note that the following page numbers referred to in this section refer to the specific revision mentioned, not to this document.

Revision No.	History
4739I-AUTO-12/05	<ul style="list-style-type: none"> Page 1: Pb-free logo deleted Page 15: Application Circuit changed
4739H-AUTO-11/05	<ul style="list-style-type: none"> Table "Ordering Information" on page 16 changed
4739G-AUTO-09/05	<ul style="list-style-type: none"> Table "Absolute Maximum Ratings" on page 10 changed



Atmel Corporation

2325 Orchard Parkway
San Jose, CA 95131, USA
Tel: 1(408) 441-0311
Fax: 1(408) 487-2600

Regional Headquarters

Europe

Atmel Sarl
Route des Arsenaux 41
Case Postale 80
CH-1705 Fribourg
Switzerland
Tel: (41) 26-426-5555
Fax: (41) 26-426-5500

Asia

Room 1219
Chinachem Golden Plaza
77 Mody Road Tsimshatsui
East Kowloon
Hong Kong
Tel: (852) 2721-9778
Fax: (852) 2722-1369

Japan

9F, Tonetsu Shinkawa Bldg.
1-24-8 Shinkawa
Chuo-ku, Tokyo 104-0033
Japan
Tel: (81) 3-3523-3551
Fax: (81) 3-3523-7581

Atmel Operations

Memory

2325 Orchard Parkway
San Jose, CA 95131, USA
Tel: 1(408) 441-0311
Fax: 1(408) 436-4314

Microcontrollers

2325 Orchard Parkway
San Jose, CA 95131, USA
Tel: 1(408) 441-0311
Fax: 1(408) 436-4314

La Chantrerie
BP 70602
44306 Nantes Cedex 3, France
Tel: (33) 2-40-18-18-18
Fax: (33) 2-40-18-19-60

ASIC/ASSP/Smart Cards

Zone Industrielle
13106 Rousset Cedex, France
Tel: (33) 4-42-53-60-00
Fax: (33) 4-42-53-60-01

1150 East Cheyenne Mtn. Blvd.
Colorado Springs, CO 80906, USA
Tel: 1(719) 576-3300
Fax: 1(719) 540-1759

Scottish Enterprise Technology Park
Maxwell Building
East Kilbride G75 0QR, Scotland
Tel: (44) 1355-803-000
Fax: (44) 1355-242-743

RF/Automotive

Theresienstrasse 2
Postfach 3535
74025 Heilbronn, Germany
Tel: (49) 71-31-67-0
Fax: (49) 71-31-67-2340

1150 East Cheyenne Mtn. Blvd.
Colorado Springs, CO 80906, USA
Tel: 1(719) 576-3300
Fax: 1(719) 540-1759

Biometrics/Imaging/Hi-Rel MPU/ High Speed Converters/RF Datacom

Avenue de Rochepleine
BP 123
38521 Saint-Egreve Cedex, France
Tel: (33) 4-76-58-30-00
Fax: (33) 4-76-58-34-80

Literature Requests

www.atmel.com/literature

Disclaimer: The information in this document is provided in connection with Atmel products. No license, express or implied, by estoppel or otherwise, to any intellectual property right is granted by this document or in connection with the sale of Atmel products. **EXCEPT AS SET FORTH IN ATMEL'S TERMS AND CONDITIONS OF SALE LOCATED ON ATMEL'S WEB SITE, ATMEL ASSUMES NO LIABILITY WHATSOEVER AND DISCLAIMS ANY EXPRESS, IMPLIED OR STATUTORY WARRANTY RELATING TO ITS PRODUCTS INCLUDING, BUT NOT LIMITED TO, THE IMPLIED WARRANTY OF MERCHANTABILITY, FITNESS FOR A PARTICULAR PURPOSE, OR NON-INFRINGEMENT. IN NO EVENT SHALL ATMEL BE LIABLE FOR ANY DIRECT, INDIRECT, CONSEQUENTIAL, PUNITIVE, SPECIAL OR INCIDENTAL DAMAGES (INCLUDING, WITHOUT LIMITATION, DAMAGES FOR LOSS OF PROFITS, BUSINESS INTERRUPTION, OR LOSS OF INFORMATION) ARISING OUT OF THE USE OR INABILITY TO USE THIS DOCUMENT, EVEN IF ATMEL HAS BEEN ADVISED OF THE POSSIBILITY OF SUCH DAMAGES.** Atmel makes no representations or warranties with respect to the accuracy or completeness of the contents of this document and reserves the right to make changes to specifications and product descriptions at any time without notice. Atmel does not make any commitment to update the information contained herein. Unless specifically provided otherwise, Atmel products are not suitable for, and shall not be used in, automotive applications. Atmel's products are not intended, authorized, or warranted for use as components in applications intended to support or sustain life.

© Atmel Corporation 2006. All rights reserved. Atmel®, logo and combinations thereof, Everywhere You Are® and others, are registered trademarks or trademarks of Atmel Corporation or its subsidiaries. Other terms and product names may be trademarks of others.



Printed on recycled paper.