

Medium current, high performance, low voltage PNP transistor

Features

- Very low collector to emitter saturation voltage
- DC current gain, $h_{FE} > 100$
- 3 A continuous collector current
- 40 V breakdown voltage $V_{(BR)CER}$

Applications

- Power management in portable equipment
- Voltage regulation in bias supply circuits
- Switching regulator in battery charger applications
- Heavy load driver

Description

The devices are manufactured in low voltage PNP planar technology by using a "Base Island" layout. The resulting transistor shows exceptional high gain performance coupled with very low saturation voltage. The STX790AG-AP is supplied using halogen-free molding compound.

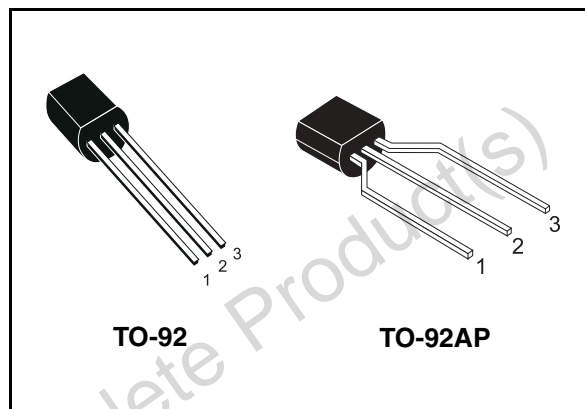

Figure 1. Internal schematic diagram

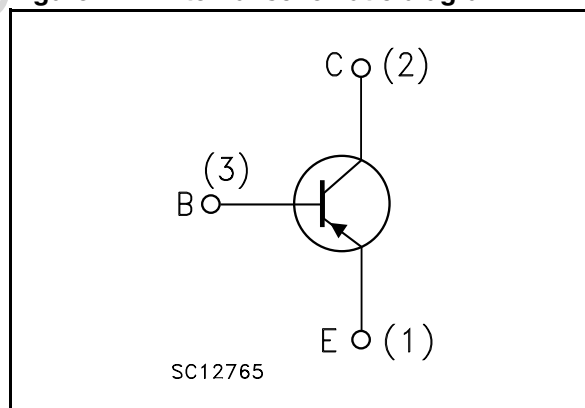

Table 1. Device summary

Order codes	Marking	Packages	Packaging
STX790A	X790A	TO-92	Bulk
STX790A-AP	X790A	TO-92 AP	Ammopack
STX790AG-AP	X790AG	TO-92 AP	Ammopack

1 Electrical ratings

Table 2. Absolute maximum ratings

Symbol	Parameter	Value	Unit
V_{CBO}	Collector-base voltage ($I_E = 0$)	-40	V
V_{CER}	Collector-emitter voltage ($R_{BE} = 47 \Omega$)	-40	V
V_{CEO}	Collector-emitter voltage ($I_B = 0$)	-30	V
V_{EBO}	Emitter-base voltage ($I_C = 0$)	-5	V
I_C	Collector current	-3	A
I_{CM}	Collector peak current ($t_p < 5$ ms)	-6	A
P_{tot}	Total dissipation at $T_{amb} = 25$ °C	0.9	W
T_{stg}	Storage temperature	-65 to 150	°C
T_J	Max. operating junction temperature	150	°C

Table 3. Thermal data

Symbol	Parameter	Value	Unit
$R_{thj-case}$	Thermal resistance junction-case	max 44.6	°C/W
$R_{thj-amb}$	Thermal resistance junction-ambient	max 139	°C/W

2 Electrical characteristics

($T_{\text{case}} = 25\text{ °C}$ unless otherwise specified)

Table 4. Electrical characteristics

Symbol	Parameter	Test conditions	Min.	Typ.	Max.	Unit
I_{CBO}	Collector cut-off current ($I_{\text{E}} = 0$)	$V_{\text{CB}} = -30\text{ V}$ $V_{\text{CB}} = -30\text{ V}; T_{\text{C}} = 100\text{ °C}$			-10 -100	μA μA
I_{EBO}	Emitter cut-off current ($I_{\text{C}} = 0$)	$V_{\text{EB}} = -4\text{ V}$			-10	μA
$V_{(\text{BR})\text{CEO}}^{(1)}$	Collector-emitter breakdown voltage ($I_{\text{B}} = 0$)	$I_{\text{C}} = -10\text{ mA}$	-30			V
$V_{(\text{BR})\text{CER}}^{(1)}$	Collector-emitter breakdown voltage ($R_{\text{BE}} = 47\ \Omega$)	$I_{\text{C}} = -10\text{ mA}$	-40			V
$V_{(\text{BR})\text{CBO}}$	Collector-base breakdown voltage ($I_{\text{E}} = 0$)	$I_{\text{C}} = -100\ \mu\text{A}$	-40			V
$V_{(\text{BR})\text{EBO}}$	Emitter-base breakdown voltage ($I_{\text{C}} = 0$)	$I_{\text{E}} = -100\ \mu\text{A}$	-5			V
$V_{\text{CE}(\text{sat})}^{(1)}$	Collector-emitter saturation voltage	$I_{\text{C}} = -0.5\text{ A}$ $I_{\text{B}} = -5\text{ mA}$ $I_{\text{C}} = -1.2\text{ A}$ $I_{\text{B}} = -20\text{ mA}$ $I_{\text{C}} = -2\text{ A}$ $I_{\text{B}} = -20\text{ mA}$ $I_{\text{C}} = -3\text{ A}$ $I_{\text{B}} = -100\text{ mA}$ $I_{\text{C}} = -3\text{ A}$ $I_{\text{B}} = -100\text{ mA}$ $T_{\text{C}} = 100\text{ °C}$			-0.15 -0.25 -0.5 -0.7 -0.9	V V V V V
$V_{\text{BE}(\text{sat})}^{(1)}$	Base-emitter saturation voltage	$I_{\text{C}} = -1\text{ A}$ $I_{\text{B}} = -10\text{ mA}$		-0.8	-1	V
$V_{\text{BE}(\text{on})}^{(1)}$	Base-emitter on voltage	$I_{\text{C}} = -1\text{ A}$ $V_{\text{CE}} = -2\text{ V}$		-0.8	-1	V
$h_{\text{FE}}^{(1)}$	DC current gain	$I_{\text{C}} = -10\text{ mA}$ $V_{\text{CE}} = -2\text{ V}$ $I_{\text{C}} = -500\text{ mA}$ $V_{\text{CE}} = -2\text{ V}$ $I_{\text{C}} = -1\text{ A}$ $V_{\text{CE}} = -2\text{ V}$ $I_{\text{C}} = -2\text{ A}$ $V_{\text{CE}} = -1\text{ V}$ $I_{\text{C}} = -3\text{ A}$ $V_{\text{CE}} = -1\text{ V}$	100 100 100 100 90	200 200 160 130	400 400	

Table 4. Electrical characteristics (continued)

Symbol	Parameter	Test conditions	Min.	Typ.	Max.	Unit
f_t	Transition frequency	$I_C = -50 \text{ mA}$ $V_{CE} = -5 \text{ V}$ $f = 50 \text{ MHz}$		100		MHz
t_d	Resistive load Delay time	$I_C = -3 \text{ A}$ $V_{CC} = -20 \text{ V}$		180	220	ns
t_r	Rise time	$I_{B1} = -I_{B2} = -60 \text{ mA}$		160	210	ns
t_s	Storage time	see Figure 8		250	300	ns
t_f	Fall time			80	100	ns

1. Pulse duration = 300 μs , duty cycle $\leq 1.5\%$

2.1 Electrical characteristics (curves)

Figure 2. DC current gain

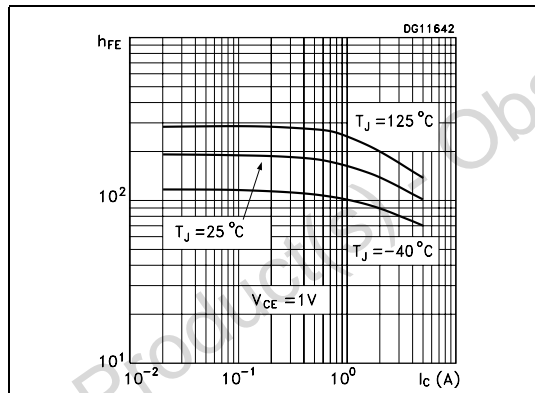

Figure 3. DC current gain

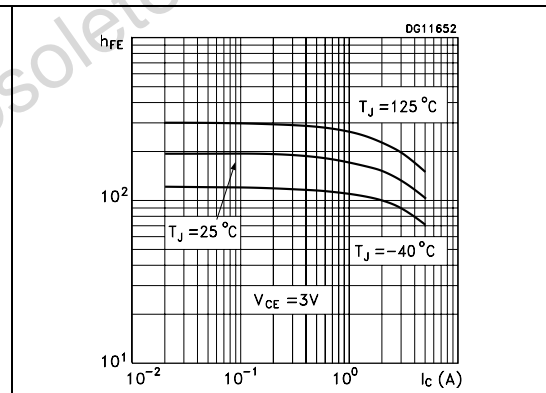

Figure 4. Collector-emitter saturation voltage

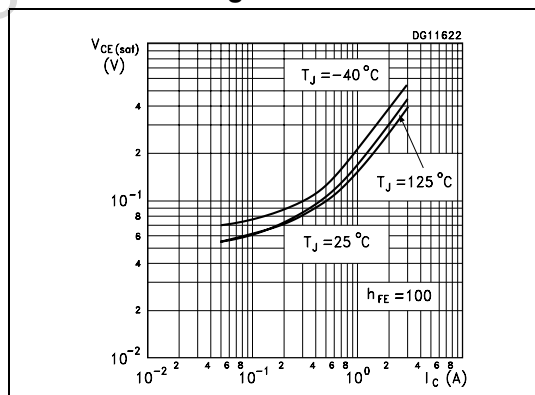

Figure 5. Base-emitter saturation voltage

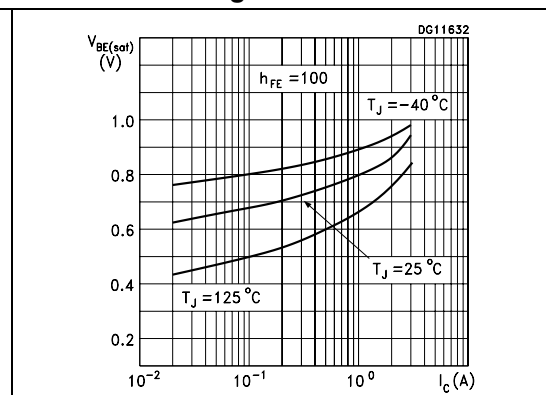
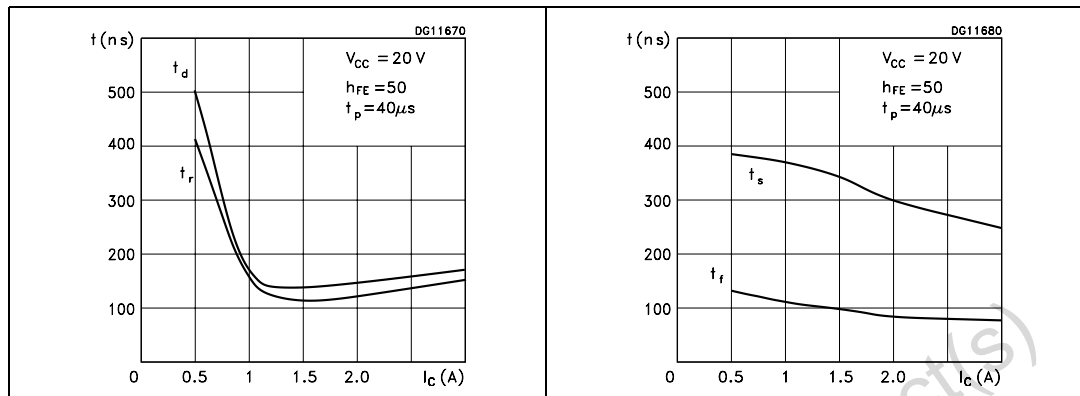
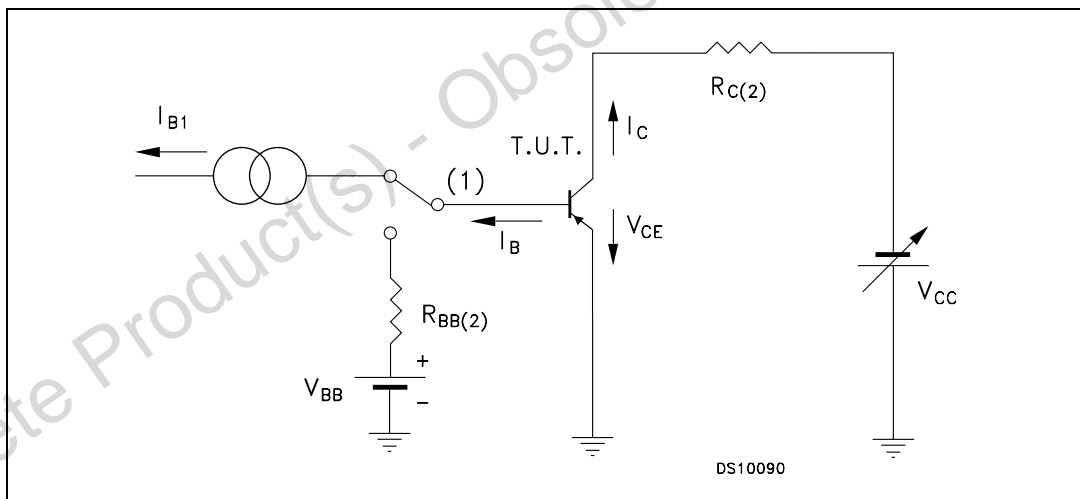

Figure 6. Switching time resistive load Figure 7. Switching time resistive load



2.2 Test circuit

Figure 8. Resistive load switching test circuit



1. Fast electronic switch
2. Non-inductive resistor

3 Package mechanical data

In order to meet environmental requirements, ST offers these devices in different grades of ECOPACK® packages, depending on their level of environmental compliance. ECOPACK® specifications, grade definitions and product status are available at: www.st.com. ECOPACK® is an ST trademark.

Obsolete Product(s) - Obsolete Product(s)

TO-92 bulk shipment mechanical data

DIM.	mm.		
	MIN.	TYP	MAX.
A	4.32		4.95
b	0.36		0.51
D	4.45		4.95
E	3.30		3.94
e	2.41		2.67
e1	1.14		1.40
L	12.70		15.49
R	2.16		2.41
S1	0.92		1.52
W	0.41		0.56
V		5°	

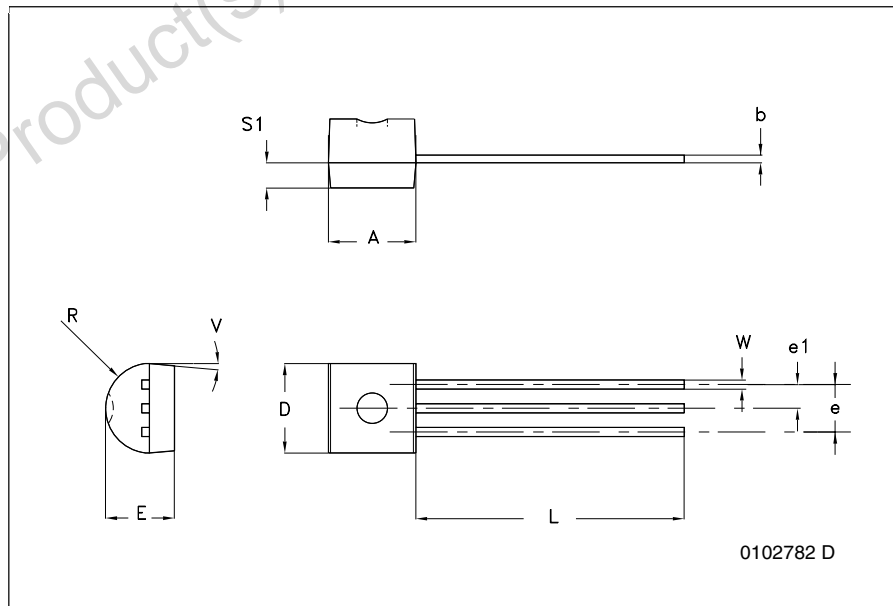

TO-92 ammpack shipment (suffix"-AP") mechanical data

Dim.	mm		
	Min	Typ	Max
A1			4.80
T			3.80
T1			1.60
T2			2.30
d			0.48
P0	12.50	12.70	12.90
P2	5.65	6.35	7.05
F1,F2	2.44	2.54	2.94
F3	4.98	5.08	5.48
delta H	-2.00		2.00
W	17.50	18.00	19.00
W0	5.70	6.00	6.30
W1	8.50	9.00	9.25
W2			0.50
H	18.50		20.50
H3	0.5	1	1.5
H0	15.50	16.00	16.50
H1			25.00
D0	3.80	4.00	4.20
t			0.90
L			11.00
l1	3.00		
delta P	-1.00		1.00

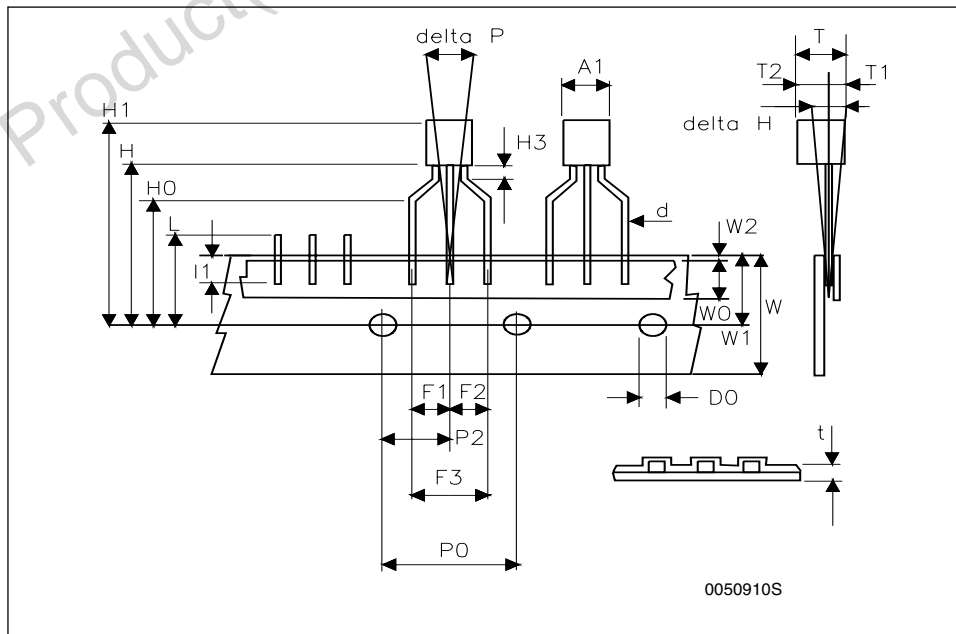

4 Revision history

Table 5. Document revision history

Date	Revision	Changes
24-Mar-2003	1	Initial release.
29-Mar-2006	2	New template.
25-Jun-2008	3	Updated TO-92 mechanical data.
28-Apr-2009	4	Added new order code STX790AG-AP Table 1 on page 1.

Obsolete Product(s) - Obsolete Product(s)

Please Read Carefully:

Information in this document is provided solely in connection with ST products. STMicroelectronics NV and its subsidiaries ("ST") reserve the right to make changes, corrections, modifications or improvements, to this document, and the products and services described herein at any time, without notice.

All ST products are sold pursuant to ST's terms and conditions of sale.

Purchasers are solely responsible for the choice, selection and use of the ST products and services described herein, and ST assumes no liability whatsoever relating to the choice, selection or use of the ST products and services described herein.

No license, express or implied, by estoppel or otherwise, to any intellectual property rights is granted under this document. If any part of this document refers to any third party products or services it shall not be deemed a license grant by ST for the use of such third party products or services, or any intellectual property contained therein or considered as a warranty covering the use in any manner whatsoever of such third party products or services or any intellectual property contained therein.

UNLESS OTHERWISE SET FORTH IN ST'S TERMS AND CONDITIONS OF SALE ST DISCLAIMS ANY EXPRESS OR IMPLIED WARRANTY WITH RESPECT TO THE USE AND/OR SALE OF ST PRODUCTS INCLUDING WITHOUT LIMITATION IMPLIED WARRANTIES OF MERCHANTABILITY, FITNESS FOR A PARTICULAR PURPOSE (AND THEIR EQUIVALENTS UNDER THE LAWS OF ANY JURISDICTION), OR INFRINGEMENT OF ANY PATENT, COPYRIGHT OR OTHER INTELLECTUAL PROPERTY RIGHT.

UNLESS EXPRESSLY APPROVED IN WRITING BY AN AUTHORIZED ST REPRESENTATIVE, ST PRODUCTS ARE NOT RECOMMENDED, AUTHORIZED OR WARRANTED FOR USE IN MILITARY, AIR CRAFT, SPACE, LIFE SAVING, OR LIFE SUSTAINING APPLICATIONS, NOR IN PRODUCTS OR SYSTEMS WHERE FAILURE OR MALFUNCTION MAY RESULT IN PERSONAL INJURY, DEATH, OR SEVERE PROPERTY OR ENVIRONMENTAL DAMAGE. ST PRODUCTS WHICH ARE NOT SPECIFIED AS "AUTOMOTIVE GRADE" MAY ONLY BE USED IN AUTOMOTIVE APPLICATIONS AT USER'S OWN RISK.

Resale of ST products with provisions different from the statements and/or technical features set forth in this document shall immediately void any warranty granted by ST for the ST product or service described herein and shall not create or extend in any manner whatsoever, any liability of ST.

ST and the ST logo are trademarks or registered trademarks of ST in various countries.

Information in this document supersedes and replaces all information previously supplied.

The ST logo is a registered trademark of STMicroelectronics. All other names are the property of their respective owners.

© 2009 STMicroelectronics - All rights reserved

STMicroelectronics group of companies

Australia - Belgium - Brazil - Canada - China - Czech Republic - Finland - France - Germany - Hong Kong - India - Israel - Italy - Japan - Malaysia - Malta - Morocco - Philippines - Singapore - Spain - Sweden - Switzerland - United Kingdom - United States of America

www.st.com