

ITEM	QTY	PART NUMBER	PART DESCRIPTION
1	1	C-101	T-1 (3mm) LED Clip
2	1	R-101	T-1 (3mm) LED Ring

REV.	DESCRIPTION	DATE	APPROVED
A	Engineering Release	01/23/07	M. C.
B	Part Description Update	06/03/09	T. Y.
C	Updated Ø.225 and .168" Dimensions	09/30/10	T. Y.
D	Removed Material Code	05/28/16	J. C.

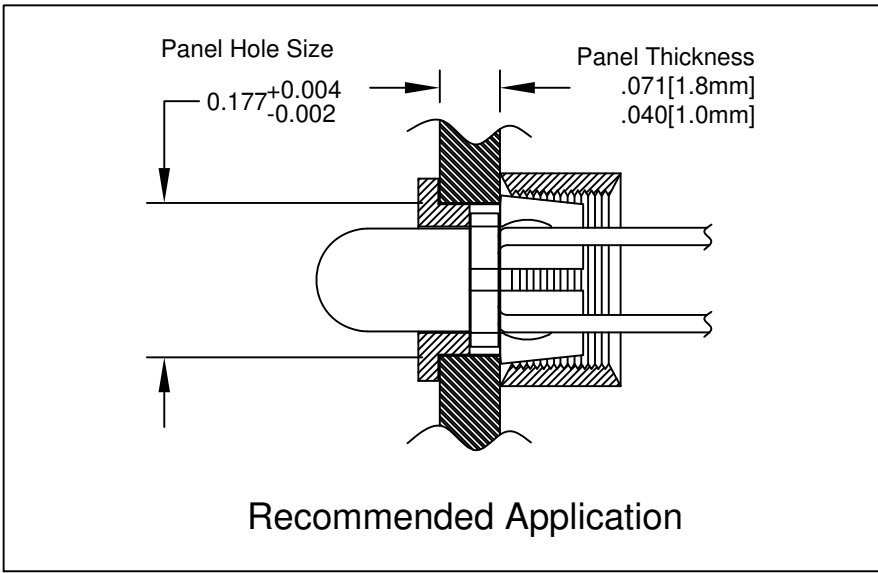
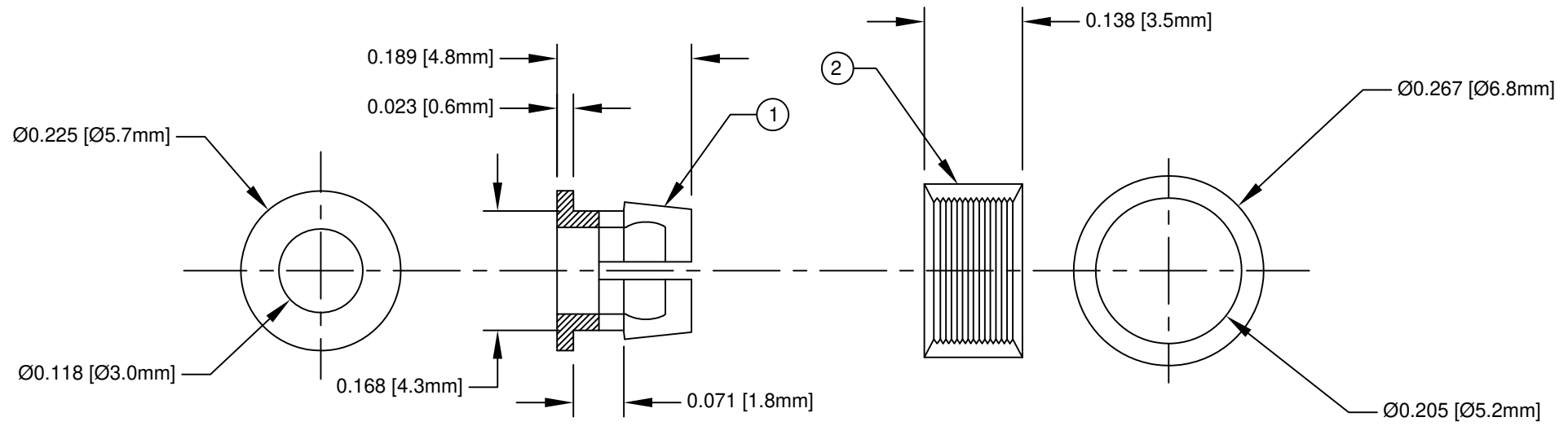

2. MATERIAL: NYLON 6/6, 94V-2, BLACK.

1. GENERAL SPECIFICATIONS: BIVAR MOLDED COMPONENT SPECIFICATION BV00-101.

STANDARD TOLERANCE (UNLESS OTHERWISE SPECIFIED)		BIVAR®	
DECIMALS	ANGULAR	4 THOMAS, IRVINE, CA. 92618	
.X ± .1	X° ± 1°	TEL: (949) 951-8808 FAX: (949) 951-3974	
.XX ± .01		TITLE: T-1 (3mm) LED CLIP AND RING SET	
.XXX ± .005		PART NO: CR-101	
DESIGNED: S. Dam	DATE: 01/23/07	REVISION: D	
CHECKED: T. Yin	DATE: 01/23/07	CAGE CODE : 32559 SHEET # 1 OF 1	
CAD GENERATED DOCUMENT. DO NOT MEASURE DRAWING.			