

VFM Step-Up DC/DC Converter

General Description

The RT9261B Series are VFM Step-up DC/DC converter ICs with ultra low supply current by CMOS process and suitable for use with battery-powered instruments.

The RT9261B IC consists of an oscillator, a VFM control circuit, a driver transistor (LX switch), a reference voltage unit, an error amplifier, resistors for voltage detection, and a LX switch protection circuit. A low ripple and high efficiency step-up DC/DC converter can be constructed with the RT9261B IC and only three external components.

The EN pin enables the circuit to set the standby supply current at a maximum of 0.5µA.

Ordering Information

RT9261B-□□□□	
	Package Type
	B : SOT-23-5
	X : SOT-89
	Lead Plating System
	P : Pb Free
	G : Green (Halogen Free and Pb Free)
	Output Voltage
	15 : 1.5V
	16 : 1.6V
	:
	49 : 4.9V
	50 : 5.0V

Note :

Richtek products are :

- ▶ RoHS compliant and compatible with the current requirements of IPC/JEDEC J-STD-020.
- ▶ Suitable for use in SnPb or Pb-free soldering processes.

Marking Information

For marking information, contact our sales representative directly or through a Richtek distributor located in your area.

Features

- Minimal Number of External Components (Only an Inductor, a Diode, and a Capacitor)
- Ultra Low Input Current (6.5µA at Switch Off)
- Capable of Supplying 50mA Output Current with Internal Switch
- ± 2% Output Voltage Accuracy
- Low Ripple and Low Noise
- Low Start-up Voltage, 0.8V at 1mA
- 80% Efficiency with Low Cost Inductor
- +50 ppm/°C Low Temperature-Drift
- SOT-89 and SOT-23-5 Small Packages
- RoHS Compliant and 100% Lead (Pb)-Free

Applications

- Power source for battery-powered equipment
- Power source for cameras, camcorders, VCRs, PDAs, pagers, electronic data banks, and hand-held communication equipment
- Power source for appliances, which require higher voltage than that of batteries used in the appliances

Pin Configurations

(TOP VIEW)

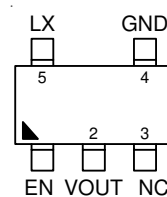

SOT-23-5

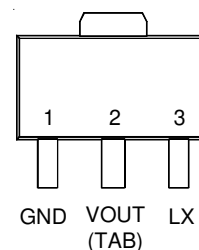

SOT-89

Typical Application Circuit

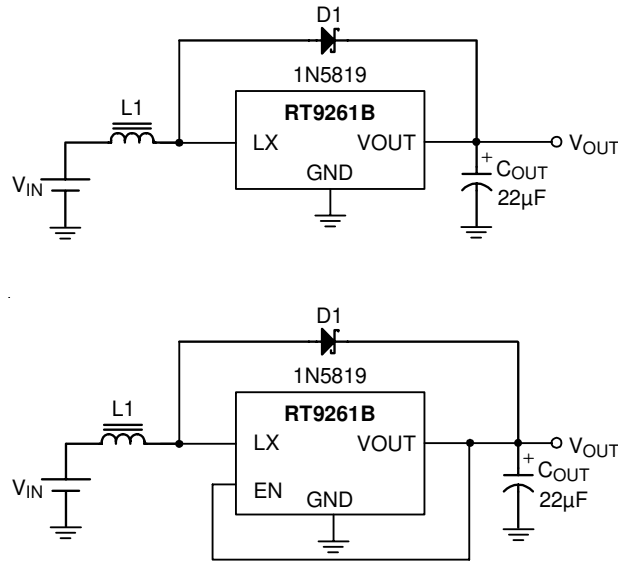

* L1 ranges from 27µH to 120µH

Functional Pin Description

Pin No.		Pin Name	Pin Function
SOT-23-5	SOT-89		
1	--	EN	Chip Enable (Active High).
2	2	VOUT	Output Voltage.
3	--	NC	No Internal Connection.
4	1	GND	Ground.
5	3	LX	Pin for Switching.

Function Block Diagram

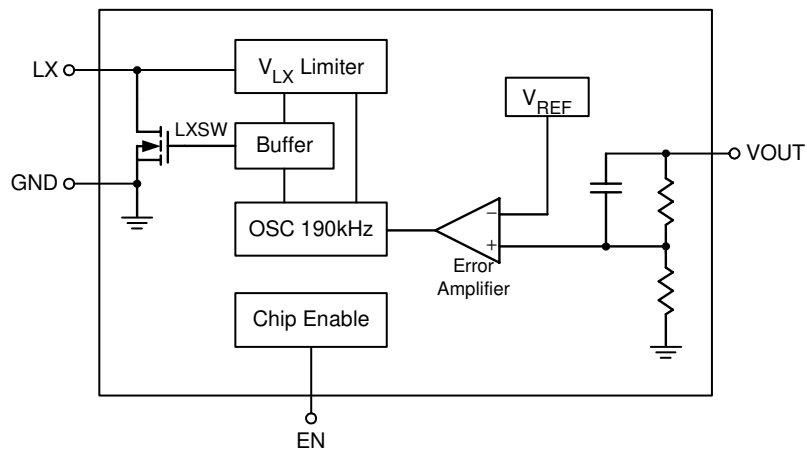

Absolute Maximum Ratings

- Output Voltage ----- 8V
- LX Pin Voltage ----- 8V
- EN Pin Voltage⁽¹⁾ ----- -0.3 to V_{OUT} +0.3V
- LX Pin Output Current ----- 400mA
- Power Dissipation, P_D @ T_A = 25°C
 - SOT-89 ----- 0.5W
 - SOT-23-5 ----- 0.25W
- Package Thermal Resistance
 - SOT-89, θ_{JC} ----- 100°C/W
 - SOT-89, θ_{JA} ----- 300°C/W
 - SOT-23-5, θ_{JA} ----- 250°C/W
- Operating Temperature Range ----- -20 to +85°C
- Storage Temperature Range ----- -65°C to 150°C
- Lead Temperature (Soldering, 10 sec.) ----- 260°C

Notes: (1) Applicable to RT9261B-xxCB

Electrical Characteristics (Refer to Figure 1)

Parameter	Symbol	Test Conditions	Min	Typ	Max	Unit	
Output Voltage Accuracy	ΔV _{OUT}		-2	--	+2	%	
Input Voltage	V _{IN}		--	--	7	V	
Start-up Voltage	V _{ST}	I _{OUT} = 1mA, V _{IN} : 0 → 2V	--	0.8	1	V	
Hold-on Voltage	V _{HO}	I _{OUT} = 1mA, V _{IN} : 2 → 0V	0.7	--	--	V	
Input Current 1		V _{IN} in continuous switching	V _{OUT} ≤ 3.5V ⁽¹⁾	--	24	36	μA
			3.5V < V _{OUT} ≤ 5V ⁽²⁾	--	36	45	
Input Current 2 ⁽¹⁾⁽²⁾		V _{OUT} in switch off condition	--	6.5	10	μA	
Input Current 3 (guaranteed by I ₁ and I ₂)		V _{IN} in no load	V _{OUT} ≤ 3.5V ⁽¹⁾	--	18	36	μA
			3.5V < V _{OUT} ≤ 5V ⁽²⁾	--	20	45	
LX Switching Current	I _{SWITCHING}	V _{LX} = 0.4V	V _{OUT} ≤ 3.5V ⁽¹⁾	120	--	--	mA
			3.5V < V _{OUT} ≤ 5V ⁽²⁾	160	--	--	
LX Leakage Current	I _{LEAKAGE}	V _{LX} = 6V	--	--	0.5	μA	
Maximum Oscillator Frequency	F _{MAX}	V _{OUT} = 2.5V to 5V	140	190	240	kHz	
		V _{OUT} = 1.5V to 2.4V	140	190	320		
Oscillator Duty Cycle	D _{OSC}	On (V _{LX} "L" side)	V _{OUT} = 2.5V to 5V	65	75	85	%
			V _{OUT} = 1.5V to 2.4V	60	70	80	
Efficiency			--	80	--	%	
V _{LX} Voltage Limit		LX switch on	0.65	0.8	1.0	V	

Notes:

(1) V_{IN} = 1.8V, V_{SS} = 0V, I_{OUT} = 1mA, T_{opt} = 25°C, and use External Circuit of Typical Application

(2) V_{IN} = 3V, V_{SS} = 0V, I_{OUT} = 1mA, T_{opt} = 25°C, and External Circuit of Typical Application

Electrical Characteristics (Refer to Figure 2)

Parameter	Symbol	Test Conditions	Min	Typ	Max	Unit	
Output Voltage Accuracy	ΔV_{OUT}		-2	--	+2	%	
Input Voltage	V_{IN}		--	--	7	V	
Start-up Voltage	V_{ST}	$I_{OUT} = 1\text{mA}$, $V_{IN}: 0 \rightarrow 2\text{V}$	--	0.8	1	V	
Hold-on Voltage	V_{HO}	$I_{OUT} = 1\text{mA}$, $V_{IN}: 2 \rightarrow 0\text{V}$	0.7	--	--	V	
Efficiency			--	80	--	%	
Input Current 1		V_{IN} in continuous switching	$V_{OUT} \leq 3.5\text{V}^{(1)}$	--	24	36	μA
			$3.5\text{V} < V_{OUT} \leq 5\text{V}^{(2)}$	--	36	45	
Input Current 2 ⁽¹⁾⁽²⁾		V_{OUT} in switch off condition	--	6.5	10	μA	
Input Current 3 (guaranteed by I_1 and I_2)		V_{IN} in no load	$V_{OUT} \leq 3.5\text{V}^{(1)}$	--	18	36	μA
			$3.5\text{V} < V_{OUT} \leq 5\text{V}^{(2)}$	--	20	45	
LX Switching Current	$I_{SWITCHING}$	$V_{LX} = 0.4\text{V}$	$V_{OUT} \leq 3.5\text{V}^{(1)}$	120	--	--	mA
			$3.5\text{V} < V_{OUT} \leq 5\text{V}^{(2)}$	160	--	--	
LX Leakage Current	$I_{LEAKAGE}$	$V_{LX} = 6\text{V}$	--	--	0.5	μA	
EN "H" Level		$V_{IN} = V_{OUT} * 0.9$	$0.4 \times V_{OUT}$	--	--	V	
EN "L" Level		$V_{IN} = V_{OUT} * 0.9$	--	--	0.2	V	
EN "H" Input Current		$EN = V_{OUT}$	--	--	0.5	μA	
EN "L" Input Current		$EN = 0\text{V}$	-0.5	--	--	μA	
Maximum Oscillator Frequency	F_{MAX}	$V_{OUT} = 2.5\text{V to } 5\text{V}$	140	190	240	kHz	
		$V_{OUT} = 1.5\text{V to } 2.4\text{V}$	140	190	320		
Oscillator Duty Cycle	D_{OSC}	On (V_{LX} "L") side	$V_{OUT} = 2.5\text{V to } 5\text{V}$	65	75	85	%
			$V_{OUT} = 1.5\text{V to } 2.4\text{V}$	60	70	80	%
V_{LX} Voltage Limit		LX switch on	0.65	0.8	1.0	V	

Notes:

(1) $V_{IN} = 1.8\text{V}$, $V_{SS} = 0\text{V}$, $I_{OUT} = 1\text{mA}$, $T_{opt} = 25^\circ\text{C}$, and use External Circuit of Typical Application

(2) $V_{IN} = 3\text{V}$, $V_{SS} = 0\text{V}$, $I_{OUT} = 1\text{mA}$, $T_{opt} = 25^\circ\text{C}$, and External Circuit of Typical Application

Typical Operating Characteristics

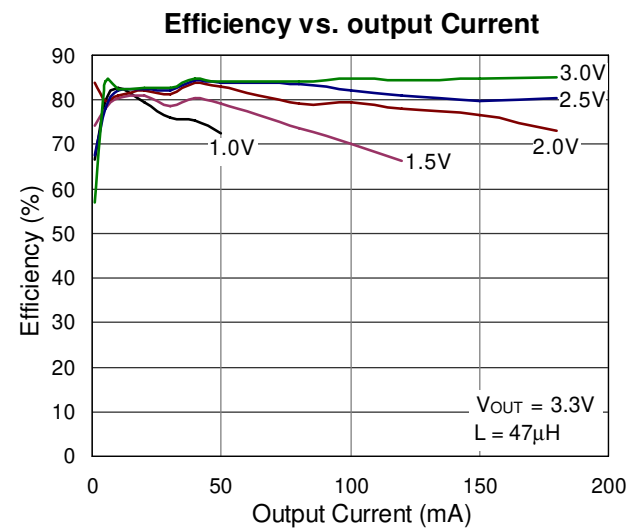
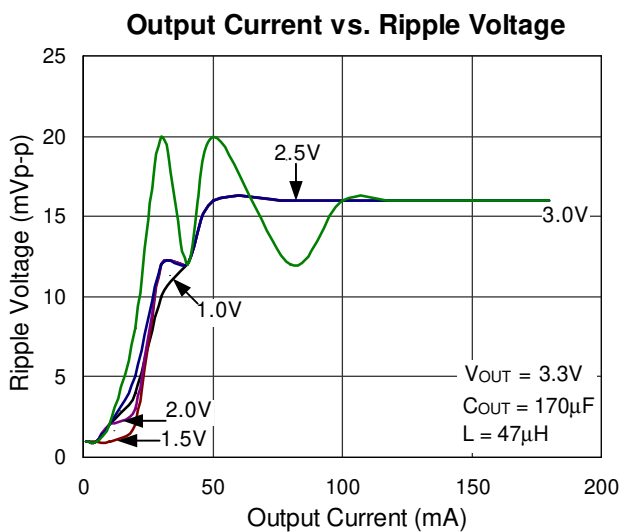
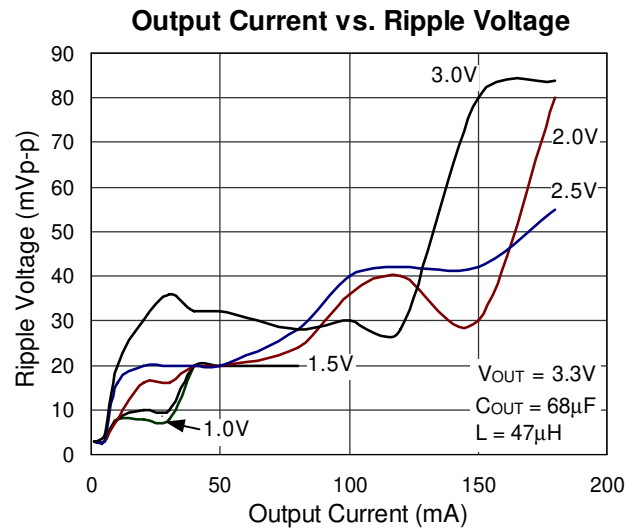
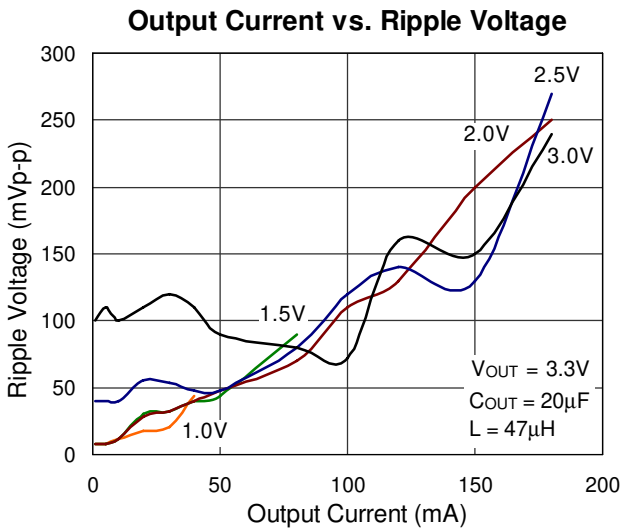
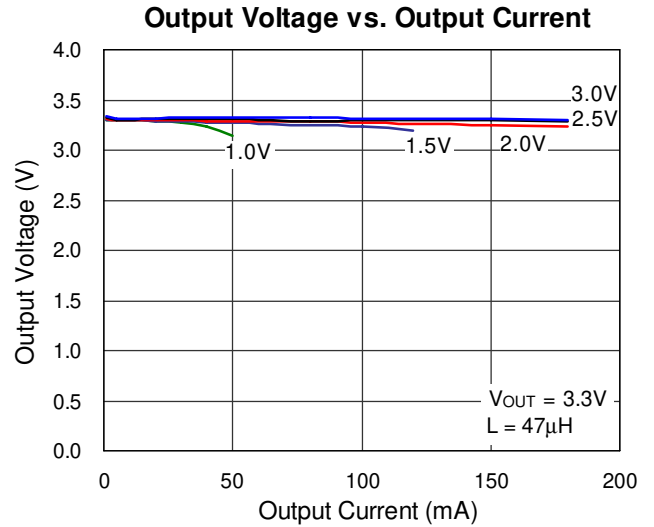
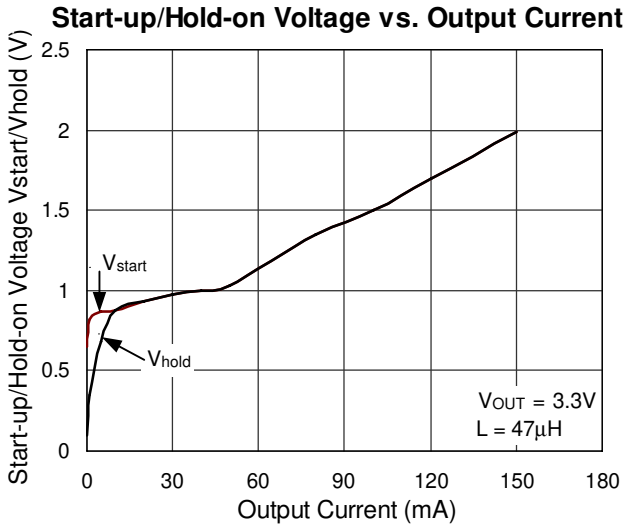

Start-up/Hold-on Voltage vs. Output Current

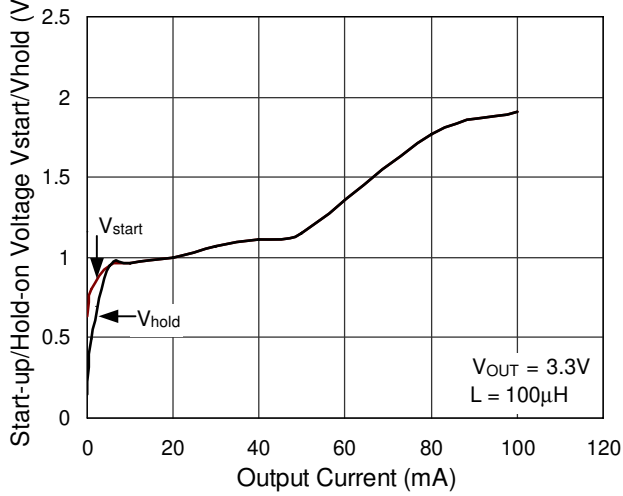

Output Voltage vs. Output Current

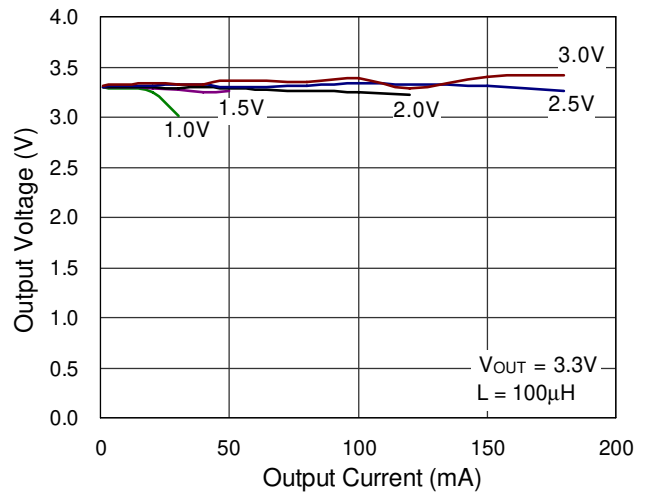

Output Current vs. Ripple Voltage

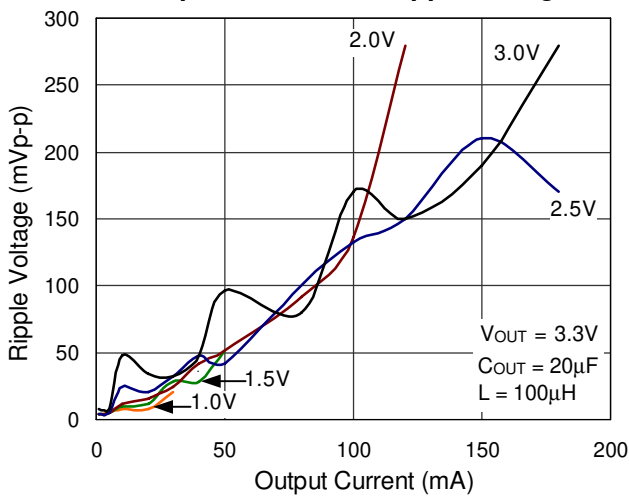

Output Current vs. Ripple Voltage

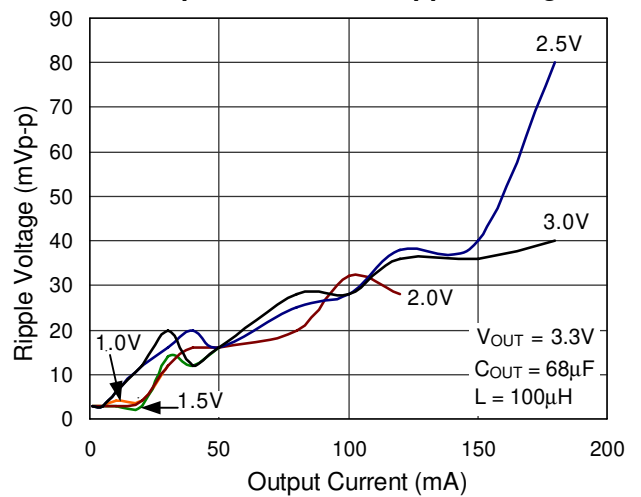

Output Current vs. Ripple Voltage

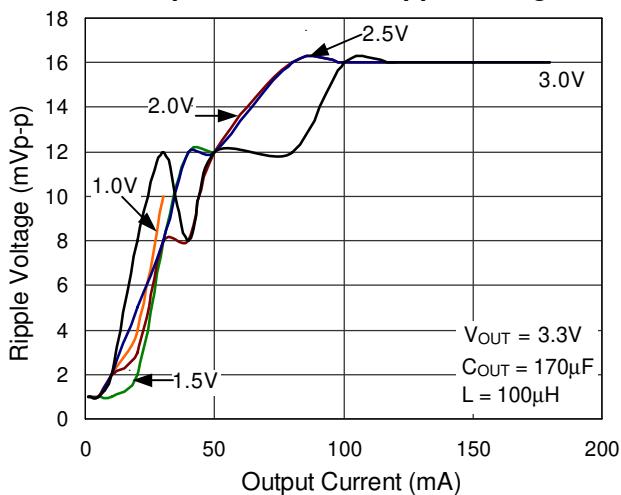

Efficiency vs. output Current

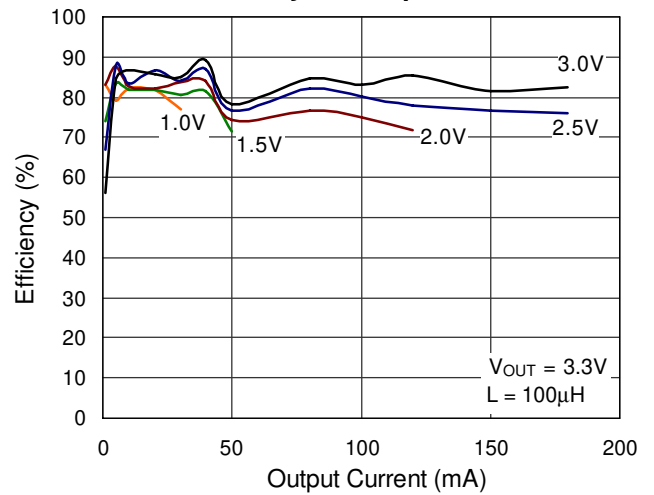

Outline Dimension

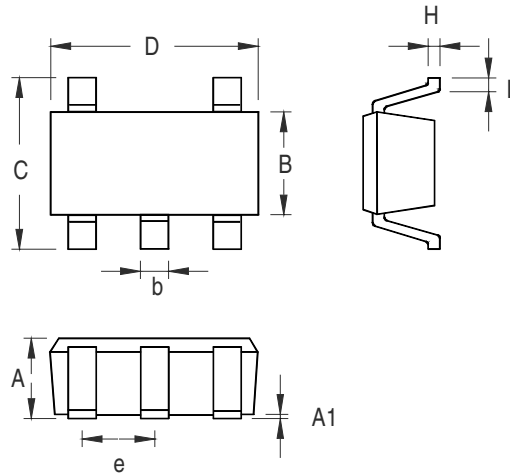

Symbol	Dimensions In Millimeters		Dimensions In Inches	
	Min	Max	Min	Max
A	0.889	1.295	0.035	0.051
A1	0.000	0.152	0.000	0.006
B	1.397	1.803	0.055	0.071
b	0.356	0.559	0.014	0.022
C	2.591	2.997	0.102	0.118
D	2.692	3.099	0.106	0.122
e	0.838	1.041	0.033	0.041
H	0.080	0.254	0.003	0.010
L	0.300	0.610	0.012	0.024

SOT-23-5 Surface Mount Package

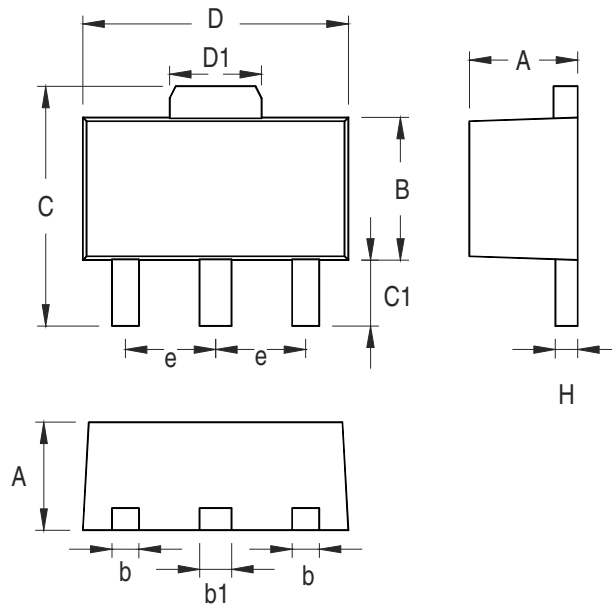

Symbol	Dimensions In Millimeters		Dimensions In Inches	
	Min	Max	Min	Max
A	1.397	1.600	0.055	0.063
b	0.356	0.483	0.014	0.019
B	2.388	2.591	0.094	0.102
b1	0.406	0.533	0.016	0.021
C	3.937	4.242	0.155	0.167
C1	0.787	1.194	0.031	0.047
D	4.394	4.597	0.173	0.181
D1	1.397	1.753	0.055	0.069
e	1.448	1.549	0.057	0.061
H	0.356	0.432	0.014	0.017

3-Lead SOT-89 Surface Mount

Richtek Technology Corporation

Headquarter
 5F, No. 20, Taiyuen Street, Chupei City
 Hsinchu, Taiwan, R.O.C.
 Tel: (8863)5526789 Fax: (8863)5526611

Richtek Technology Corporation

Taipei Office (Marketing)
 5F, No. 95, Minchiuan Road, Hsintien City
 Taipei County, Taiwan, R.O.C.
 Tel: (8862)86672399 Fax: (8862)86672377
 Email: marketing@richtek.com

Information that is provided by Richtek Technology Corporation is believed to be accurate and reliable. Richtek reserves the right to make any change in circuit design, specification or other related things if necessary without notice at any time. No third party intellectual property infringement of the applications should be guaranteed by users when integrating Richtek products into any application. No legal responsibility for any said applications is assumed by Richtek.