

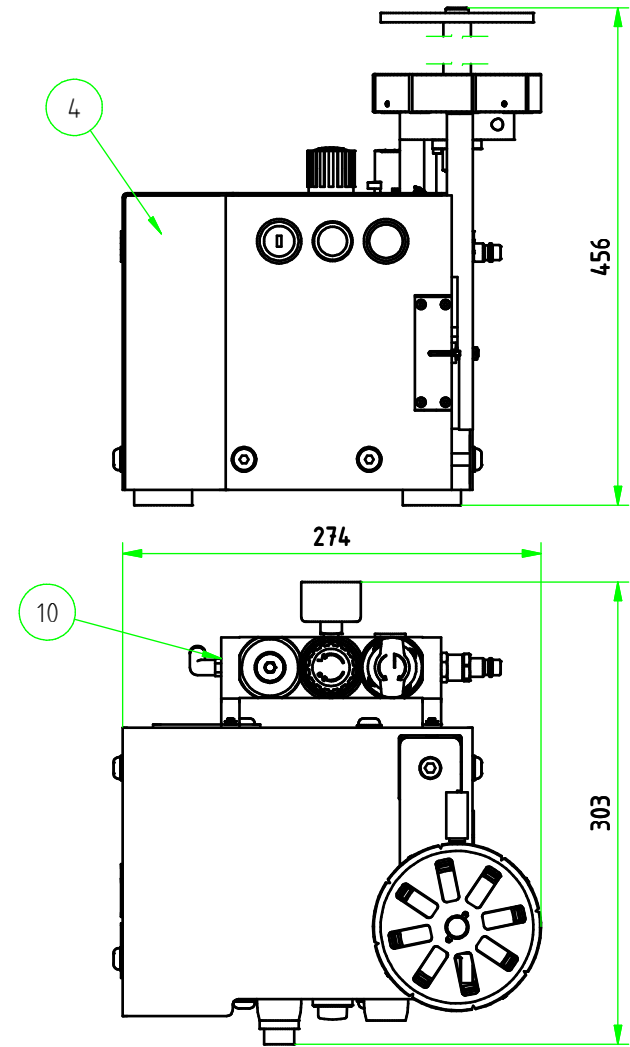

REVISIONS

P	LTR	DESCRIPTION	DATE	DWN	APVD
	B	INITIAL REVISION	18MAR16	LS	LB

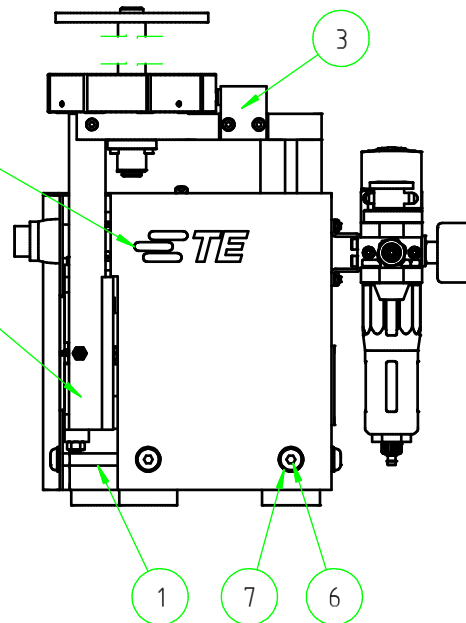
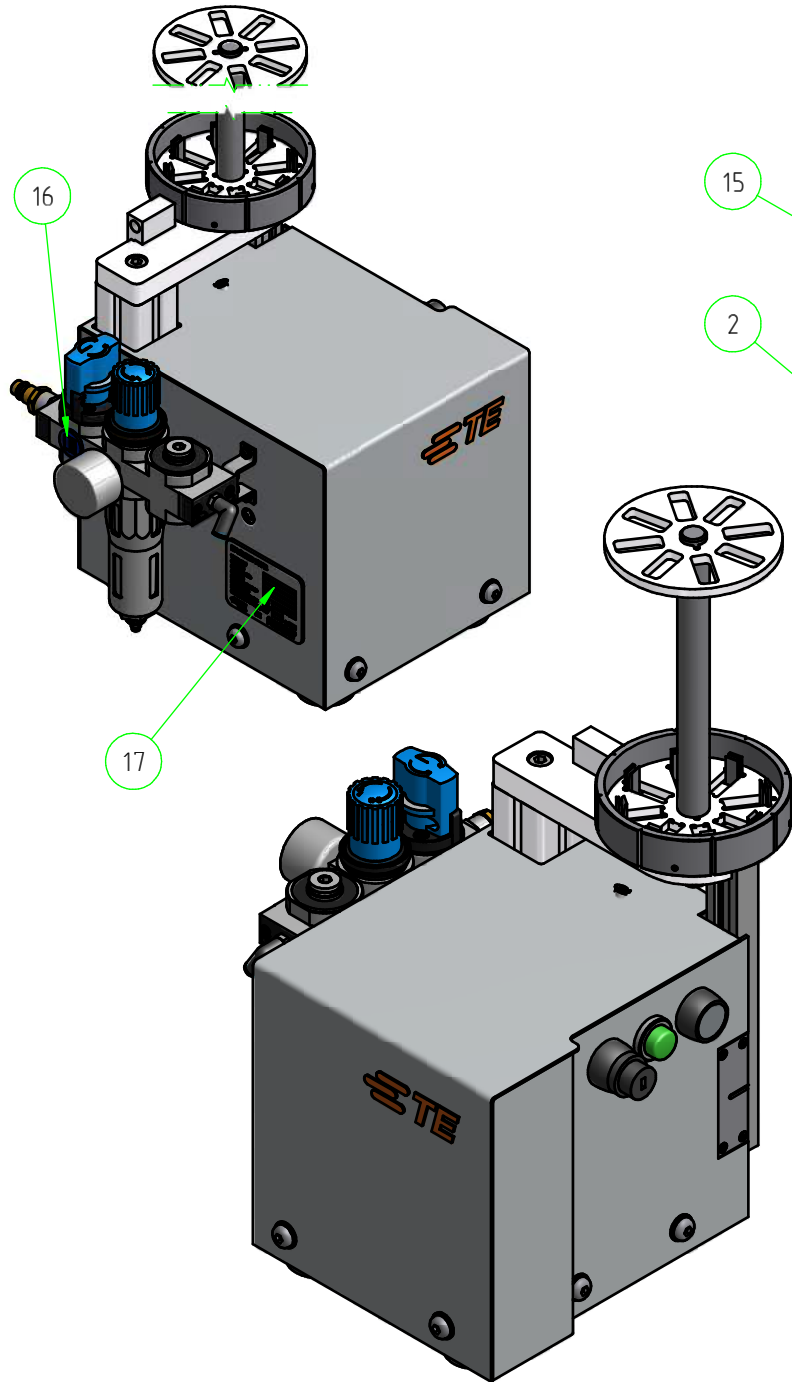

USED FOR CONNECTOR SYSTEM:
180 DEG IDC PLUG IN HE 1302/1402
Series,

TE 114-15031

THIS DRAWING IS A CONTROLLED DOCUMENT.		DWN L.Sandhu 18MAR2016	 TE Connectivity														
DIMENSIONS: mm		CHK L.Sandhu 18MAR2016															
TOLERANCES UNLESS OTHERWISE SPECIFIED:		APVD L. Bauer 18MAR2016	NAME BENCH PRESS HE14 180 DEGREE Tischpresse														
<table border="1"> <tr> <td>0 PLC</td> <td>±</td> </tr> <tr> <td>1 PLC</td> <td>±</td> </tr> <tr> <td>2 PLC</td> <td>±</td> </tr> <tr> <td>3 PLC</td> <td>±</td> </tr> <tr> <td>4 PLC</td> <td>±</td> </tr> <tr> <td>ANGLES</td> <td>±</td> </tr> </table>		0 PLC	±	1 PLC	±	2 PLC	±	3 PLC	±	4 PLC	±	ANGLES	±	PRODUCT SPEC	SIZE A3		
0 PLC	±																
1 PLC	±																
2 PLC	±																
3 PLC	±																
4 PLC	±																
ANGLES	±																
MATERIAL		FINISH	CAGE CODE 00779	DRAWING NO 949300-3	RESTRICTED TO												
		Gewicht / Weight in Kg 15	SCALE 1:3														
		CUSTOMER DRAWING		SHEET 1 OF 2	REV B												

