

DESCRIPTION

The MP26056 is a linear, high performance single cell Li-Ion or Li-Polymer battery charger with dual programmable constant current set. By integrating high voltage input protection into the charger IC, the MP26056 can tolerate an input surge up to 28V.

The device features constant current (CC), constant voltage (CV) charging modes, and reverse current blocking. The other features include the programmable battery full threshold, supporting dual AC/USB input by automatically change to a lower charge current when USB is the power supply. MP26056 also provides ACOK and charge status indications to the system. MP26056 works as an LDO charger when MOD is LOW or works as a charger with auto-termination and re-charger function when MOD is set HIGH.

For guaranteed safe operation, the MP26056 limits the die temperature to a preset value when the device is heated up due to limited PCB space. Other safety features are battery temperature monitoring, and programmable timer to prevent prolonged charging a dead battery.

MP26056 is available in 10-pin 3mm x 3mm DFN packages.

ELECTRICAL SPECIFICATION

Parameter	Symbol	Value	Units
Input Voltage	V_{IN}	5	V
Charge Current	I_{CHG}	0.2-1.0	A

FEATURES

- Input Surge up to 28V
- Works as LDO when AC adaptor is used.
- Low standby current (120uA) when USB power is used.
- Input polarity reverse protection down to -16V
- Wide input operating range 3.5V – 6.5V
- Adapter or USB Input with separate charge current programmability.
- Programmable Charge Current: 200mA to 1A
- 0.75% VBAT Accuracy over Temperature
- Programmable battery full threshold.
- Automatic die temperature limiting
- Fault and Charge Status Indicators

APPLICATIONS

- Cell Phones
- Digital Cameras
- Smart Phones
- PDAs
- MP3 Players

"MPS" and "The Future of Analog IC Technology" are Registered Trademarks of Monolithic Power Systems, Inc.

EV26056DQ-00A EVALUATION BOARD



(L x W x H) 2.0" x 1.9" x 0.5"
5.0cm x 4.8cm x 1.3cm

Board Number	MPS IC Number
EV26056DQ-00A	MP26056DQ

I-V Charge Curve

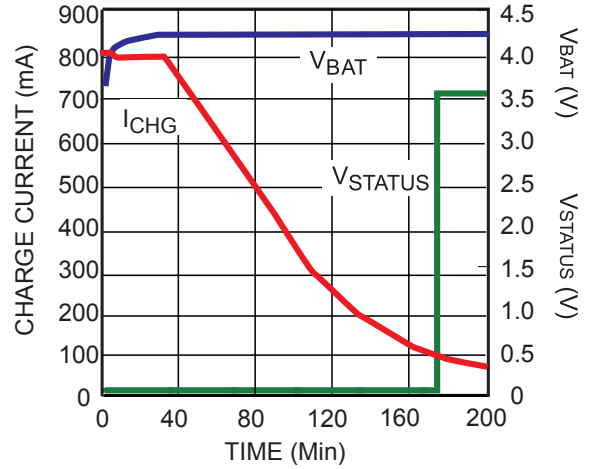

EVALUATION BOARD SCHEMATIC

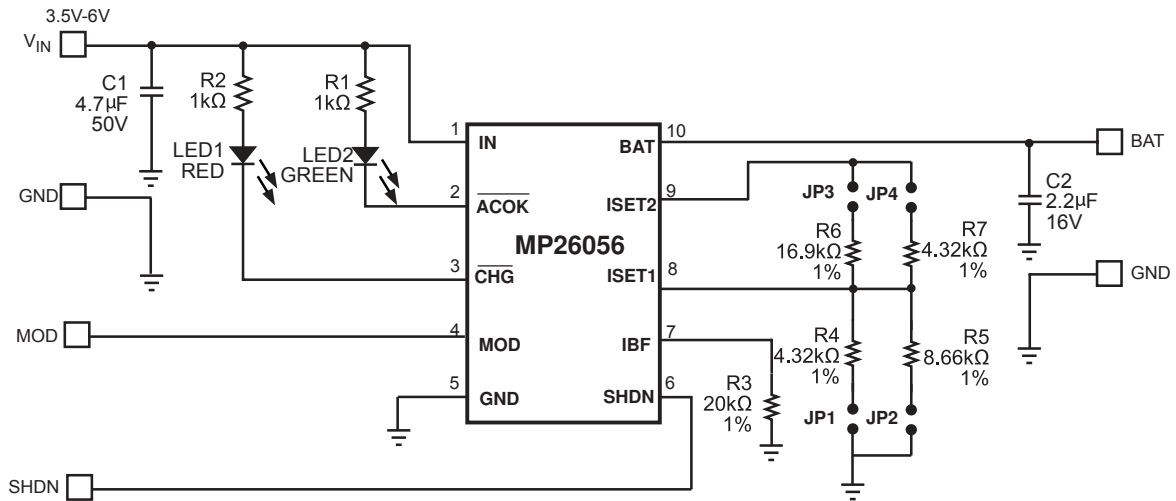

EV26056DQ-00A BILL OF MATERIALS

Qty	Ref	Value	Description	Package	Manufacturer P/N
1	C1	4.7µF	Ceramic Cap., 50V, X7R	1210	muRata
1	C2	2.2µF	Ceramic Cap., 16V, X7R	1210	muRata
1	LED1		Led Red, Surface Mount	0805	Panasonic
1	LED2		Led Green, Surface Mount	0805	Panasonic
2	R1,R2	1k	Film Res., 1%	603	Panasonic
1	R3	20K	Film Res., 1%	603	Panasonic
2	R4, R7	4.32K	Film Res., 1%	603	Panasonic
1	R5	8.66K	Film Res., 1%	603	Panasonic
1	R6	16.9K	Film Res., 1%	603	Panasonic
1	J1		9-Pin Connector Header, 0.100"		Sullins
1	J2		5-Pin Connector Header, 0.100"		Sullins
4	JP1,~JP4		2-Pin Connector Header, 0.100"		Sullins
1	U1		Battery Charger	QFN10	MP26056DQ

PRINTED CIRCUIT BOARD LAYOUT

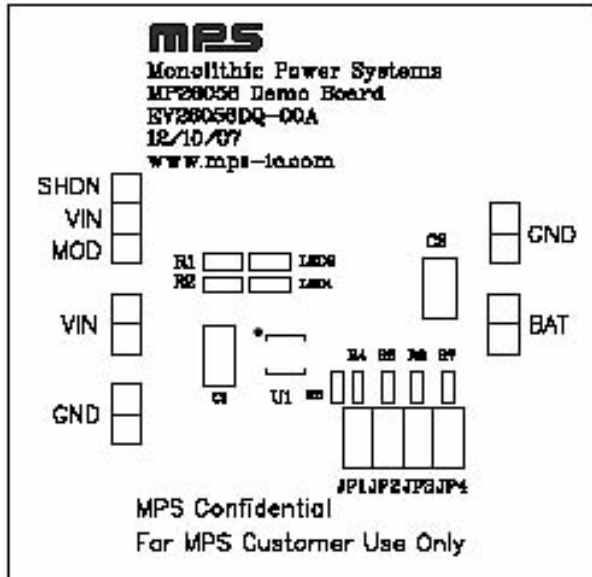

Figure 1—Top Silk Layer

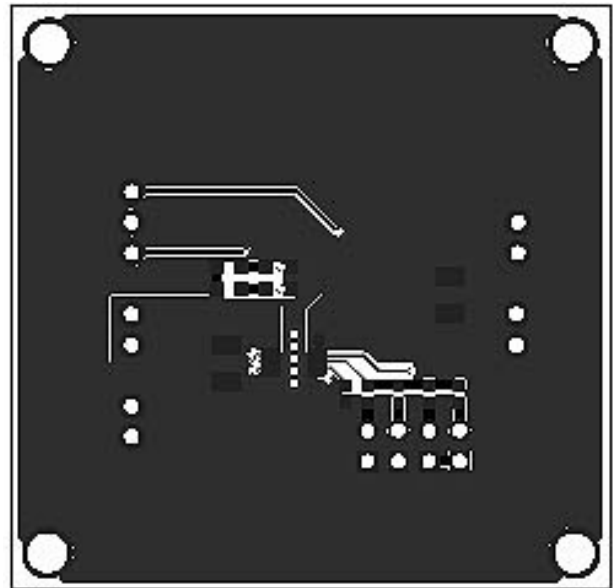

Figure 2—Top Layer

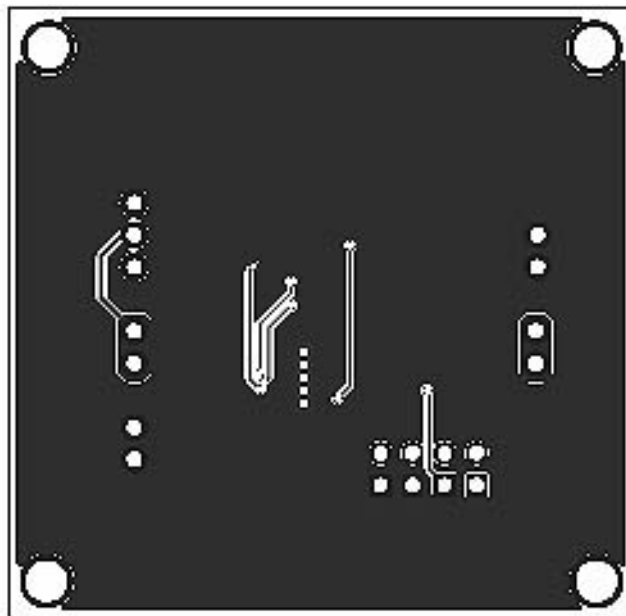

Figure 3—Bottom Layer

QUICK START GUIDE

The output voltage on this board is preset to 4.2V (for a single cell battery). The board layout accommodates most commonly used capacitors.

The LEDs are power indicators. When LED1 is on, the 5V input is present (LED1 is off when the input is disconnected). When LED2 is on, the battery is charging, and when the battery is full or there is no battery connected, LED 2 will turn off.

1. Set the charge current I_{CHG} using the jumpers JP1, JP2, JP3 and JP4 per the following table:

I_{CHG} (mA)	JP1	JP2	JP3	JP4
200		X		
300		X	X	
400	X			
500	X		X	
600	X	X		
700	X	X	X	
800	X			X
900	X		X	X
1000	X	X		X

Where “X” indicates a connection.

2. Attach the positive and negative ends of the load to the VOUT and GND pins, respectively.
3. Attach the input voltage ($V_{IN}=5V$) and the input ground to the VIN and GND pins, respectively.
4. MOD Control voltage “High” for USB input or “Low” for AC adapter input.
5. Set the battery full threshold IBF using R3:

$$I_{BF} = \frac{1A \times 1.7k\Omega}{R3}$$

NOTICE: The information in this document is subject to change without notice. Please contact MPS for current specifications. Users should warrant and guarantee that third party Intellectual Property rights are not infringed upon when integrating MPS products into any application. MPS will not assume any legal responsibility for any said applications.