

ITEM	MOLEX P/N:	DESCRIPTION	PLATING SPEC:
1	76546-0004	3-CKT CONNECTOR TIN PLATING (CONTACT AREA)	0.00254 MATTE TIN OVERALL, OVER 0.00127 NICKEL.
2	76546-0005	3-CKT CONNECTOR GOLD PLATING (CONTACT AREA ONLY)	0.000127 NICKEL OVERALL WITH 0.00254 MATTE TIN ON TAILS AND 0.000762 SELECTIVE GOLD ON CONTACT AREA.
3	76546-0006	3-CKT CONNECTOR TIN PLATING (CONTACT AREA)	0.00254 MATTE TIN OVERALL (PREVIOUSLY TIN/LEAD), OVER 0.00127 NICKEL.
4	76546-0007	3-CKT CONNECTOR GOLD PLATING (CONTACT AREA ONLY)	0.000127 NICKEL OVERALL WITH 0.00254 MATTE TIN ON TAILS AND (PREVIOUSLY TIN/LEAD) 0.000762 SELECTIVE GOLD ON CONTACT AREA.

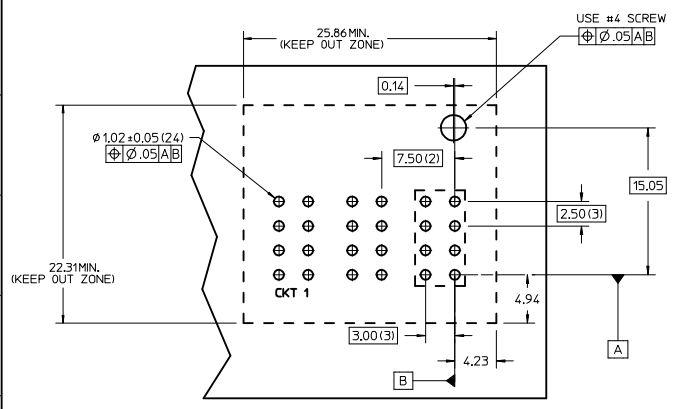
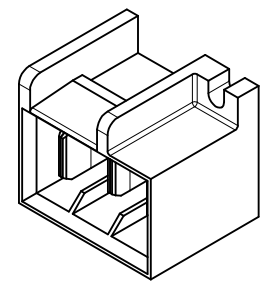
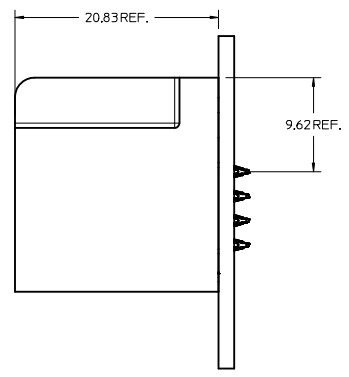
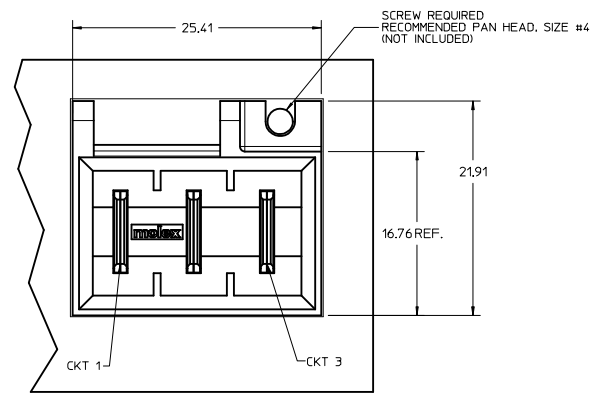

- NOTES:
- MATERIAL:
 - HOUSINGS: PBT 30% UL-94, V-0: COLOR BLACK
 - TERMINALS: COPPER ALLOY
 - PLATING: SEE CHART
 - PACKAGING: ASSEMBLIES TO BE TRAY PACKED PER PACKAGING SPEC PK-76546-xxx
 - PRODUCT SPEC: PS-46436-100
 - APPLICATION SPEC: AS-46436-100
 - PRODUCT TO MEET RoHS REQUIREMENTS
 - ASSEMBLY MATES TO MOLEX RECEPTACLE HARNESS ASSEMBLY, P/N 46586-1003
 - MATES TO 46586-0003

RECOMMENDED PCB LAYOUT AND KEEP OUT ZONE

LEADFREE CONVERTER IEC NO: UCP2013-2585 DRAWN BY: CHYKIMOLFE CHECKED BY: APPR:SMILLER DATE: 2012/11/12 DATE: 2012/12/27	QUALITY SYMBOLS ∇=0 ∇=0 ∇=0	GENERAL TOLERANCES (UNLESS SPECIFIED)		DIMENSION STYLE MM ONLY		SCALE 4:1	DESIGN UNITS METRIC	THIRD ANGLE PROJECTION
		4 PLACES ±--- ±--- 3 PLACES ±--- ±--- 2 PLACES ±0.25 ±--- 1 PLACE ±0.25 ±--- 0 PLACE ±--- ±---	mm INCH ±--- ±--- ±0.25 ±--- ±0.25 ±--- ±--- ±---	DRAWN BY: BKOSTIC CHECKED BY: BKOSTIC APPROVED BY: BKOSTIC DATE: 2007/09/10 DATE: 2007/09/10 DATE: 2007/10/10	DATE: 2007/09/10 DATE: 2007/09/10 DATE: 2007/10/10	MATERIAL NO. SEE TABLE	DOCUMENT NO. SD-76546-004	TITLE 3-CKT VERTICAL PLUG ASSY PRESS-FIT, TEN60 FAMILY, VERTICAL