



ENHANCED DIFFERENTIAL RECEIVER

SY10EL16VA-VF
SY100EL16VA-VF

- 3.3V and 5V power supply options
- 250ps propagation delay
- Very high voltage gain vs. standard EL16 or EL16V
- Ideal for Pulse Amplifier and Limiting Amplifier applications
- Data synchronous Enable/Disable (/EN) on QHG and /QHG provides for complete glitchless gating of the outputs
- Ideal for gating timing signals
- Complete solution for high quality, high frequency crystal oscillator applications
- Internal 75kΩ input pull-down resistors
- Available in both 8- and 16-pin SOIC package; 8- and 10-pin (3mm) MSOP and in DIE form

The SY10/100EL16VA-VF are differential receivers. The devices are equivalent to SY10/100EL16 or SY10/100EL16V with enhanced capabilities. The QHG, /QHG outputs have a DC gain several times larger than the DC gain of the Q output.

The SY10/100EL16VA have an identical pinout to the SY10/100EL16 or SY10/100EL16V. It provides a V_{BB} output for either single-ended application or as a DC bias for AC coupling to the device.

The SY10/100EL16VB are very similar to the SY10/100EL16VA. The /Q output is provided for feedback purposes.

The SY10/100EL16VC provides an /EN input which is synchronized with the data input (D) signal in a way that provides glitchless gating of the QHG and /QHG outputs. When the /EN signal is LOW, the input is passed to the outputs and the data output equals the data input. When the data input is HIGH and the /EN goes HIGH, it will force the QHG LOW and the /QHG HIGH on the next negative transition of the data input. If the data input is LOW when the /EN goes HIGH, the next data transition to a HIGH is ignored and QHG remains LOW and /QHG remains HIGH. The next positive transition of the data input is not passed on to the data outputs under these conditions. The QHG and /QHG outputs remain in their disabled state as long as the /EN input is held HIGH. The /EN input has no influence on the /Q output and the data input is passed on (inverted) to this output whether /EN is HIGH or LOW. This configuration is ideal for crystal oscillator applications, where the oscillator can be free running and gated on and off synchronously without adding extra counts to the output.

The SY10/100EL16VD provides the flexibility of all the combinations in DIE form, in 16-pin 150mil SOIC package or in 10-pin MSOP package. The 16-pin SOIC and 10-pin MSOP packages are ideal for prototyping DIE applications.

The SY10/100EL16VE are similar to the SY10/100EL16VB where the Q, /Q output is made available differently. In this package option, V_{BB} is no longer provided.

The SY10/100EL16VF are similar to the SY10/100EL16VC, offering the D, /D inputs rather than the V_{BB} output.

Pin	Function
D	Data Inputs
Q	Data Outputs
QHG	Data Outputs w/High Gain
V _{BB}	Reference Voltage Output
/EN	Enable Input

/EN	QHG Output
0	Data
1	Logic Low

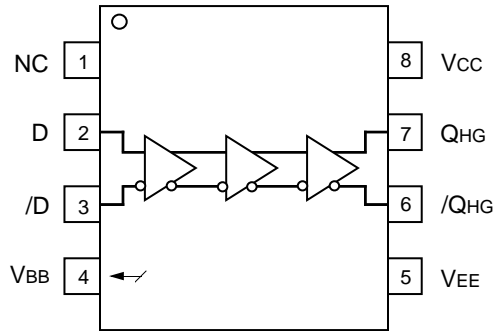

SY10/100EL16VA
5V/3.3V Differential Receiver w/High Gain
(Available in 8-pin SOIC or 8-pin MSOP)

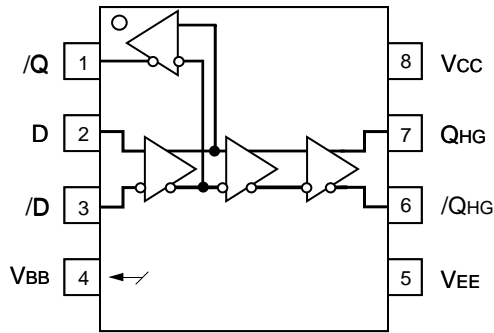

SY10/100EL16VB
EL16VA w/Extra QB output
(Available in 8-pin SOIC or 8-pin MSOP)

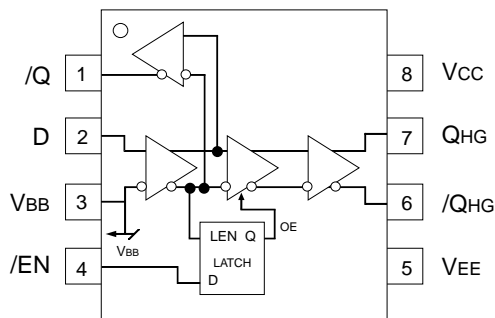

SY10/100EL16VC
EL16VB w/Enable Input
(Available in 8-pin SOIC or 8-pin MSOP)

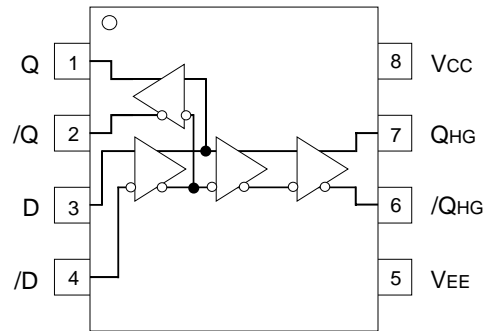

SY10/100EL16VE
EL16VB w/Differential Q, QB output (no VBB)
(Available in 8-pin SOIC or 8-pin MSOP)

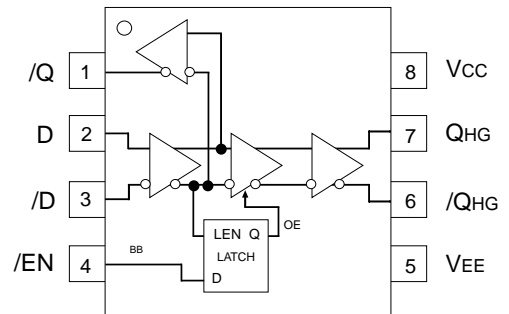

SY10/100EL16VF
EL16VC w/Differential Data Input
(Available in 8-pin SOIC or 8-pin MSOP)

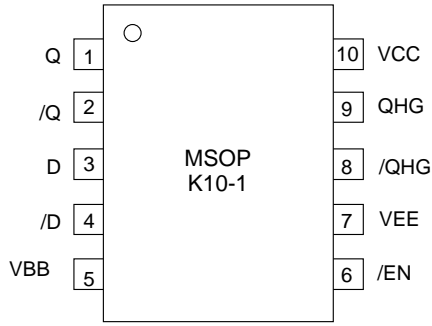

SY10/100EL16VDKC
EL16VDXC packaged in 10-pin MSOP

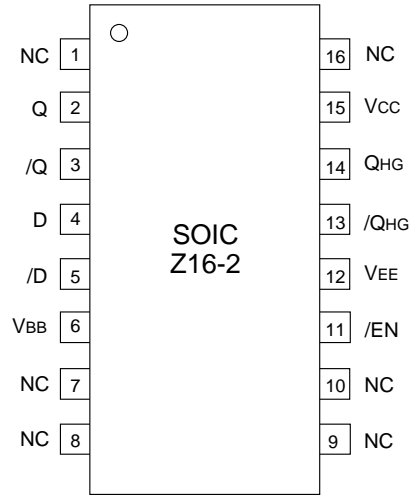

SY10/100EL16VDZC
EL16VDXC packaged in 16-pin SOIC

All options in DIE form w/Extra Q output and VBB output
Die Size (mils) 39. X 52. X 14.5

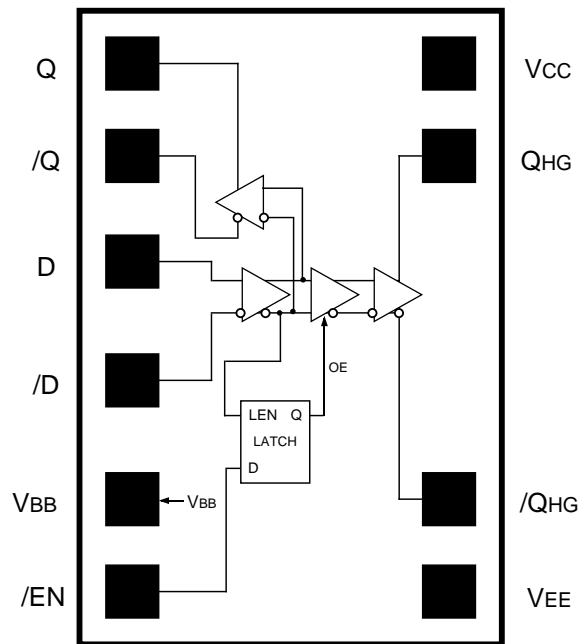

SY10/100EL16VDXC
DIE
TOP VIEW

Ordering Information⁽¹⁾

Part Number	Package Type	Operating Range	Package Marking	Lead Finish
SY10EL16VAZC	Z8-1	Commercial	HEL16VA	Sn-Pb
SY10EL16VAZCTR ⁽²⁾	Z8-1	Commercial	HEL16VA	Sn-Pb
SY100EL16VAZC	Z8-1	Commercial	XEL16VA	Sn-Pb
SY100EL16VAZCTR ⁽²⁾	Z8-1	Commercial	XEL16VA	Sn-Pb
SY10EL16VBZC	Z8-1	Commercial	HEL16VB	Sn-Pb
SY10EL16VBZCTR ⁽²⁾	Z8-1	Commercial	HEL16VB	Sn-Pb
SY100EL16VBZC	Z8-1	Commercial	XEL16VB	Sn-Pb
SY100EL16VBZCTR ⁽²⁾	Z8-1	Commercial	XEL16VB	Sn-Pb
SY10EL16VCZC	Z8-1	Commercial	HEL16VC	Sn-Pb
SY10EL16VCZCTR ⁽²⁾	Z8-1	Commercial	HEL16VC	Sn-Pb
SY100EL16VCZC	Z8-1	Commercial	XEL16VC	Sn-Pb
SY100EL16VCZCTR ⁽²⁾	Z8-1	Commercial	XEL16V	Sn-Pb
SY10EL16VDZC	Z16-2	Commercial	SY10EL16VDZC	Sn-Pb
SY10EL16VDZCTR ⁽²⁾	Z16-2	Commercial	SY10EL16VDZC	Sn-Pb
SY100EL16VDZC	Z16-2	Commercial	SY100EL16VDZC	Sn-Pb
SY100EL16VDZCTR ⁽²⁾	Z16-2	Commercial	SY100EL16VDZC	Sn-Pb
SY10EL16VEZC	Z8-1	Commercial	HEL16VE	Sn-Pb
SY10EL16VEZCTR ⁽²⁾	Z8-1	Commercial	HEL16VE	Sn-Pb
SY100EL16VEZC	Z8-1	Commercial	XEL16VE	Sn-Pb
SY100EL16VEZCTR ⁽²⁾	Z8-1	Commercial	XEL16VE	Sn-Pb
SY10EL16VFZC	Z8-1	Commercial	HEL16VF	Sn-Pb
SY10EL16VFZCTR ⁽²⁾	Z8-1	Commercial	HEL16VF	Sn-Pb
SY100EL16VFZC	Z8-1	Commercial	XEL16VF	Sn-Pb
SY100EL16VFZCTR ⁽²⁾	Z8-1	Commercial	XEL16VF	Sn-Pb
SY10EL16VAZI ⁽²⁾	Z8-1	Industrial	HEL16VA	Sn-Pb
SY10EL16VAZITR ^(1,2)	Z8-1	Industrial	HEL16VA	Sn-Pb
SY100EL16VAZI ⁽²⁾	Z8-1	Industrial	XEL16VA	Sn-Pb
SY100EL16VAZITR ^(1,2)	Z8-1	Industrial	XEL16VA	Sn-Pb
SY10EL16VBZI ⁽²⁾	Z8-1	Industrial	HEL16VB	Sn-Pb
SY10EL16VBZITR ^(1,2)	Z8-1	Industrial	HEL16VB	Sn-Pb
SY100EL16VBZI ⁽²⁾	Z8-1	Industrial	XEL16VB	Sn-Pb
SY100EL16VBZITR ^(1,2)	Z8-1	Industrial	XEL16VB	Sn-Pb
SY10EL16VCZI ⁽²⁾	Z8-1	Industrial	HEL16VC	Sn-Pb
SY10EL16VCZITR ^(1,2)	Z8-1	Industrial	HEL16VC	Sn-Pb
SY100EL16VCZI ⁽²⁾	Z8-1	Industrial	XEL16VC	Sn-Pb
SY100EL16VCZITR ⁽²⁾	Z8-1	Industrial	XEL16VC	Sn-Pb

Notes:

1. Contact factory for die availability. Dice are guaranteed at $T_A = 25^\circ\text{C}$, DC Electricals only.
2. Tape and Reel.
3. Pb-Free package is recommended for new designs.

Ordering Information⁽¹⁾

Part Number	Package Type	Operating Range	Package Marking	Lead Finish
SY10EL16VDZI	Z16-2	Industrial	SY10EL16VDZI	Sn-Pb
SY10EL16VDZITR ⁽²⁾	Z16-2	Industrial	SY10EL16VDZI	Sn-Pb
SY100EL16VDZI	Z16-2	Industrial	SY100EL16VDZI	Sn-Pb
SY100EL16VDZITR ⁽²⁾	Z16-2	Industrial	SY100EL16VDZI	Sn-Pb
SY10EL16VEZI	Z8-1	Industrial	HEL16VE	Sn-Pb
SY10EL16VEZITR ⁽²⁾	Z8-1	Industrial	HEL16VE	Sn-Pb
SY100EL16VEZI	Z8-1	Industrial	XEL16VE	Sn-Pb
SY100EL16VEZITR ⁽²⁾	Z8-1	Industrial	XEL16VE	Sn-Pb
SY10EL16VFZI	Z8-1	Industrial	HEL16VF	Sn-Pb
SY10EL16VFZITR ⁽²⁾	Z8-1	Industrial	HEL16VF	Sn-Pb
SY100EL16VFZI	Z8-1	Industrial	XEL16VF	Sn-Pb
SY100EL16VFZITR ⁽²⁾	Z8-1	Industrial	XEL16VF	Sn-Pb
SY10EL16VAZG ⁽³⁾	Z8-1	Industrial	HEL16VA with Pb-Free bar-line indicator	NiPdAu Pb-Free
SY10EL16VAZGTR ^(2, 3)	Z8-1	Industrial	HEL16VA with Pb-Free bar-line indicator	NiPdAu Pb-Free
SY100EL16VAZG ⁽³⁾	Z8-1	Industrial	XEL16VA with Pb-Free bar-line indicator	NiPdAu Pb-Free
SY100EL16VAZGTR ^(2, 3)	Z8-1	Industrial	XEL16VA with Pb-Free bar-line indicator	NiPdAu Pb-Free
SY10EL16VBZG ⁽³⁾	Z8-1	Industrial	HEL16VB with Pb-Free bar-line indicator	NiPdAu Pb-Free
SY10EL16VBZGTR ^(2, 3)	Z8-1	Industrial	HEL16VB with Pb-Free bar-line indicator	NiPdAu Pb-Free
SY100EL16VBZG ⁽³⁾	Z8-1	Industrial	XEL16VB with Pb-Free bar-line indicator	NiPdAu Pb-Free
SY100EL16VBZGTR ^(2, 3)	Z8-1	Industrial	XEL16VB with Pb-Free bar-line indicator	NiPdAu Pb-Free
SY100EL16VCKGTR ^(2, 3)	K8-1	Industrial	X16C with Pb-Free bar-line indicator	NiPdAu Pb-Free
SY10EL16VCZG ⁽³⁾	Z8-1	Industrial	HEL16VC with Pb-Free bar-line indicator	NiPdAu Pb-Free
SY10EL16VCZGTR ^(2, 3)	Z8-1	Industrial	HEL16VC with Pb-Free bar-line indicator	NiPdAu Pb-Free
SY100EL16VCZG ⁽³⁾	Z8-1	Industrial	XEL16VC with Pb-Free bar-line indicator	NiPdAu Pb-Free
SY100EL16VCZGTR ^(2, 3)	Z8-1	Industrial	XEL16VC with Pb-Free bar-line indicator	NiPdAu Pb-Free
SY100EL16VDKG	K10-1	Industrial	XEL16VD with Pb-Free bar-line indicator	NiPdAu Pb-Free
SY100EL16VDKGTR ⁽²⁾	K10-1	Industrial	XEL16VD with Pb-Free bar-line indicator	NiPdAu Pb-Free

Notes:

1. Contact factory for die availability. Dice are guaranteed at $T_A = 25^\circ\text{C}$, DC Electricals only.
2. Tape and Reel.
3. Pb-Free package is recommended for new designs.

Ordering Information⁽¹⁾

Part Number	Package Type	Operating Range	Package Marking	Lead Finish
SY10EL16VDZG ⁽³⁾	Z16-2	Industrial	SY10EL16VDZG with Pb-Free bar-line indicator	NiPdAu Pb-Free
SY10EL16VDZGTR ^(2, 3)	Z16-2	Industrial	SY10EL16VDZG with Pb-Free bar-line indicator	NiPdAu Pb-Free
SY100EL16VDZG ⁽³⁾	Z16-2	Industrial	SY100EL16VDZG with Pb-Free bar-line indicator	NiPdAu Pb-Free
SY100EL16VDZGTR ^(2, 3)	Z16-2	Industrial	SY100EL16VDZG with Pb-Free bar-line indicator	NiPdAu Pb-Free
SY10EL16VEZG ⁽³⁾	Z8-1	Industrial	HEL16VE with Pb-Free bar-line indicator	NiPdAu Pb-Free
SY10EL16VEZGTR ^(2, 3)	Z8-1	Industrial	HEL16VE with Pb-Free bar-line indicator	NiPdAu Pb-Free
SY100EL16VEZG ⁽³⁾	Z8-1	Industrial	XEL16VE with Pb-Free bar-line indicator	NiPdAu Pb-Free
SY100EL16VEZGTR ^(2, 3)	Z8-1	Industrial	XEL16VE with Pb-Free bar-line indicator	NiPdAu Pb-Free
SY10EL16VFZG ⁽³⁾	Z8-1	Industrial	HEL16VF with Pb-Free bar-line indicator	NiPdAu Pb-Free
SY10EL16VFZGTR ^(2, 3)	Z8-1	Industrial	HEL16VF with Pb-Free bar-line indicator	NiPdAu Pb-Free
SY100EL16VFZG ⁽³⁾	Z8-1	Industrial	XEL16VF with Pb-Free bar-line indicator	NiPdAu Pb-Free

Notes:

1. Contact factory for die availability. Dice are guaranteed at $T_A = 25^\circ\text{C}$, DC Electricals only.
2. Tape and Reel.
3. Pb-Free package is recommended for new designs.

VEE = VEE (Min) to VEE (Max), VCC = GND

Symbol	Parameter	TA = -40°C			TA = 0°C			TA = +25°C			TA = +85°C			Unit	
		Min.	Typ.	Max.	Min.	Typ.	Max.	Min.	Typ.	Max.	Min.	Typ.	Max.		
IEE	Power Supply Current	10EL	—	—	40	—	—	40	—	—	40	—	—	40	mA
		100EL	—	—	40	—	—	40	—	—	40	—	—	46	
VBB	Output Reference Voltage	10EL	-1.43	—	-1.30	-1.38	—	-1.27	-1.35	—	-1.25	-1.31	—	-1.19	V
		100EL	-1.38	—	-1.26	-1.38	—	-1.26	-1.38	—	-1.26	-1.38	—	-1.26	
I _{IH}	Input HIGH Current	—	—	150	—	—	150	—	—	150	—	—	150	μA	

Note:

1. Parametric values specified at: 10/100EL16VA-VF Series: -3.0V to -5.5V.

VEE = VEE (Min) to VEE (Max), VCC = GND

Symbol	Parameter	TA = -40°C			TA = 0°C			TA = +25°C			TA = +85°C			Unit
		Min.	Typ.	Max.	Min.	Typ.	Max.	Min.	Typ.	Max.	Min.	Typ.	Max.	
t _{PLH} t _{PHL}	Propagation Delay to Q, /Q Output	—	—	350	—	—	350	—	—	350	—	—	380	ps
	D (Diff)	—	—	400	—	—	400	—	—	400	—	—	430	
	D (SE)	—	—	650	—	—	650	—	—	650	—	—	730	
	QHG, /QHG Output	—	—	700	—	—	700	—	—	700	—	—	780	
t _s	Setup Time /EN	—	150	—	—	150	—	—	150	—	—	150	—	ps
t _h	Hold Time /EN	—	150	—	—	150	—	—	150	—	—	150	—	ps
t _{skew}	Duty Cycle Skew ⁽¹⁾ (Diff)	—	5	—	—	5	20	—	5	20	—	5	20	ps
V _{PP}	Minimum Input Swing ⁽²⁾	150	—	—	150	—	—	150	—	—	150	—	—	mV
V _{CMR}	Common Mode Range ⁽³⁾	-1.3	—	-0.4	-1.4	—	-0.4	-1.4	—	-0.4	-1.4	—	-0.4	V
t _r t _f	Output Q Rise/Fall Time (20% TO 80%)	100	225	350	100	225	350	100	225	350	100	225	350	ps

Notes:

1. Duty cycle skew is the difference between a t_{PLH} and t_{PHL} propagation delay through a device.
2. Minimum input swing for which AC parameters are guaranteed. The device has a DC gain of ≈ 40 to Q, /Q outputs and a DC gain of ≈ 200 or higher to /QHG/QHG outputs.
3. The CMR range is referenced to the most positive side of the differential input signal. Normal operation is obtained if the HIGH level falls within the specified range and the peak-to-peak voltage lies between V_{PP} min. and 1V. The lower end of the CMR range varies 1:1 with V_{EE}. The numbers in the spec table assume a nominal V_{EE} = -3.3V. Note for PECL operation, the V_{CMR} (min) will be fixed at 3.3V - [V_{CMR} (min)].
4. Parametric values specified at: 10/100EL16VA-VF Series: -3.0V to -5.5V.

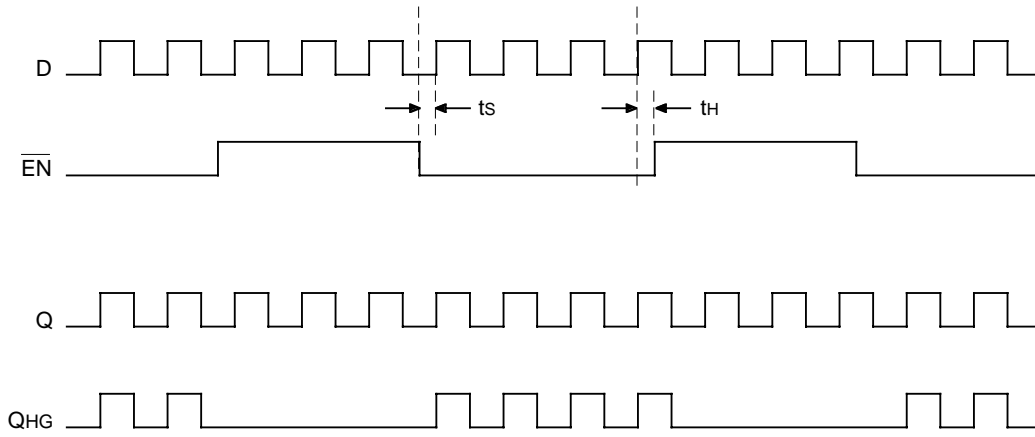

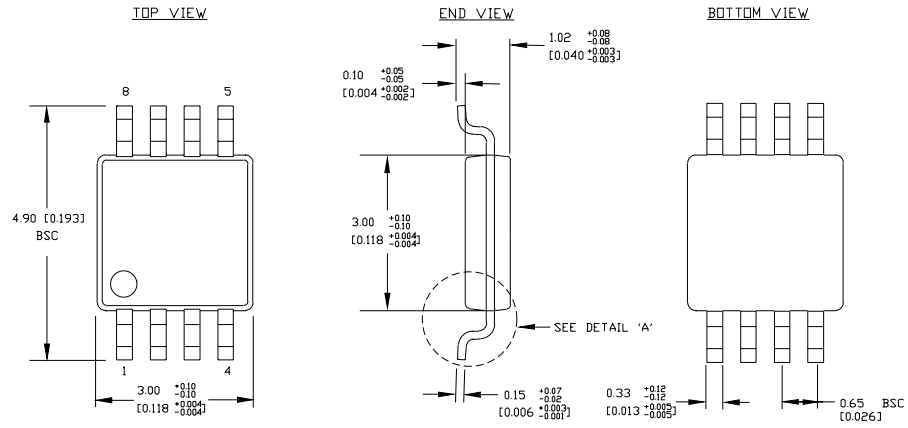

NOTES:

1. DIMENSIONS ARE IN MM [INCHES].
 2. CONTROLLING DIMENSION: MM
- DIMENSION DOES NOT INCLUDE MOLD FLASH OR PROTRUSIONS, EITHER OF WHICH SHALL NOT EXCEED 0.20 [0.008] PER SIDE.

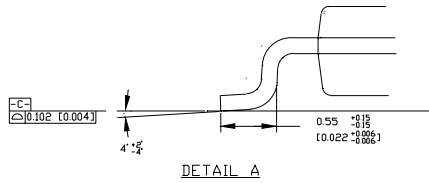

Rev. 01

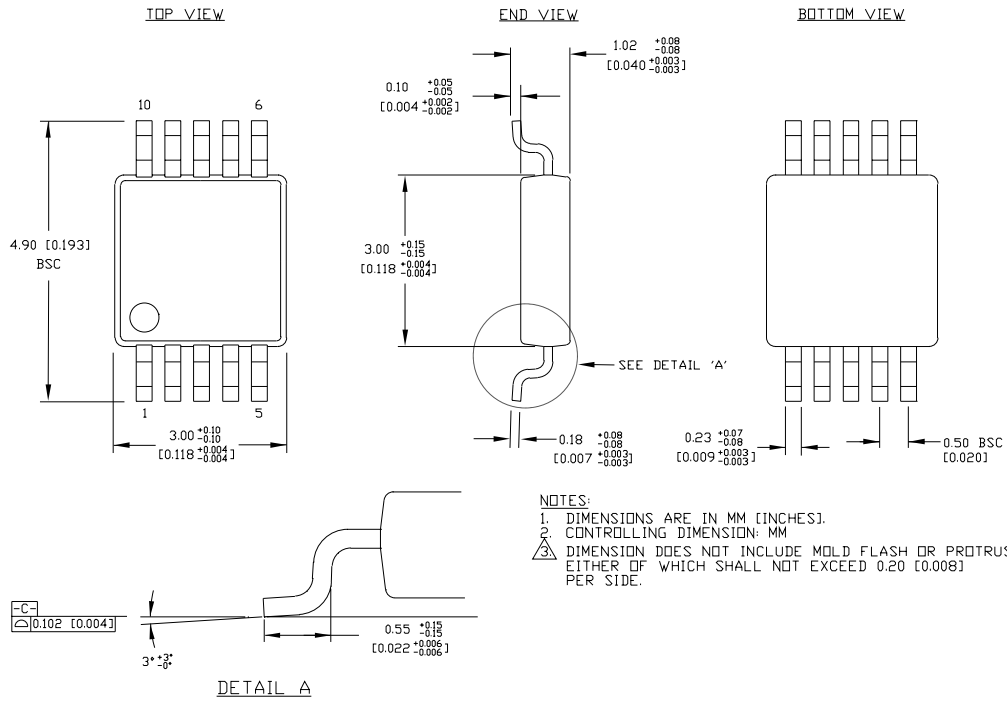

Rev. 00

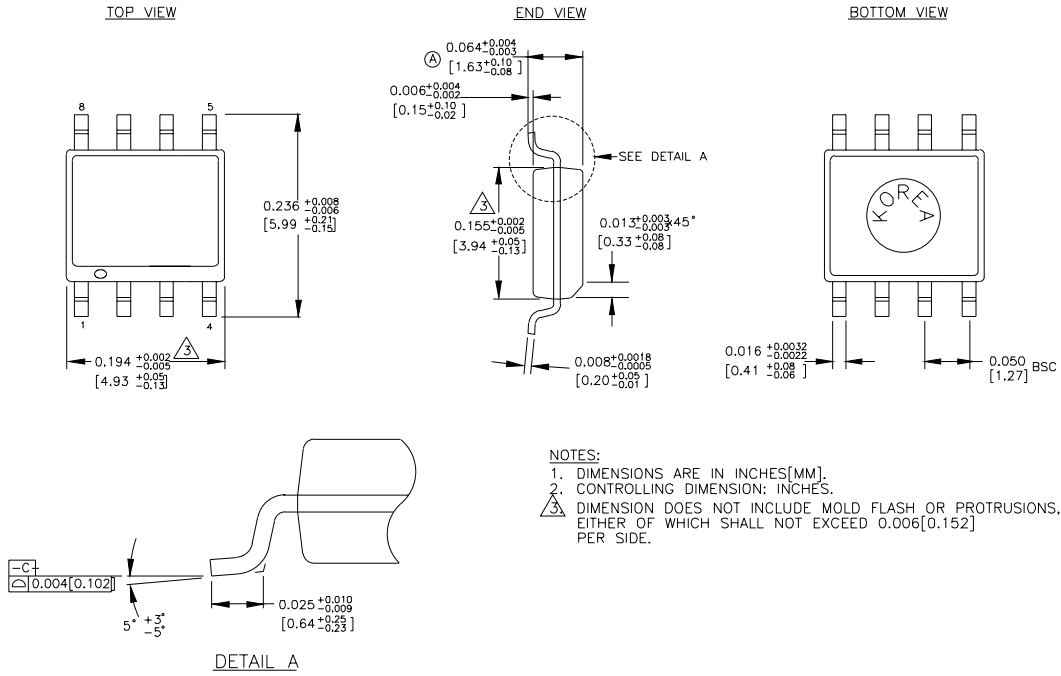

Rev.03

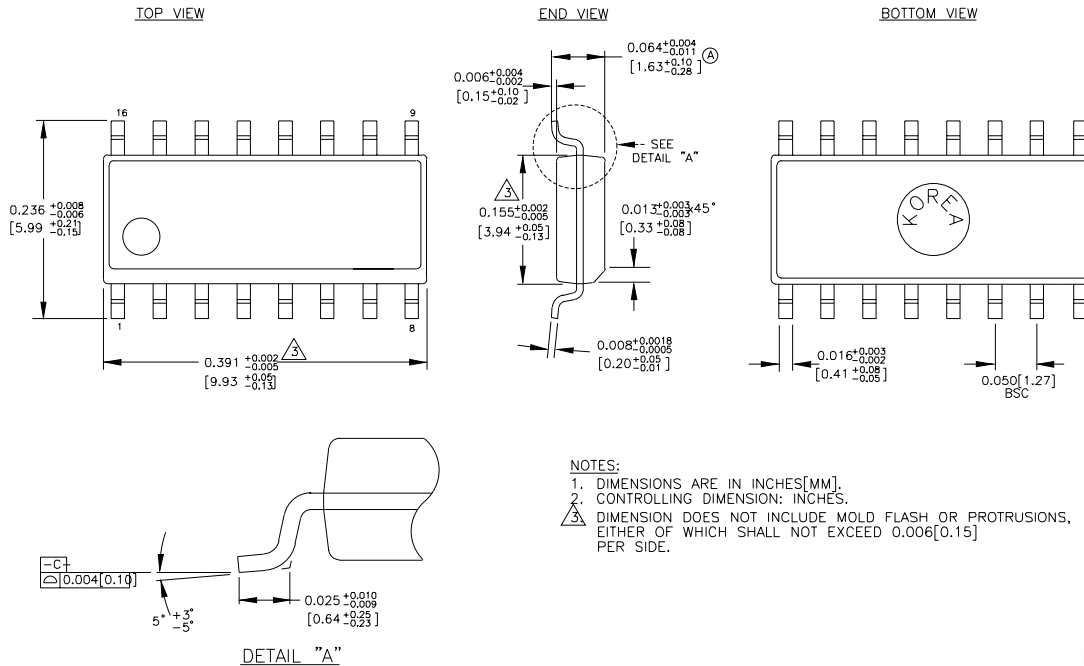

Rev. 02

MICREL, INC. 2180 FORTUNE DRIVE SAN JOSE, CA 95131 USA

TEL + 1 (408) 944-0800 FAX + 1 (408) 474-1000 WEB <http://www.micrel.com>

The information furnished by Micrel in this datasheet is believed to be accurate and reliable. However, no responsibility is assumed by Micrel for its use. Micrel reserves the right to change circuitry and specifications at any time without notification to the customer.

Micrel Products are not designed or authorized for use as components in life support appliances, devices or systems where malfunction of a product can reasonably be expected to result in personal injury. Life support devices or systems are devices or systems that (a) are intended for surgical implant into the body or (b) support or sustain life, and whose failure to perform can be reasonably expected to result in a significant injury to the user. A Purchaser's use or sale of Micrel Products for use in life support appliances, devices or systems is at Purchaser's own risk and Purchaser agrees to fully indemnify Micrel for any damages resulting from such use or sale.

© 2006 Micrel, Incorporated.