

PART NUMBER	ENGINEERING NUMBER	DIMENSION "A"	BUSBAR OPTION	DAMBAR OPTION	PLATING	
					CONTACT AREA	TAIL AREA
051-24-2021	70984-1001	N/A	NO	NO	.000030/(0.00076) MINIMUM GOLD OVER A NICKEL UNDERPLATE	.000100/(0.00254) MINIMUM TIN OVER A NICKEL UNDERPLATE
051-24-2022	70984-1002	.130±.010	NO	NO	.000030/(0.00076) MINIMUM GOLD OVER A NICKEL UNDERPLATE	.000100/(0.00254) MINIMUM TIN OVER A NICKEL UNDERPLATE
70984-1007		N/A	YES	NO	.000030/(0.00076) MINIMUM GOLD OVER A NICKEL UNDERPLATE	.000050/(0.00127) MINIMUM NICKEL
70984-1010		N/A	YES	NO	.000030/(0.00076) MINIMUM GOLD OVER A NICKEL UNDERPLATE	.000200/(0.00508) MINIMUM TIN OVER A NICKEL UNDERPLATE
70984-1005		N/A	YES	YES	.000030/(0.00076) MINIMUM GOLD OVER A NICKEL UNDERPLATE	.000050/(0.00127) MINIMUM NICKEL
70984-1008		N/A	YES	YES	.000030/(0.00076) MINIMUM GOLD OVER A NICKEL UNDERPLATE	.000200/(0.00508) MINIMUM TIN OVER A NICKEL UNDERPLATE
70984-1013		.130±.010	YES	NO	.000030/(0.00076) MINIMUM GOLD OVER A NICKEL UNDERPLATE	.000050/(0.00127) MINIMUM NICKEL

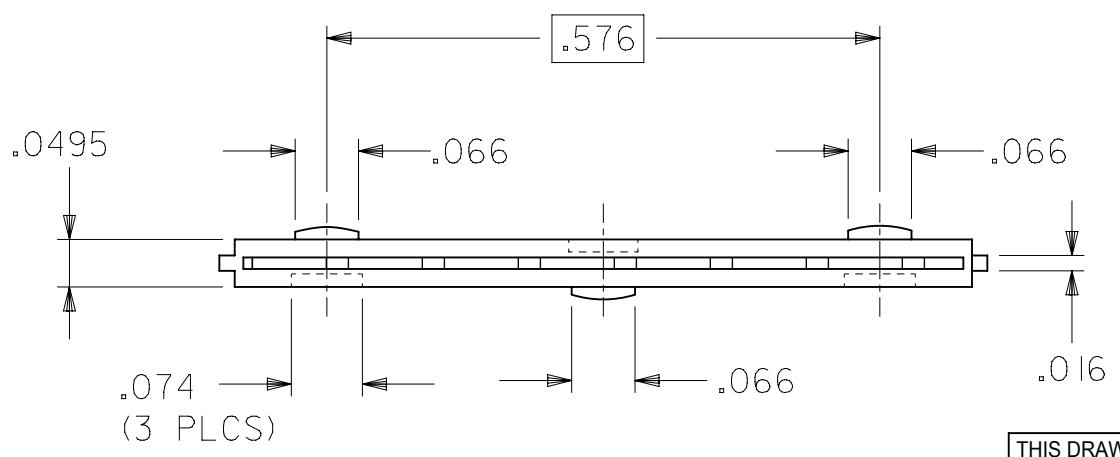
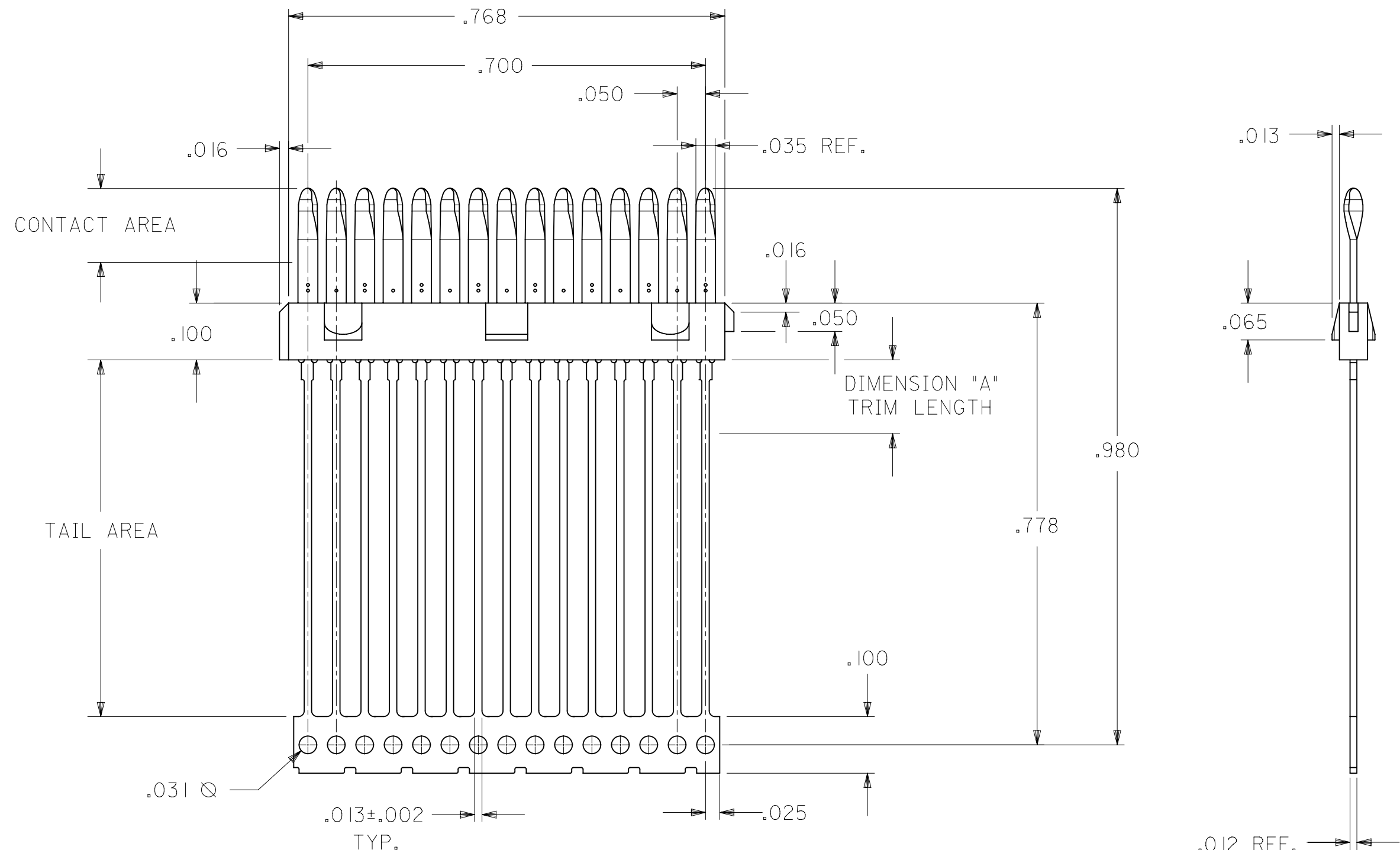
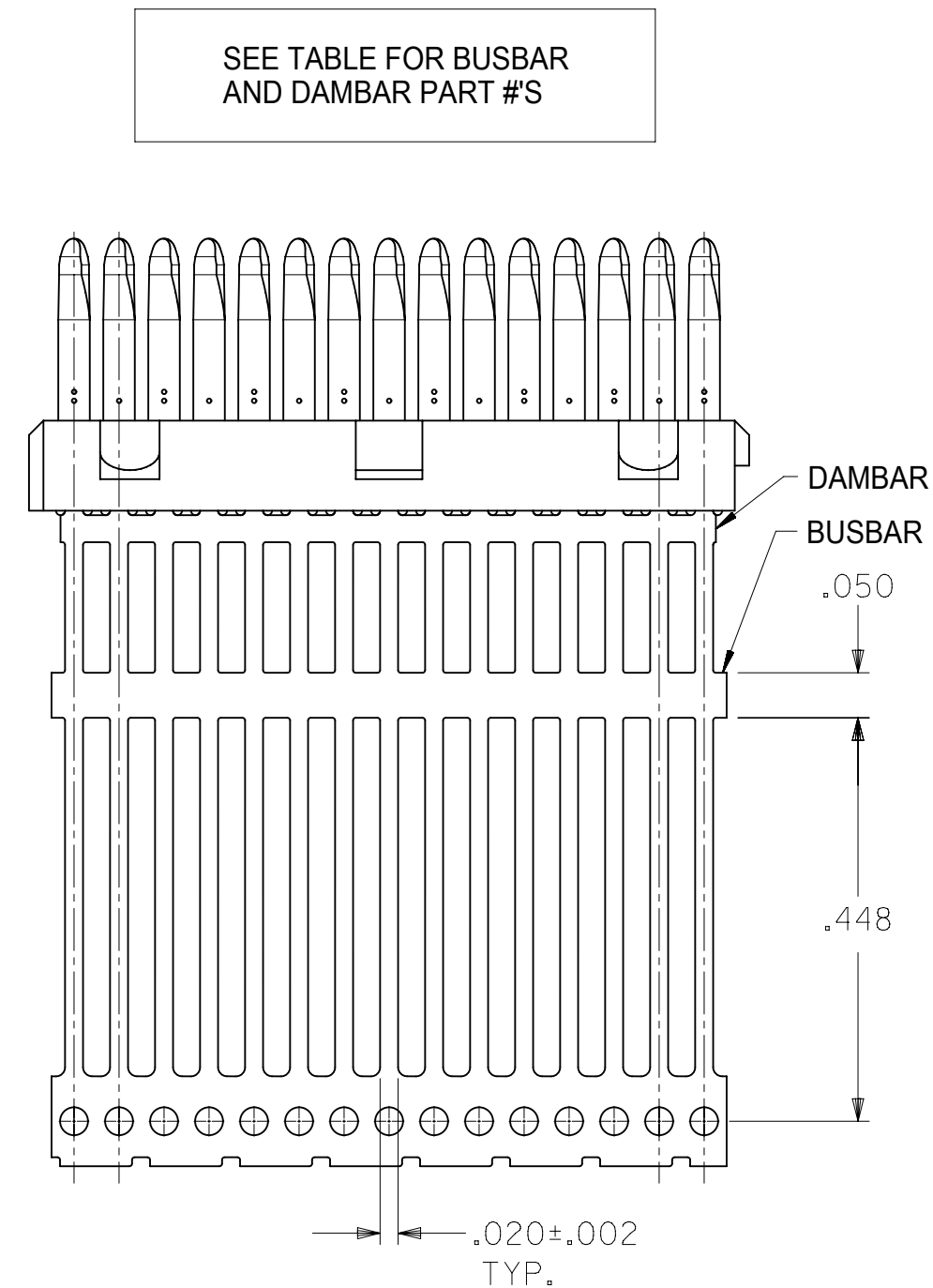

- NOTES:
- 1) MATERIALS: INSULATOR - GLASS FILLED LIQUID CRYSTAL POLYMER (LCP), UL 94V-0, COLOR - BLACK
TERMINAL - PHOSPHOR BRONZE, .012 THICK.
 - 2) FOR PART NUMBERS AND PLATING OPTIONS, SEE CHART.
 - 3) PARTS CONFORM TO PRODUCT SPECIFICATION PS-70928.
 - 4) PACKAGED PER PK-70873-0335, PACKAGE PER PK-70873-0351.
 - 5) PART COMPLIES WITH CLASS C OF COSMETIC SPECIFICATION PS-45499-002.

THIS DRAWING CONTAINS INFORMATION THAT IS PROPRIETARY TO MOLEX ELECTRONIC TECHNOLOGIES, LLC AND SHOULD NOT BE USED WITHOUT WRITTEN PERMISSION

DIMENSION UNITS	SCALE	CURRENT REV DESC:	
INCH	NTS		
GENERAL TOLERANCES (UNLESS SPECIFIED)		EC NO: 620216	
4 PLACES	± .01	DRWN: AKUMAR19	2018/04/27
3 PLACES	± .01	CHK'D: GGA	2019/07/09
2 PLACES	± .01	APPR: GGA	2019/07/09
1 PLACE	± .01	INITIAL REVISION:	
0 PLACES	± .01	DRWN: SCHMIDGALL	1993/12/07
ANGULAR TOL	± 0.5°	APPR: CAB	1993/12/07
DRAFT WHERE APPLICABLE MUST REMAIN WITHIN DIMENSIONS		THIRD ANGLE PROJECTION	DRAWING SERIES
			C-SIZE 70984

15 CKT LFH PLUG INSERT MOLDED CONTACT ASSEMBLY - MANUFACTURING			
PRODUCT CUSTOMER DRAWING			
DOCUMENT NUMBER	DOC TYPE	DOC PART	REVISION
SDA-70984-100	PSD	001	J
MATERIAL NUMBER	CUSTOMER	SHEET NUMBER	
SEE TABLE	GENERAL MARKET	1 OF 1	

PART NUMBER	ENGINEERING NUMBER	DIMENSION "A"	BUSBAR OPTION	PLATING	
				CONTACT AREA	TAIL AREA
051-24-2021	70984-1001	N/A	NO	.000030/(0.00076) MINIMUM GOLD OVER A NICKEL UNDERPLATE	.000100/(0.00254) MINIMUM TIN OVER A NICKEL UNDERPLATE
051-24-2022	70984-1002	.130±.010	NO	.000030/(0.00076) MINIMUM GOLD OVER A NICKEL UNDERPLATE	.000100/(0.00254) MINIMUM TIN OVER A NICKEL UNDERPLATE
70984-1007		N/A	YES	.000030/(0.00076) MINIMUM GOLD OVER A NICKEL UNDERPLATE	.000050/(0.00127) MINIMUM NICKEL
70984-1010		N/A	YES	.000030/(0.00076) MINIMUM GOLD OVER A NICKEL UNDERPLATE	.000200/(0.00508) MINIMUM TIN OVER A NICKEL UNDERPLATE
70984-1014		.130±.010	NO	GOLD FLASH OVER A NICKEL UNDERPLATE	

BUSBAR OPTION
(SEE CHART FOR PART #'S)

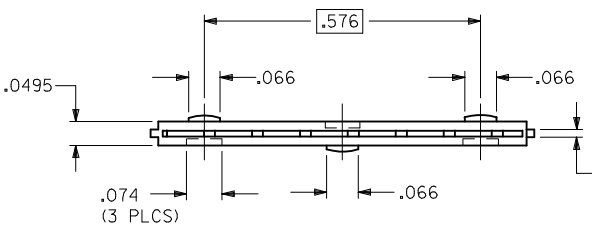
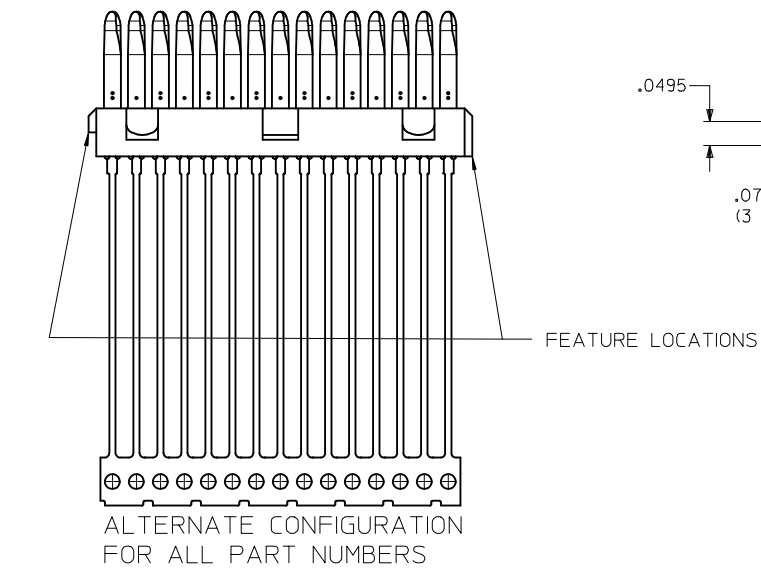
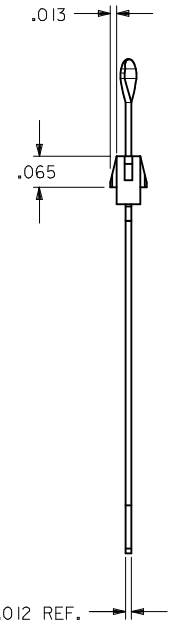
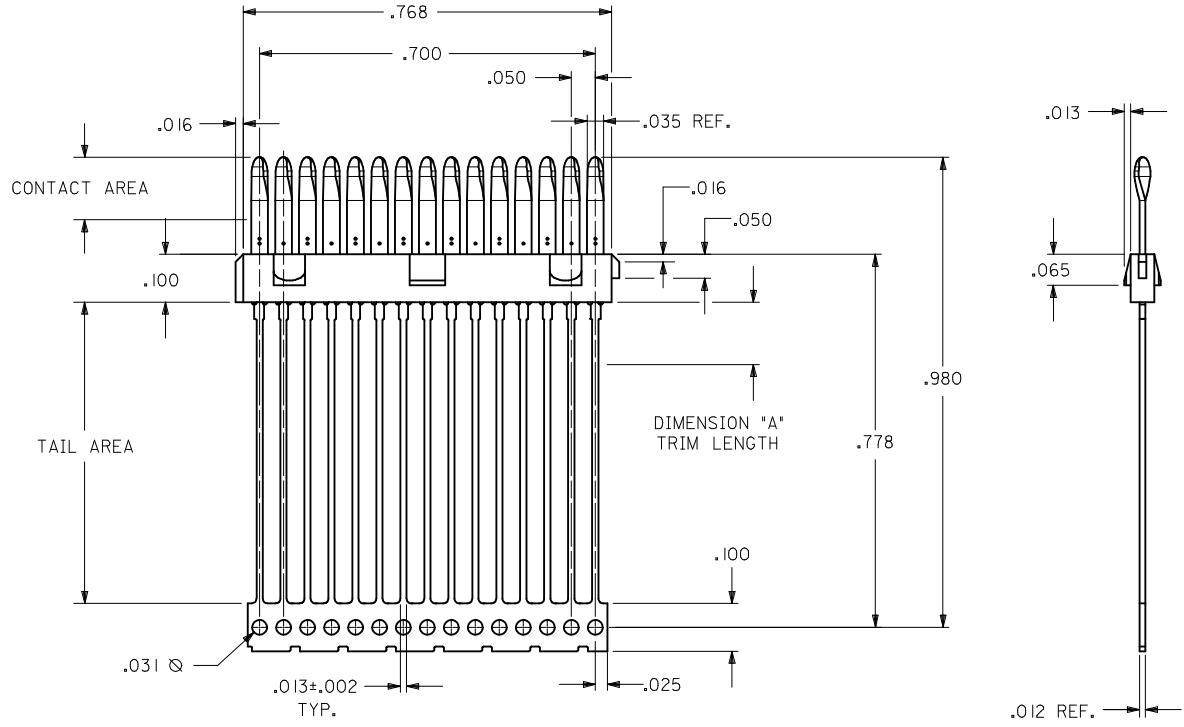
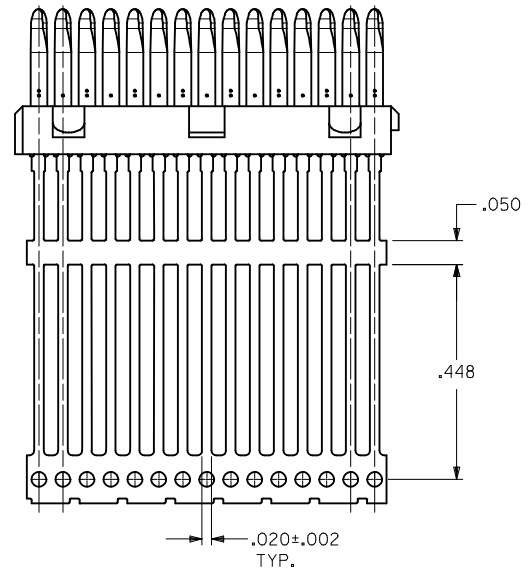

- NOTES
- MATERIALS:
INSULATOR: GLASS FILLED LIQUID CRYSTAL POLYMER (LCP), UL 94V-0, COLOR: BLACK.
TERMINAL: PHOSPHOR BRONZE, .012 THICK.
PLATING: SEE CHART
 - FOR PART NUMBERS AND PLATING OPTIONS, SEE CHART.
 - PARTS CONFORM TO PRODUCT SPECIFICATION PS-70928.
 - PACKAGED PER SPECIFICATION PK-70873-0335 APPLIES.

ADD ALT. CONFIGURATION EC NO: UCP2013-5106 DRWING: DMORGAN 2013/05/24 CHKD: MPOFF 2013/05/24 APPR: SWILLER 2013/06/03 REV:	QUALITY SYMBOLS 	GENERAL TOLERANCES (UNLESS SPECIFIED)		DIMENSION STYLE INCH ONLY	SCALE 5:1	DESIGN UNITS INCH	THIRD ANGLE PROJECTION
		4 PLACES ± --- ± --- 3 PLACES ± --- ± .010 2 PLACES ± --- ± --- 1 PLACE ± --- ± --- 0 PLACE ± --- ± ---	mm INCH ± --- ± --- ± .010 ± --- ± --- ± --- ± --- ± --- ± --- ± ---	DRAWN BY DMORGAN	DATE 2013/05/24	TITLE LFH INSERT MOLDED STICK 15 CIRCUIT MALE (SALES DETAIL)	MATERIAL NO. SEE TABLE
ANGLUAR ±1/2° DRAFT WHERE APPLICABLE MUST REMAIN WITHIN DIMENSIONS		THIS DRAWING CONTAINS INFORMATION THAT IS PROPRIETARY TO MOLEX INCORPORATED AND SHOULD NOT BE USED WITHOUT WRITTEN PERMISSION					