



SEP8736-002

SEP Series AlGaAs Infrared Emitting Diode, Side-looking Plastic Package

Representative photograph, actual product appearance may vary.

Due to regional agency approval requirements, some products may not be available in your area. Please contact your regional Honeywell office regarding your product of choice.

Features

- Side-looking plastic package
- 10 ° (nominal) beam angle
- 880 nm wavelength
- Enhanced coupling distance
- Mechanically and spectrally matched to SDP8436 phototransistor

Description

The SEP8736 is an aluminum gallium arsenide infrared emitting diode molded in a side-emitting smoke gray plastic package. The body and integral lens design combines the mounting advantage of a side-emitting package with the narrow emission pattern of a T-1 style device. The SEP8736 IRED is designed for those applications which require longer coupling distances than standard side-emitting devices can provide, such as touch screens. The IRED is also especially well suited to applications in which adjacent channel crosstalk could be a problem.



SEP8736-002

SEP Series AlGaAs Infrared Emitting Diode, Side-looking Plastic Package

Product Specifications	
Product Type	IR Component
Power Output	1.2 - 3.0 mW/cm ²
Beam Angle (Degree)	10
Package Style	Side-Emitting
Package Components	Plastic
Forward Current	20 mA
Continuous Forward Current	50 mA
Forward Voltage	1.7 V
Reverse Breakdown Voltage	3 V

Output Wavelength	880 nm
Spectral Bandwidth	80 nm
Spectral Shift With Temperature	0.2 nm/°C
Rise and Fall Time	0.7 μs
Power Dissipation	100 mW
Operating Temperature Range	-40 °C to 85 °C [-40 °F to 185 °F]
Availability	Global
Product Name	Infrared Emitting Diode

Honeywell

SEP8736-002

SEP Series AlGaAs Infrared Emitting Diode, Side-looking Plastic Package

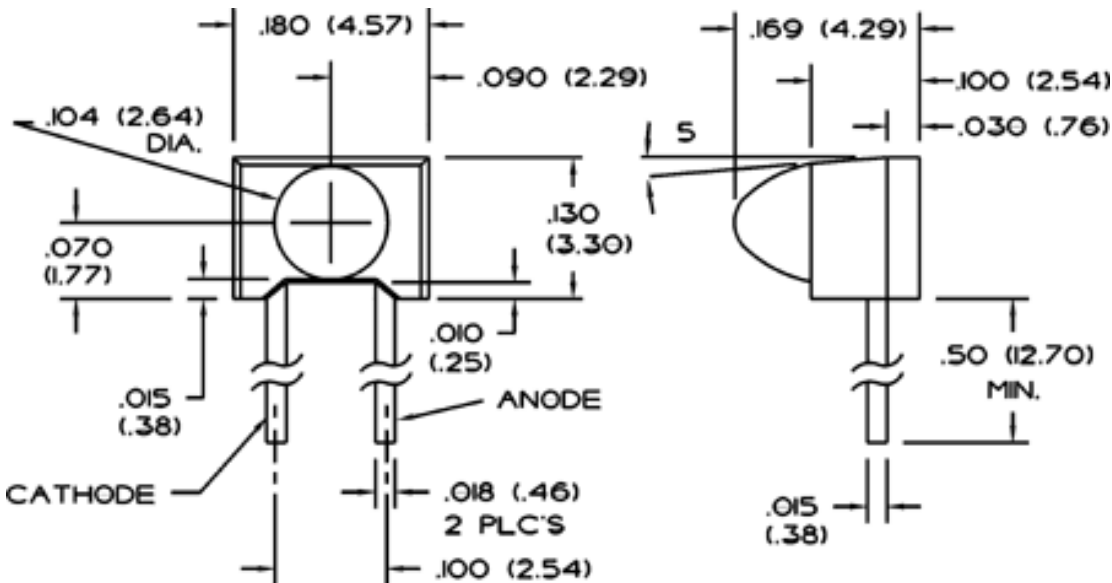

Honeywell

SEP8736-002

SEP Series AlGaAs Infrared Emitting Diode, Side-looking Plastic Package

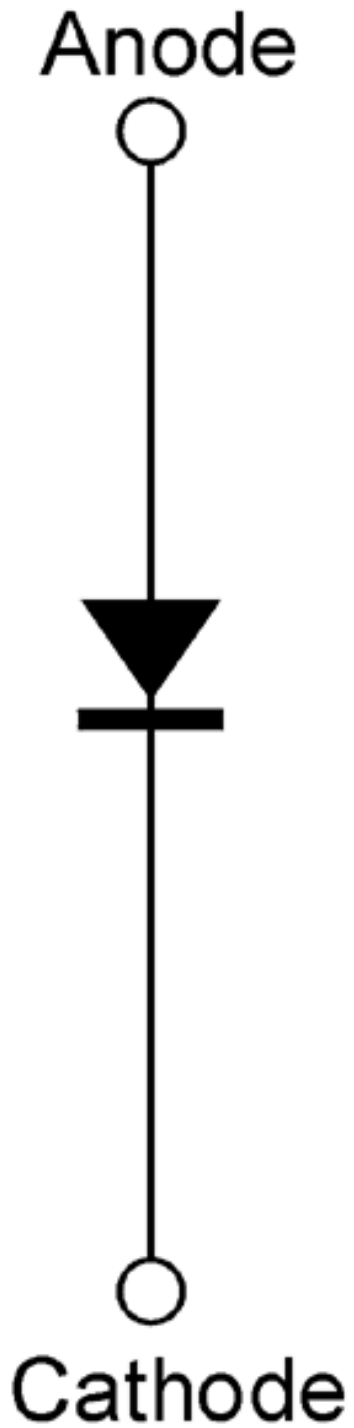

Honeywell

SEP8736-002

SEP Series AlGaAs Infrared Emitting Diode, Side-looking Plastic Package

 WARNING

PERSONAL INJURY

DO NOT USE these products as safety or emergency stop devices, or in any other application where failure of the product could result in personal injury.

Failure to comply with these instructions could result in death or serious injury.

 WARNING

MI SUSE OF DOCUMENTATION

- The information presented in this product sheet (or catalog) is for reference only. DO NOT USE this document as product installation information.
- Complete installation, operation and maintenance information is provided in the instructions supplied with each product.

Failure to comply with these instructions could result in death or serious injury.

© Copyright Honeywell Inc.1998-2004 All rights reserved.