

FEATURES

- Single/Dual Supply Operation: 1.6 V to 36 V, ± 0.8 V to ± 18 V
- True Single-Supply Operation; Input and Output Voltage Ranges Include Ground
- Low Supply Current: 20 μ A Max
- High Output Drive: 5 mA Min
- Low Input Offset Voltage: 150 μ V Max
- High Open-Loop Gain: 700 V/mV Min
- Outstanding PSRR: 5.6 μ V/V Max
- Standard 741 Pinout with Nulling to V-

PIN CONNECTIONS

8-Lead Epoxy Mini-DIP
(P-Suffix)

8-Lead SO
(S-Suffix)

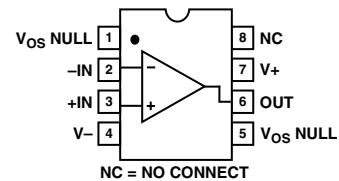

GENERAL DESCRIPTION

The OP90 is a high performance, micropower op amp that operates from a single supply of 1.6 V to 36 V or from dual supplies of ± 0.8 V to ± 18 V. The input voltage range includes the negative rail allowing the OP90 to accommodate input signals down to ground in a single-supply operation. The OP90's output swing also includes a ground when operating from a single-supply, enabling "zero-in, zero-out" operation.

The OP90 draws less than 20 μ A of quiescent supply current, while able to deliver over 5 mA of output current to a load. The input offset voltage is below 150 μ V eliminating the need for

external nulling. Gain exceeds 700,000 and common-mode rejection is better than 100 dB. The power supply rejection ratio of under 5.6 μ V/V minimizes offset voltage changes experienced in battery-powered systems.

The low offset voltage and high gain offered by the OP90 bring precision performance to micropower applications. The minimal voltage and current requirements of the OP90 suit it for battery and solar powered applications, such as portable instruments, remote sensors, and satellites.

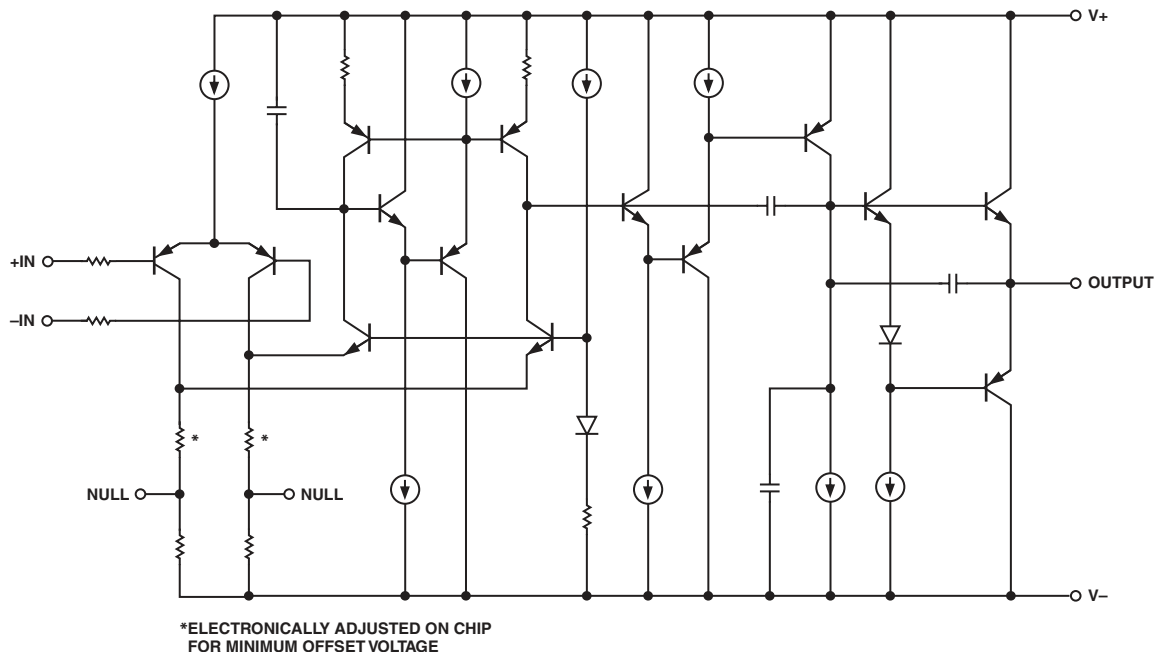

Figure 1. Simplified Schematic

REV. C

Information furnished by Analog Devices is believed to be accurate and reliable. However, no responsibility is assumed by Analog Devices for its use, nor for any infringements of patents or other rights of third parties that may result from its use. No license is granted by implication or otherwise under any patent or patent rights of Analog Devices.

OP90

SPECIFICATIONS

ELECTRICAL CHARACTERISTICS

($V_S = \pm 1.5\text{ V}$ to $\pm 15\text{ V}$, $T_A = 25^\circ\text{C}$, unless otherwise noted.)

Parameter	Symbol	Conditions	OP90G			Unit
			Min	Typ	Max	
INPUT OFFSET VOLTAGE	V_{OS}			125	450	μV
INPUT OFFSET CURRENT	I_{OS}	$V_{CM} = 0\text{ V}$		0.4	5	nA
INPUT BIAS CURRENT	I_B	$V_{CM} = 0\text{ V}$		4.0	25	nA
LARGE-SIGNAL VOLTAGE GAIN	A_{VO}	$V_S = \pm 15\text{ V}$, $V_O = \pm 10\text{ V}$ $R_L = 100\text{ k}\Omega$	400	800		V/mV
	A_{VO}	$R_L = 10\text{ k}\Omega$	200	400		V/mV
	A_{VO}	$R_L = 2\text{ k}\Omega$ $V_+ = 5\text{ V}$, $V_- = 0\text{ V}$, $1\text{ V} < V_O < 4\text{ V}$	100	200		V/mV
	A_{VO}	$R_L = 100\text{ k}\Omega$	100	250		V/mV
	A_{VO}	$R_L = 10\text{ k}\Omega$	70	140		V/mV
INPUT VOLTAGE RANGE ¹	IVR	$V_+ = 5\text{ V}$, $V_- = 0\text{ V}$	0/4			V
		$V_S = \pm 15\text{ V}$	-15/13.5			V
OUTPUT VOLTAGE SWING	V_O	$V_S = \pm 15\text{ V}$ $R_L = 10\text{ k}\Omega$	± 14	± 14.2		V
		$R_L = 2\text{ k}\Omega$	± 11	± 12		V
	V_{OH}	$V_+ = 5\text{ V}$, $V_- = 0\text{ V}$ $R_L = 2\text{ k}\Omega$	4.0	4.2		V
	V_{OL}	$V_+ = 5\text{ V}$, $V_- = 0\text{ V}$				
		$R_L = 10\text{ k}\Omega$		100	500	μV
COMMON-MODE REJECTION	CMR	$V_+ = 5\text{ V}$, $V_- = 0\text{ V}$, $0\text{ V} < V_{CM} < 4\text{ V}$	80	100		dB
	CMR	$V_S = \pm 15\text{ V}$, $-15\text{ V} < V_{CM} < 13.5\text{ V}$	90	120		dB
POWER SUPPLY REJECTION RATIO	PSRR			3.2	10	$\mu\text{V/V}$
SLEW RATE	SR	$V_S = \pm 15\text{ V}$	5	12		V/ms
SUPPLY CURRENT	I_{SY}	$V_S = \pm 1.5\text{ V}$		9	15	μA
	I_{SY}	$V_S = \pm 15\text{ V}$		14	20	μA
CAPACITIVE LOAD STABILITY ²		$A_V = 1$ No Oscillations	250	650		pF
INPUT NOISE VOLTAGE	$e_{n\text{ p-p}}$	$f_O = 0.1\text{ Hz}$ to 10 Hz $V_S = \pm 15\text{ V}$		3		$\mu\text{V p-p}$
INPUT RESISTANCE DIFFERENTIAL MODE	R_{IN}	$V_S = \pm 15\text{ V}$		30		M Ω
INPUT RESISTANCE COMMON-MODE	R_{INCM}	$V_S = \pm 15\text{ V}$		20		G Ω

NOTES

¹Guaranteed by CMR test.

²Guaranteed but not 100% tested.

Specifications subject to change without notice.

ELECTRICAL CHARACTERISTICS ($V_S = \pm 1.5\text{ V to } \pm 15\text{ V}$, $-55^\circ\text{C} \leq T_A \leq +125^\circ\text{C}$, unless otherwise noted.)

Parameter	Symbol	Conditions	Min	Typ	Max	Unit	
INPUT OFFSET VOLTAGE	V_{OS}			80	400	μV	
AVERAGE INPUT OFFSET VOLTAGE DRIFT	TCV_{OS}			0.3	2.5	$\mu\text{V}/^\circ\text{C}$	
INPUT OFFSET CURRENT	I_{OS}	$V_{CM} = 0\text{ V}$		1.5	5	nA	
INPUT BIAS CURRENT	I_B	$V_{CM} = 0\text{ V}$		4.0	20	nA	
LARGE-SIGNAL VOLTAGE GAIN	A_{VO}	$V_S = \pm 15\text{ V}$, $V_O = \pm 10\text{ V}$ $R_L = 100\text{ k}\Omega$ $R_L = 10\text{ k}\Omega$ $R_L = 2\text{ k}\Omega$	225	400		V/mV	
			125	240		V/mV	
			50	110		V/mV	
	A_{VO}	$V_+ = 5\text{ V}$, $V_- = 0\text{ V}$, $1\text{ V} < V_O < 4\text{ V}$ $R_L = 100\text{ k}\Omega$ $R_L = 10\text{ k}\Omega$	100	200		V/mV	
			50	110		V/mV	
INPUT VOLTAGE RANGE*	IVR	$V_+ = 5\text{ V}$, $V_- = 0\text{ V}$ $V_S = \pm 15\text{ V}$	0/3.5 -15/13.5			V V	
OUTPUT VOLTAGE SWING	V_O	$V_S = \pm 15\text{ V}$ $R_L = 10\text{ k}\Omega$ $R_L = 2\text{ k}\Omega$	± 13.5 ± 10.5	± 13.7 ± 11.5		V V	
	V_{OH}	$V_+ = 5\text{ V}$, $V_- = 0\text{ V}$ $R_L = 2\text{ k}\Omega$	3.9	4.1		V	
	V_{OL}	$V_+ = 5\text{ V}$, $V_- = 0\text{ V}$ $R_L = 10\text{ k}\Omega$			100	500	μV
COMMON-MODE REJECTION	CMR	$V_+ = 5\text{ V}$, $V_- = 0\text{ V}$, $0\text{ V} < V_{CM} < 3.5\text{ V}$ $V_S = \pm 15\text{ V}$, $15\text{ V} < V_{CM} < 13.5\text{ V}$	85	105		dB	
			95	115		dB	
POWER SUPPLY REJECTION RATIO	PSRR			3.2	10	$\mu\text{V}/\text{V}$	
SUPPLY CURRENT	I_{SY}	$V_S = \pm 1.5\text{ V}$		15	25	μA	
		$V_S = \pm 15\text{ V}$		19	30	μA	

NOTE

*Guaranteed by CMR test.

OP90

ELECTRICAL CHARACTERISTICS

($V_S = \pm 1.5\text{ V}$ to $\pm 15\text{ V}$, $-40^\circ\text{C} \leq T_A \leq +85^\circ\text{C}$ for OP90G, unless otherwise noted.)

Parameter	Symbol	Conditions	OP90G			Unit	
			Min	Typ	Max		
INPUT OFFSET VOLTAGE	V_{OS}			180	675	μV	
AVERAGE INPUT OFFSET VOLTAGE DRIFT	TCV_{OS}			1.2	5	$\mu\text{V}/^\circ\text{C}$	
INPUT OFFSET CURRENT	I_{OS}	$V_{CM} = 0\text{ V}$		1.3	7	nA	
INPUT BIAS CURRENT	I_B	$V_{CM} = 0\text{ V}$		4.0	25	nA	
LARGE-SIGNAL VOLTAGE GAIN	A_{VO}	$V_S = \pm 15\text{ V}$, $V_O = \pm 10\text{ V}$ $R_L = 100\text{ k}\Omega$	300	600		V/mV	
		$R_L = 10\text{ k}\Omega$	150	250		V/mV	
		$R_L = 2\text{ k}\Omega$	75	125		V/mV	
	A_{VO}	$V_+ = 5\text{ V}$, $V_- = 0\text{ V}$, $1\text{ V} < V_O < 4\text{ V}$ $R_L = 100\text{ k}\Omega$	80	160		V/mV	
		$R_L = 10\text{ k}\Omega$	40	90		V/mV	
INPUT VOLTAGE RANGE*	IVR	$V_+ = 5\text{ V}$, $V_- = 0\text{ V}$	0/3.5			V	
		$V_S = \pm 15\text{ V}$	-15/13.5			V	
OUTPUT VOLTAGE SWING	V_O	$V_S = \pm 15\text{ V}$ $R_L = 10\text{ k}\Omega$	± 13.5		± 14	V	
		$R_L = 2\text{ k}\Omega$	± 10.5		± 11.8	V	
	V_{OH}	$V_+ = 5\text{ V}$, $V_- = 0\text{ V}$ $R_L = 2\text{ k}\Omega$	3.9	4.1		V	
	V_{OL}	$V_+ = 5\text{ V}$, $V_- = 0\text{ V}$ $R_L = 10\text{ k}\Omega$			100	500	μV
	COMMON-MODE REJECTION	CMR	$V_+ = 5\text{ V}$, $V_- = 0\text{ V}$, $0\text{ V} < V_{CM} < 3.5\text{ V}$	80	100		dB
$V_S = \pm 15\text{ V}$, $-15\text{ V} < V_{CM} < 13.5\text{ V}$			90	110		dB	
POWER SUPPLY REJECTION RATIO	PSRR			5.6	17.8	$\mu\text{V}/\text{V}$	
SUPPLY CURRENT	I_{SY}	$V_S = \pm 1.5\text{ V}$		12	25	μA	
		$V_S = \pm 15\text{ V}$		16	30	μA	

NOTE

*Guaranteed by CMR test.

ABSOLUTE MAXIMUM RATINGS¹

Supply Voltage ±18 V
 Differential Input Voltage . . . [(V-) - 20 V] to [(V+) + 20 V]
 Common-Mode Input Voltage
 [(V-) - 20 V] to [(V+) + 20 V]

Output Short-Circuit Duration Indefinite
 Storage Temperature Range
 S Package -65°C to +150°C
 P Package -65°C to +150°C
 Operating Temperature Range

OP90G -40°C to +85°C
 Junction Temperature (T_J) -65°C to +150°C
 Lead Temperature (Soldering 60 sec) 300°C

Package Type	θ_{JA}^2	θ_{JC}	Unit
8-Lead Plastic DIP (P)	103	43	°C/W
8-Lead SO (S)	158	43	°C/W

NOTES

¹Absolute Maximum Ratings apply to packaged parts, unless otherwise noted.

² θ_{JA} is specified for worst-case mounting conditions; i.e., θ_{JA} is specified for device in socket for P-DIP; θ_{JA} is specified for devices soldered to printed circuit board for SO package.

CAUTION

ESD (electrostatic discharge) sensitive device. Electrostatic charges as high as 4000 V readily accumulate on the human body and test equipment and can discharge without detection. Although the OP90 features proprietary ESD protection circuitry, permanent damage may occur on devices subjected to high-energy electrostatic discharges. Therefore, proper ESD precautions are recommended to avoid performance degradation or loss of functionality.



OP90 – Typical Performance Characteristics

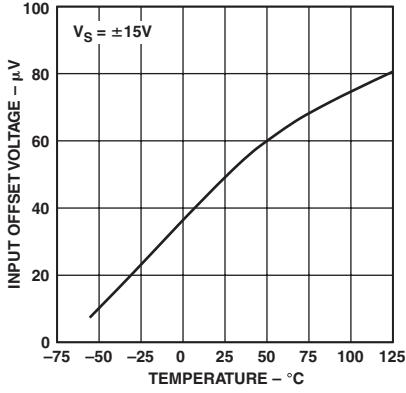

TPC 1. Input Offset Voltage vs. Temperature

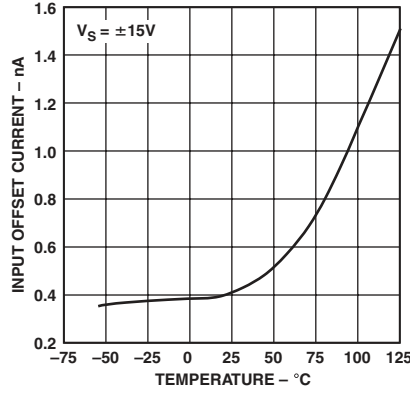

TPC 2. Input Offset Current vs. Temperature

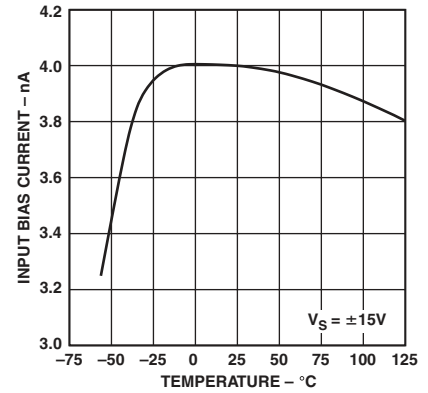

TPC 3. Input Bias Current vs. Temperature

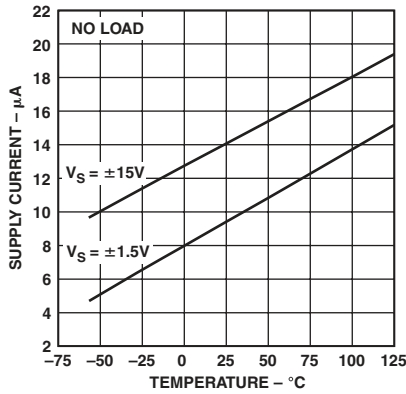

TPC 4. Supply Current vs. Temperature

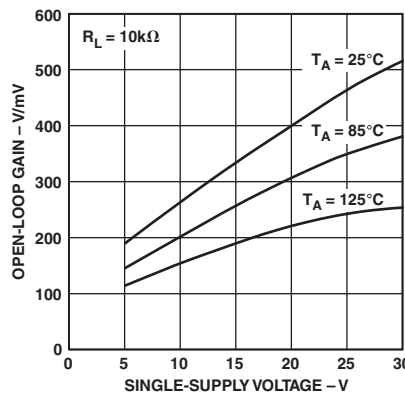

TPC 5. Open-Loop Gain vs. Single-Supply Voltage

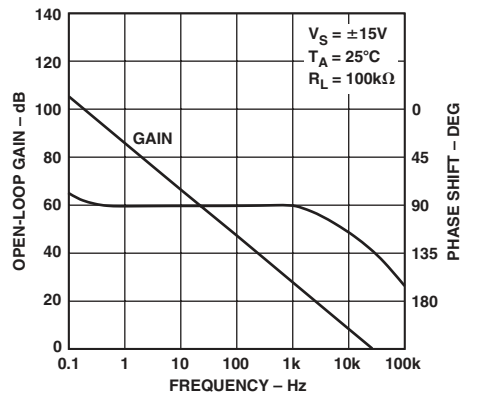

TPC 6. Open-Loop Gain and Phase Shift vs. Frequency

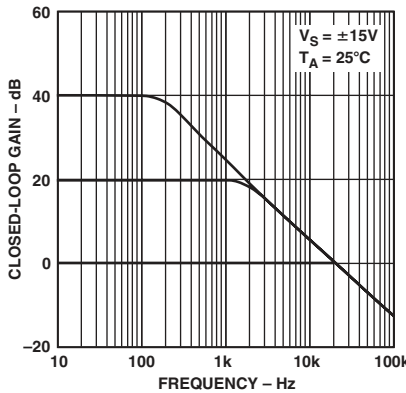

TPC 7. Closed-Loop Gain vs. Frequency

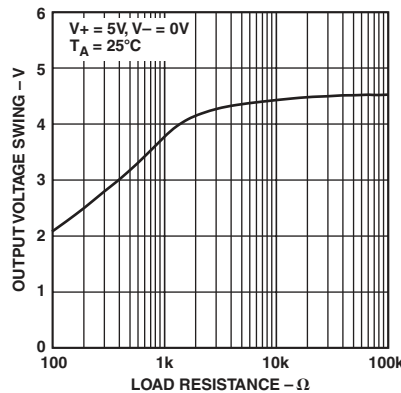

TPC 8. Output Voltage Swing vs. Load Resistance

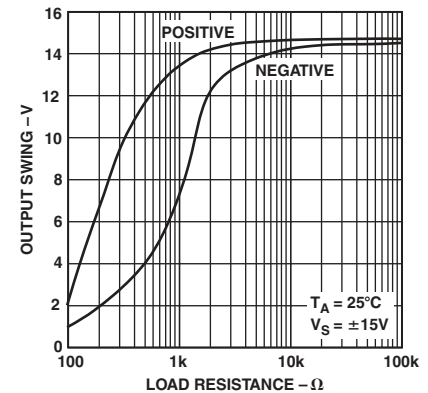

TPC 9. Output Voltage Swing vs. Load Resistance

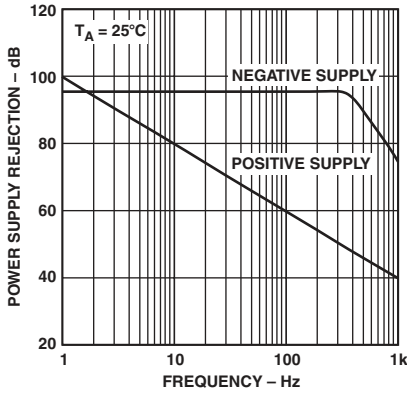

TPC 10. Power Supply Rejection vs. Frequency

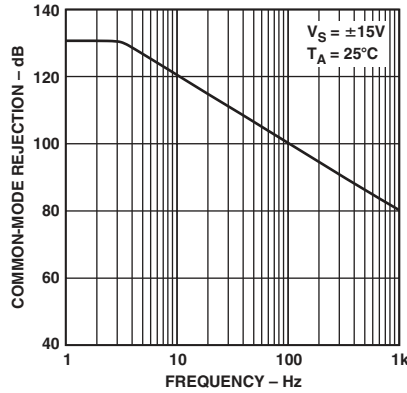

TPC 11. Common-Mode Rejection vs. Frequency

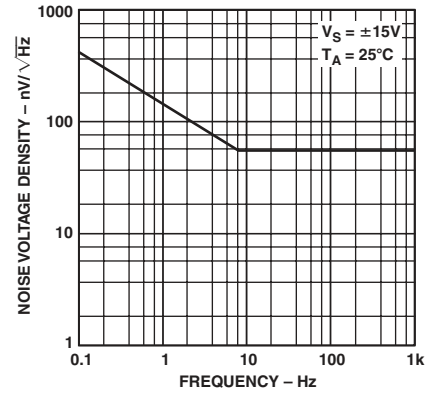

TPC 12. Noise Voltage Density vs. Frequency

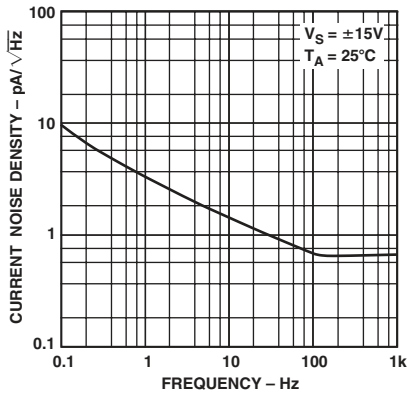

TPC 13. Current Noise Density vs. Frequency

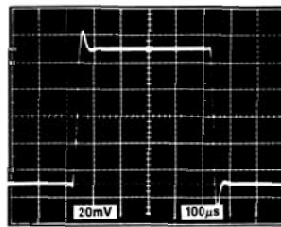

TA = 25°C
VS = ±15V
AV = +1
RL = 10kΩ
CL = 500pF

TPC 14. Small-Signal Transient Response

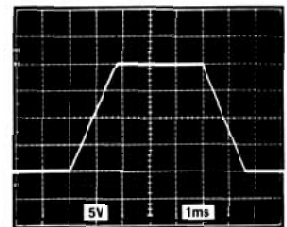

TA = 25°C
VS = ±15V
AV = +1
RL = 10kΩ
CL = 500pF

TPC 15. Large-Signal Transient Response

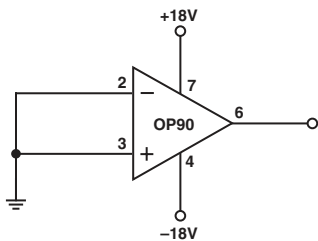

Figure 2. Burn-In Circuit

APPLICATION INFORMATION

Battery-Powered Applications

The OP90 can be operated on a minimum supply voltage of 1.6 V, or with dual supplies ± 0.8 V, and draws only 14 pA of supply current. In many battery-powered circuits, the OP90 can be continuously operated for thousands of hours before requiring battery replacement, reducing equipment down time and operating cost.

High-performance portable equipment and instruments frequently use lithium cells because of their long shelf-life, light weight, and high-energy density relative to older primary cells. Most lithium cells have a nominal output voltage of 3 V and are noted for a flat discharge characteristic. The low-supply voltage requirement of the OP90, combined with the flat discharge characteristic of the lithium cell, indicates that the OP90 can be operated over the entire useful life of the cell. Figure 1 shows the typical discharge characteristic of a 1Ah lithium cell powering an OP90 which, in turn, is driving full output swing into a 100 kΩ load.

OP90

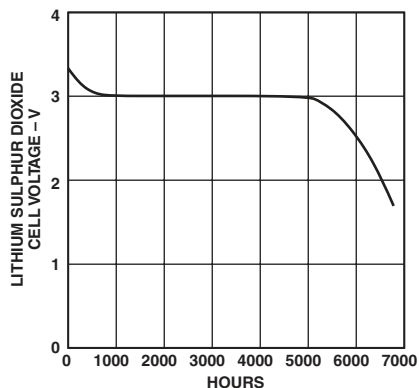

Figure 3. Lithium Sulphur Dioxide Cell Discharge Characteristic with OP90 and 100 kΩ Load

Input Voltage Protection

The OP90 uses a PNP input stage with protection resistors in series with the inverting and noninverting inputs. The high breakdown of the PNP transistors coupled with the protection resistors provides a large amount of input protection, allowing the inputs to be taken 20 V beyond either supply without damaging the amplifier.

Offset Nulling

The offset null circuit of Figure 4 provides 6 mV of offset adjustment range. A 100 kΩ resistor placed in a series with the wiper of the offset null potentiometer, as shown in Figure 5, reduces the offset adjustment range to 400 μV and is recommended for applications requiring high null resolution. Offset nulling does not affect TCV_{OS} performance.

TEST CIRCUITS

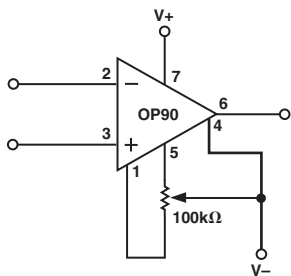

Figure 4. Offset Nulling Circuit

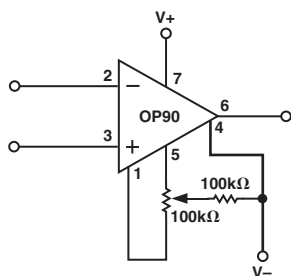

Figure 5. High Resolution Offset Nulling Circuit

Single-Supply Output Voltage Range

In single-supply operation, the OP90's input and output ranges include ground. This allows true "zero-in, zero-out" operation. The output stage provides an active pull-down to around 0.8 V above ground. Below this level, a load resistance of up to 1 MΩ to ground is required to pull the output down to zero.

In the region from ground to 0.8 V, the OP90 has voltage gain equal to the data sheet specification. Output current source capability is maintained over the entire voltage range including ground.

APPLICATIONS

Battery-Powered Voltage Reference

The circuit of Figure 6 is a battery-powered voltage reference that draws only 17 μA of supply current. At this level, two AA cells can power this reference over 18 months. At an output voltage of 1.23 V @ 25°C, drift of the reference is only at 5.5 μV/°C over the industrial temperature range. Load regulation is 85 μV/mA with line regulation at 120 μV/V.

Design of the reference is based on the bandgap technique. Scaling of resistors R1 and R2 produces unequal currents in Q1 and Q2. The resulting V_{BE} mismatch creates a temperature proportional voltage across R3 which, in turn, produces a larger temperature-proportional voltage across R4 and R5. This voltage appears at the output added to the V_{BE} of Q1, which has an opposite temperature coefficient. Adjusting the output to 1.23 V at 25°C produces minimum drift over temperature. Bandgap references can have start-up problems. With no current in R1 and R2, the OP90 is beyond its positive input range limit and has an undefined output state. Shorting Pin 5 (an offset adjust pin) to ground, forces the output high under these conditions and ensures reliable start-up without significantly degrading the OP90's offset drift.

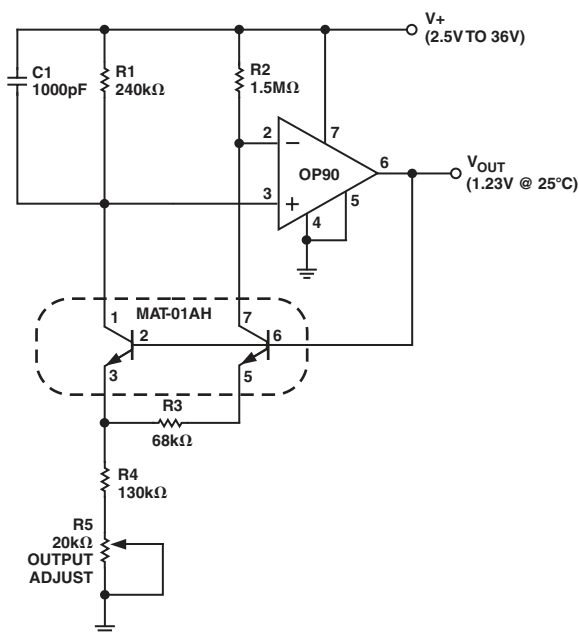

Figure 6. Battery-Powered Voltage Reference

Single Op Amp Full-Wave Rectifier

Figure 7 shows a full-wave rectifier circuit that provides the absolute value of input signals up to ± 2.5 V even though operated from a single 5 V supply. For negative inputs, the amplifier acts as a unity-gain inverter. Positive signals force the op amp output to ground. The 1N914 diode becomes reversed-biased and the signal passes through R1 and R2 to the output. Since output impedance is dependent on input polarity, load impedances cause an asymmetric output. For constant load impedances, this can be corrected by reducing R2. Varying or heavy loads can be buffered by a second OP90. Figure 8 shows the output of the full-wave rectifier with a 4 V_{p-p}, 10 Hz input signal.

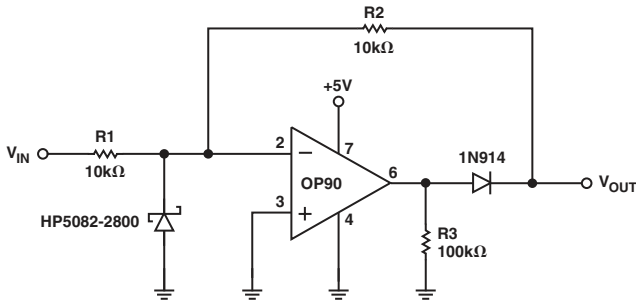

Figure 7. Single Op Amp Full-Wave Rectifier

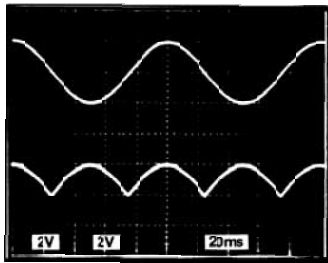

Figure 8. Output of Full-Wave Rectifier with 4 V_{p-p}, 10 Hz Input

2-WIRE 4 mA TO 20 mA CURRENT TRANSMITTER

The current transmitter of Figure 9 provides an output of 4 mA to 20 mA that is linearly proportional to the input voltage. Linearity of the transmitter exceeds 0.004% and line rejection is 0.0005%/volt.

Biasing for the current transmitter is provided by the REF-02EZ. The OP90 regulates the output current to satisfy the current summation at the noninverting node:

$$I_{OUT} = \frac{1}{R6} \left(\frac{V_{IN} R5}{R2} + \frac{5V R5}{R1} \right)$$

For the values shown in Figure 9,

$$I_{OUT} = \left(\frac{16}{100 \Omega} \right) V_{IN} + 4 mA$$

giving a full-scale output of 20 mA with a 100 mV input. Adjustment of R2 will provide an offset trim and adjustment of R1 will provide a gain trim. These trims do not interact since the noninverting input of the OP90 is at virtual ground. The Schottky diode, D1, prevents input voltage spikes from pulling the noninverting input more than 300 mV below the inverting input. Without the diode, such spikes could cause phase reversal of the OP90 and possible latch-up of the transmitter. Compliance of this circuit is from 10 V to 40 V. The voltage reference output can provide up to 2 mA for transducer excitation.

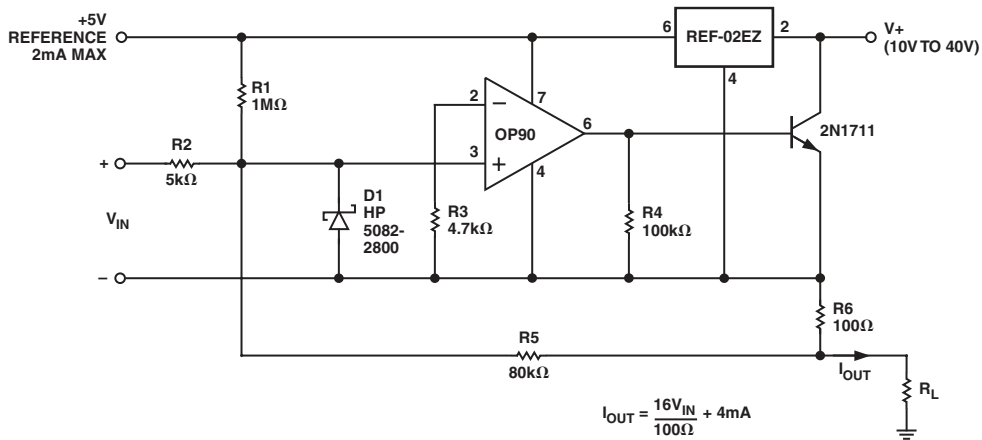

Figure 9. 2-Wire 4 mA to 20mA Transmitter

OP90

Micropower Voltage-Controlled Oscillator

Two OP90s in combination with an inexpensive quad CMOS switch comprise the precision VCO of Figure 10. This circuit provides triangle and square wave outputs and draws only 50 μA from a single 5 V supply. A1 acts as an integrator; S1 switches the charging current symmetrically to yield positive and negative ramps. The integrator is bounded by A2 which acts as a Schmitt trigger with a precise hysteresis of 1.67 V, set by resistors R5, R6, and R7, and associated CMOS switches. The resulting output of A1 is a triangular wave with upper and lower levels of 3.33 V and 1.67 V. The output of A2 is a square wave with almost rail-to-rail swing. With the components shown, frequency of operation is given by the equation:

$$f_{OUT} = V_{CONTROL}(V) \times 10 \text{ Hz} / V$$

but this is easily changed by varying C1. The circuit operates well up to a few hundred hertz.

Micropower Single-Supply Instrumentation Amplifier

The simple instrumentation amplifier of Figure 11 provides over 110 dB of common-mode rejection and draws only 15 μA of supply current. Feedback is to the trim pins rather than to the inverting input. This enables a single amplifier to provide differential to single-ended conversion with excellent common-mode rejection. Distortion of the instrumentation amplifier is that of a differential pair, so the circuit is restricted to high gain applica-

tions. Nonlinearity is less than 0.1% for gains of 500 to 1000 over a 2.5 V output range. Resistors R3 and R4 set the voltage gain and, with the values shown, yield a gain of 1000. Gain tempco of the instrumentation amplifier is only 50 ppm/ $^{\circ}\text{C}$. Offset voltage is under 150 μV with drift below 2 $\mu\text{V}/^{\circ}\text{C}$. The OP90's input and output voltage ranges include the negative rail which allows the instrumentation amplifier to provide true "zero-in, zero-out" operation.

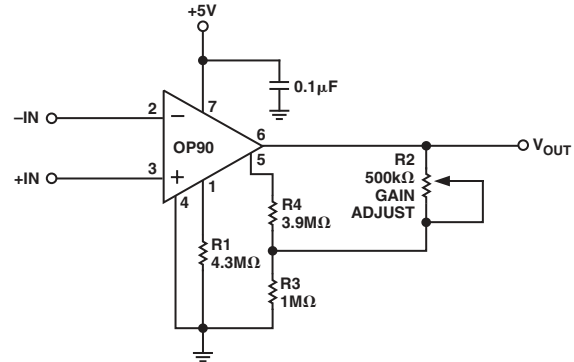

Figure 11. Micropower Single-Supply Instrumentation Amplifier

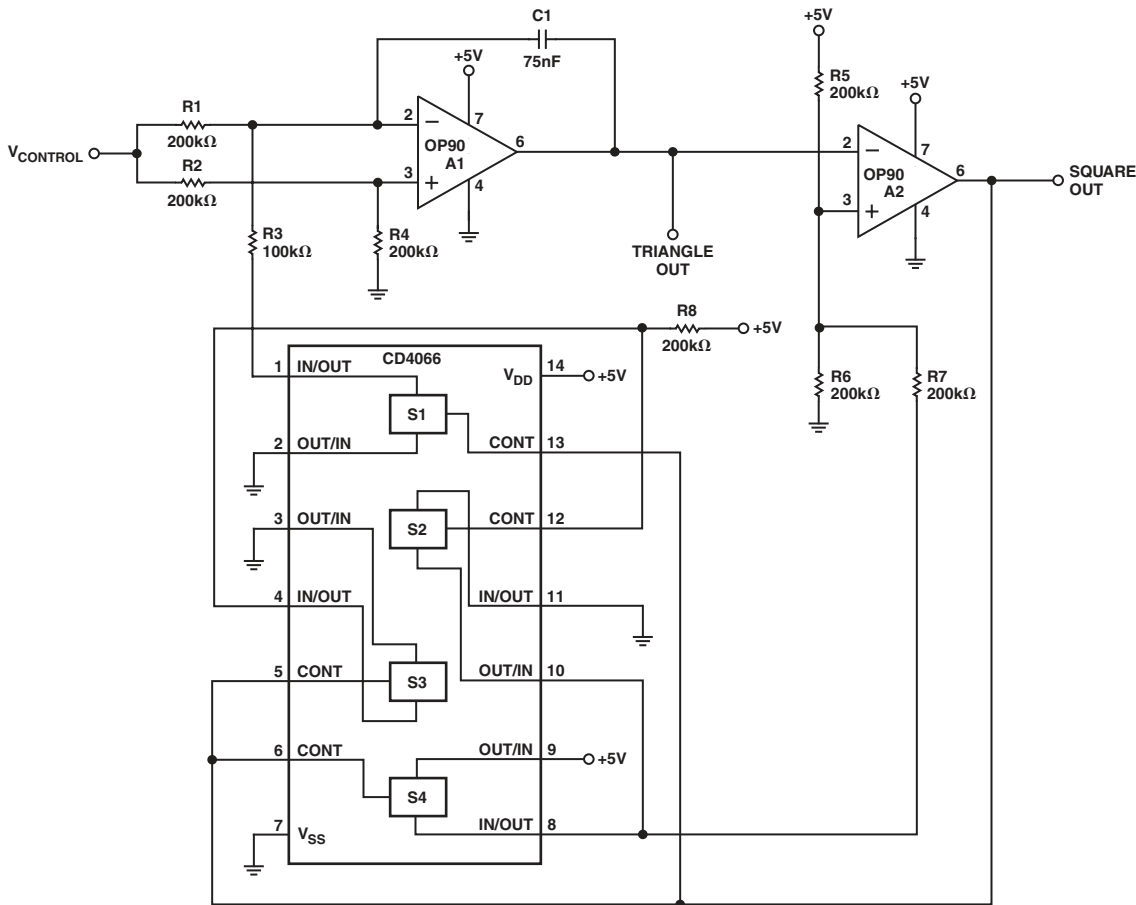

Figure 10. Micropower Voltage Controlled Oscillator

Single-Supply Current Monitor

Current monitoring essentially consists of amplifying the voltage drop across a resistor placed in a series with the current to be measured. The difficulty is that only small voltage drops can be tolerated and with low precision op amps this greatly limits the overall resolution. The single supply current monitor of Figure 12 has a resolution of 10 μA and is capable of monitoring 30 mA of current. This range can be adjusted by changing the current sense resistor R1. When measuring total system current, it may be necessary to include the supply current of the current monitor, which bypasses the current sense resistor, in the final result. This current can be measured and calibrated (together with the residual offset) by adjustment of the offset trim potentiometer, R2. This produces a deliberate offset that is temperature dependent. However, the supply current of the OP90 is also proportional to temperature and the two effects tend to track. Current in R4 and R5, which also bypasses R1, can be accounted for by a gain trim.

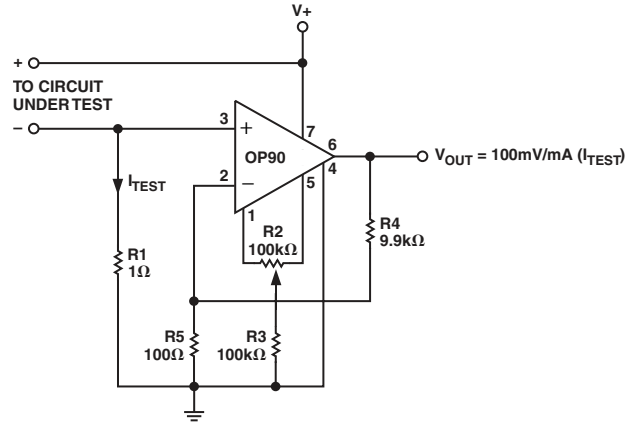
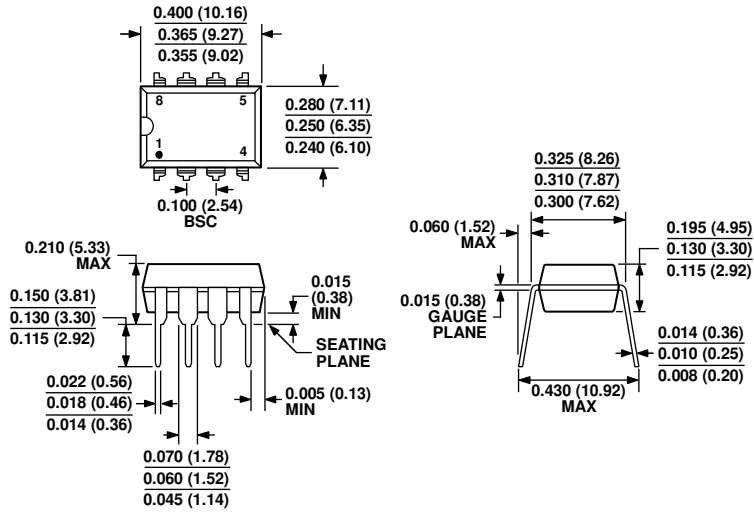

Figure 12. Single-Supply Current Monitor

OUTLINE DIMENSIONS



COMPLIANT TO JEDEC STANDARDS MS-001
 CONTROLLING DIMENSIONS ARE IN INCHES; MILLIMETER DIMENSIONS (IN PARENTHESES) ARE ROUNDED-OFF INCH EQUIVALENTS FOR REFERENCE ONLY AND ARE NOT APPROPRIATE FOR USE IN DESIGN. CORNER LEADS MAY BE CONFIGURED AS WHOLE OR HALF LEADS.

Figure 1. 8-Lead Plastic Dual In-Line Package [PDIP] Narrow Body (N-8)

Dimensions shown in inches and (millimeters)

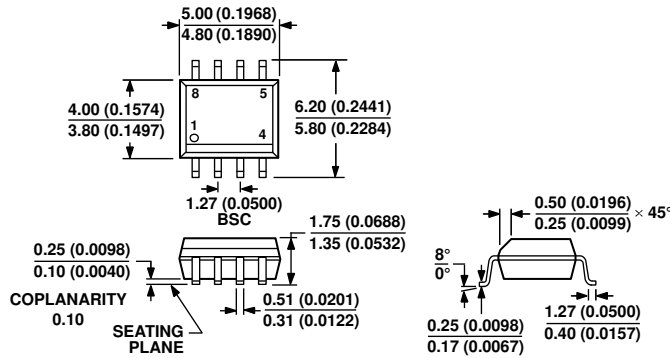

COMPLIANT TO JEDEC STANDARDS MS-012-AA
 CONTROLLING DIMENSIONS ARE IN MILLIMETERS; INCH DIMENSIONS (IN PARENTHESES) ARE ROUNDED-OFF MILLIMETER EQUIVALENTS FOR REFERENCE ONLY AND ARE NOT APPROPRIATE FOR USE IN DESIGN.

Figure 2. 8-Lead Standard Small Outline Package [SOIC_N] Narrow Body (R-8)

Dimensions shown in millimeters and (inches)

ORDERING GUIDE

Model ¹	Temperature Range	Package Description	Package Option
OP90GPZ	-40°C to +85°C	8-Lead PDIP	N-8
OP90GS	-40°C to +85°C	8-Lead SOIC_N	R-8
OP90GS-REEL	-40°C to +85°C	8-Lead SOIC_N	R-8
OP90GS-REEL7	-40°C to +85°C	8-Lead SOIC_N	R-8
OP90GSZ	-40°C to +85°C	8-Lead SOIC_N	R-8
OP90GSZ-REEL	-40°C to +85°C	8-Lead SOIC_N	R-8
OP90GSZ-REEL7	-40°C to +85°C	8-Lead SOIC_N	R-8

¹ Z = RoHS Compliant Part.

REVISION HISTORY

12/11—Rev. B to Rev. C

Deleted 8-Lead Hermetic DIP (Z-Suffix) Package (Q-8).....Universal
 Changes to Electrical Characteristics 2
 Changes to Electrical Characteristics 4
 Changes to Absolute Maximum Ratings 5
 Changes to Figure 7, 2-Wire 4 mA to 20 mA Current Transmitter Section, and Figure 9 9
 Changes to Figure 10 and Figure 11..... 10
 Changes to Figure 12..... 11
 Updated Outline Dimensions 12
 Changes to Ordering Guide 12

5/02—Rev. A to Rev. B

Edits to 8-Lead SOIC Package (R-8)..... 12

9/01—Rev. 0 to Rev. A

Edits to Pin Connections..... 1
 Edits to Electrical Characteristics 2, 3, 4
 Edits to Ordering Information5
 Edits to Absolute Maximum Ratings.....5
 Edits to Package Type5
 Deleted OP90 Dice Characteristics.....5
 Deleted Wafer Test Limits5