

FUNCTION	PART NUMBER	MATERIAL/FINISH	PACKAGING			
			TAPE AND REEL			
FRAME	BMI-S-210-F	.20MM 1008/1010 PRE-PLATED COLD ROLLED STEEL 1/2 HARD 1.25-5.00 MICRONS 100% MATTE TIN	REEL DIAMETER	TAPE WIDTH	PITCH	QUANTITY
			381MM	56MM	40MM	370
COVER	BMI-S-210-C	.20MM 1008/1010 PRE-PLATED COLD ROLLED STEEL 1/2 HARD 1.25-5.00 MICRONS 100% MATTE TIN	BULK PACK			

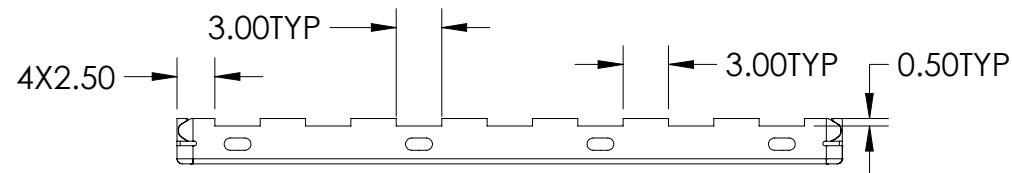

NOTES:

- OTHER MATERIAL OPTIONS MAY BE AVAILABLE, CONSULT SALES
- OTHER PACKAGING OPTIONS MAY BE AVAILABLE, CONSULT SALES

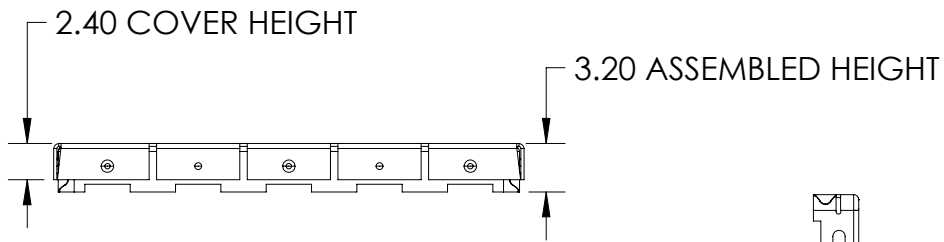
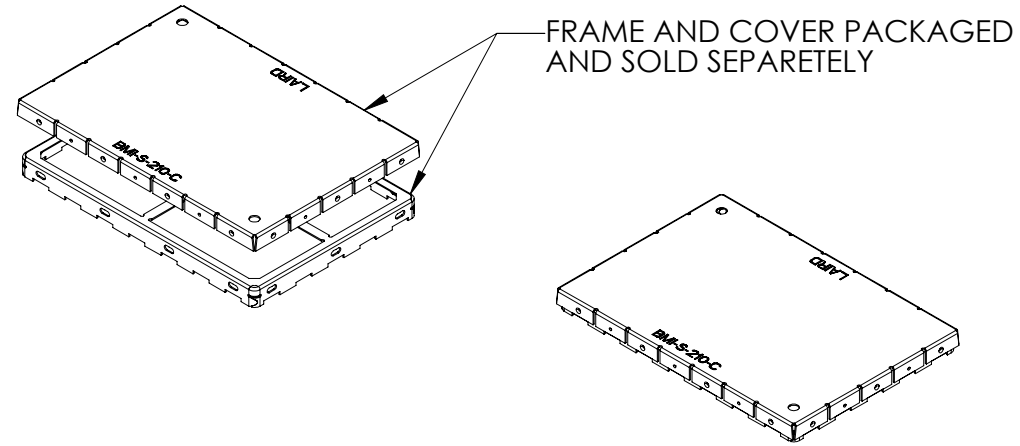
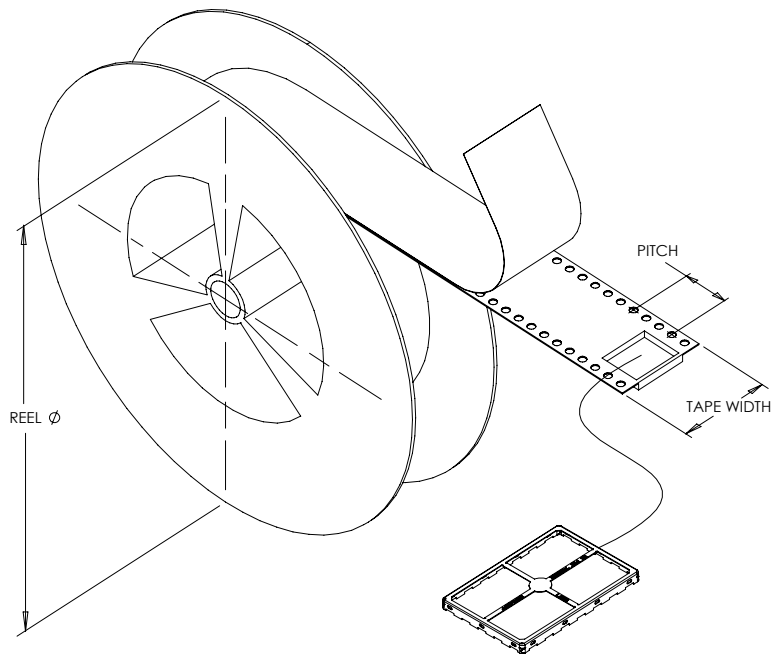
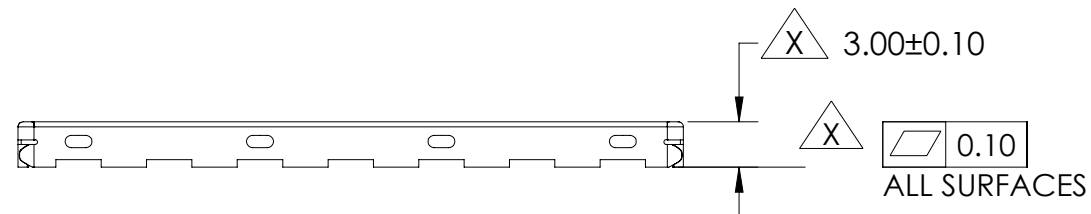
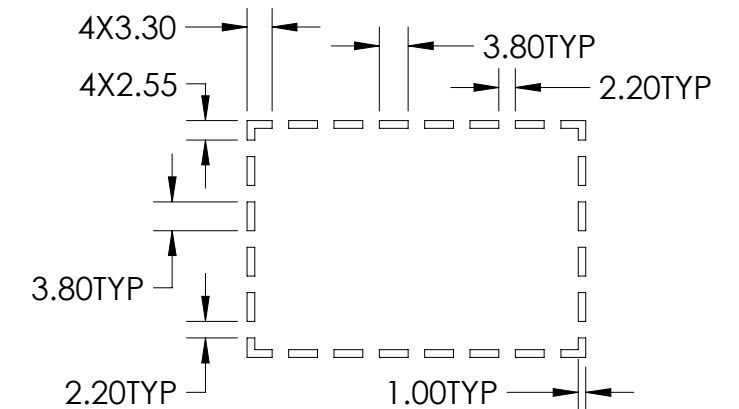
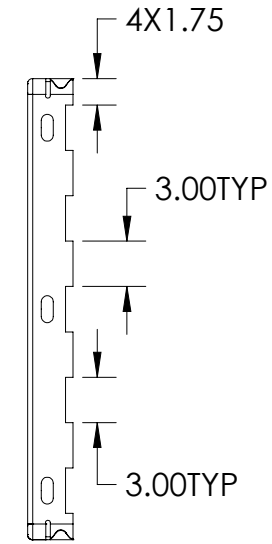
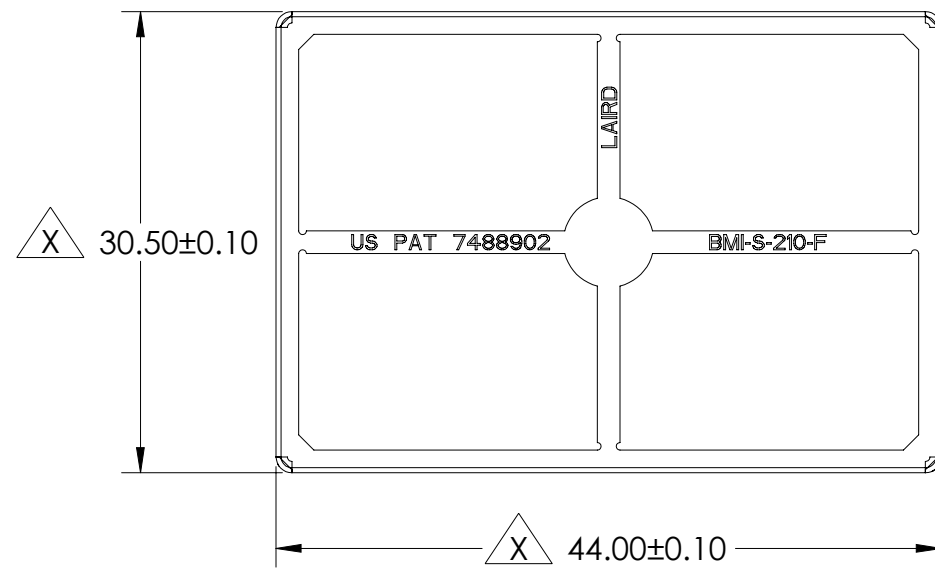

PART MARKING ON SIDES IS NOT INTENDED TO BE RELEVANT TO PART ORIENTATION IN CARRIER TAPE.

CRITICAL DIMENSIONS ARE DESIGNATED BY X

US PATENT 7488902

		PART DESCRIPTION: BOARD LEVEL SHIELD		LAIRD PART NUMBER: BMI-S-210-SALES	
		CUSTOMER: LAIRD CATALOG			
3RD ANGLE PROJECTION	DESIGNED IN SOLIDWORKS	PROGRAM NAME: STANDARDS	MODEL BY: AT	DATE: 07/14/20	REV: SALES
SCALE: 2:1	SHEET 1 OF 1	CUSTOMER PART NUMBER: N/A	APPROVED BY: X	DATE: XX/XX/XXXX	
<small>INFORMATION CONTAINED IN THIS DOCUMENT IS CONFIDENTIAL AND PROPRIETARY TO LAIRD TECHNOLOGIES. IT MAY NOT BE DISCLOSED TO ANYONE WITHOUT WRITTEN AUTHORIZATION FROM LAIRD TECHNOLOGIES</small>					