

| P | LTR | DESCRIPTION | DATE | DWN | APVD |
|---|-----|------------------------|---------|-----|------|
| | A3 | REVISED(ECR-13-010163) | 24JUN13 | P.H | H.K |

WITH CAP CONDITION

2129392-2; AS SHOWN

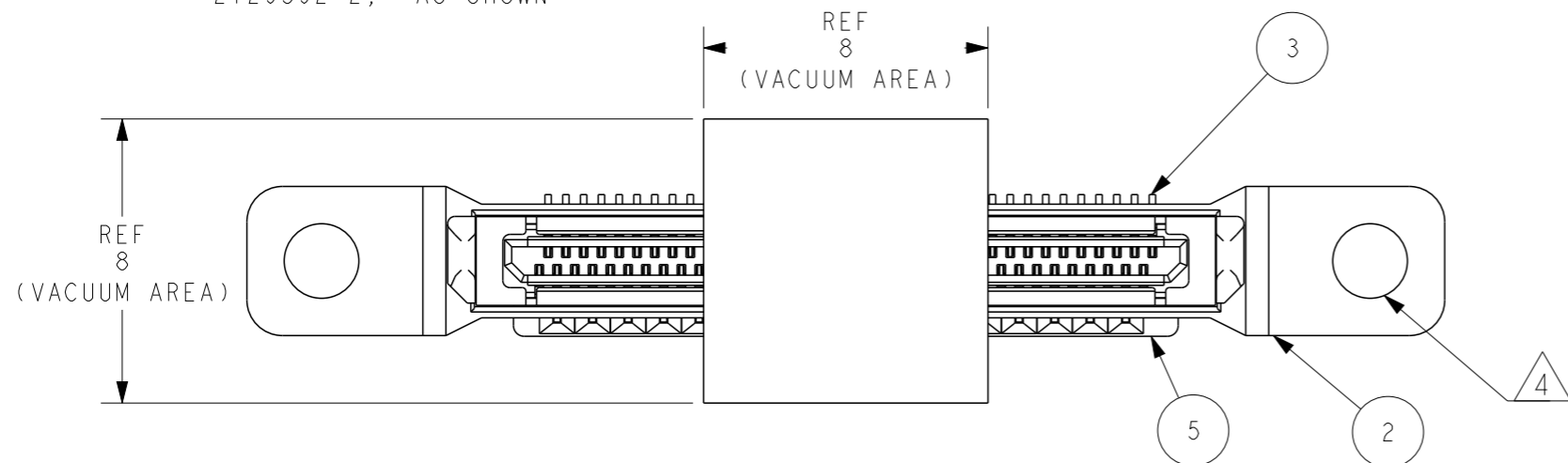

- MATERIAL:
 - ① HOUSING: LCP(UL94V-0, BLACK)
 - ② SHELL: STAINLESS STEEL SUS304
 - ③ CONTACT: PHOSPHOR BRONZE
 - ④ CAP: LCP(UL94V-0, BLACK)
 - ⑤ SPACER: LCP(UL94V-0, BLACK)
- FINISH:
 - CONTACT:
 - 0.38um MIN. AU PLATING AT CONTACT AREA
 - 0.1um MIN. MATTE TIN PLATING AT SOLDER TAIL
 - OVERALL 2um MIN. NICKEL PLATING
 - APPLY LUBRICANT TO CONTACT SURFACE
 - SHELL:
 - 2um MIN. NICKEL PLATING OVERALL.
- PRODUCT MUST MEET CONTROLLED SUBSTANCES PER TE SPEC: TEC-138-702
 - SPECIAL REQUEST OF LOW HALOGEN SPEC:
 - CHLORINE (Cl): 900ppm MAX.
 - BROMINE (Br): 900ppm MAX.
 - SPECIAL REQUEST OF REACH SvHC SPEC ON NON-MATAL MATERIAL:
 - DBP: 1000 ppm MAX.
 - DEHP: 1000 ppm MAX.
 - BBP: 1000 ppm MAX.
 - HBCDD: 1000 ppm MAX.

△ RECOMMAND SCREW TROQUE 1.8kg-cm MAX.

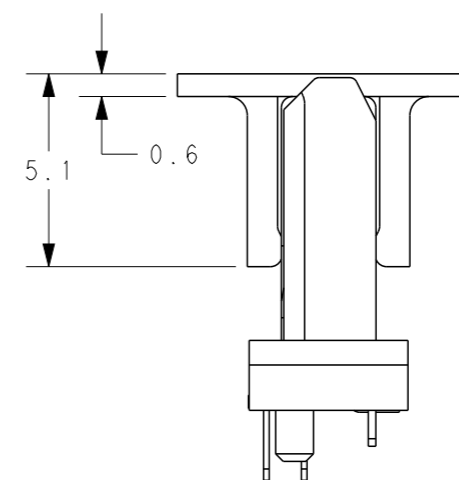
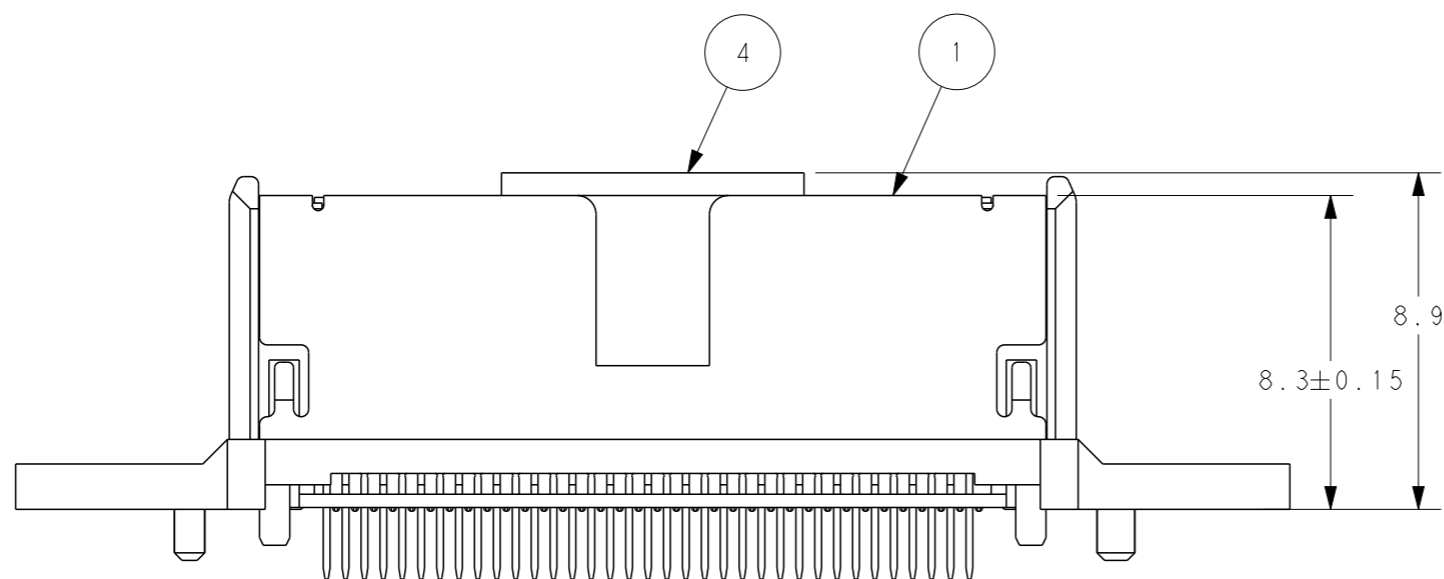

| Q'TY | NAME | ITEM |
|------|---------|------|
| 1 | SPACER | ⑤ |
| 1 | CAP | ④ |
| 70 | CONTACT | ③ |
| 1 | HOUSING | ② |
| 1 | SHELL | ① |

INFORMATION IS TE CONFIDENTIAL & PROPRIETARY

| | | | | |
|---|--|--------------------------------|---|--------------------|
| THIS DRAWING IS A CONTROLLED DOCUMENT. | | DWN P. HSU 13AUG2012 |  TE Connectivity | |
| DIMENSIONS: mm | | CHK M. CHAO 13AUG2012 | | |
| TOLERANCES UNLESS OTHERWISE SPECIFIED: | | APVD H. KODAMA 13AUG2012 | NAME DOCK CONNECTOR ASSEMBLY 0.5MM CL 70POS DOCKING CONNECTOR | |
| 0 PLC ±0.25 1 PLC ±0.25 2 PLC ±0.25 3 PLC ±0.25 4 PLC ±0.25 ANGLES ±5° | | PRODUCT SPEC 108-99038 | RESTRICTED TO | |
| MATERIAL | | APPLICATION SPEC | SIZE A3 | CAGE CODE 00779 |
| FINISH | | WEIGHT | DRAWING NO C=2129392 | SCALE 5:1 |
| | | CUSTOMER DRAWING | SHEET 1 | OF 4 |
| | | | REV A3 | |

LOC DW

DIST

REVISIONS

| P | LTR | DESCRIPTION | DATE | DWN | APVD |
|---|-----|-------------|------|-----|------|
| - | - | SEE SHEET 1 | - | - | - |

2129392-2 ; AS SHOWN

W/O CAP CONDITION

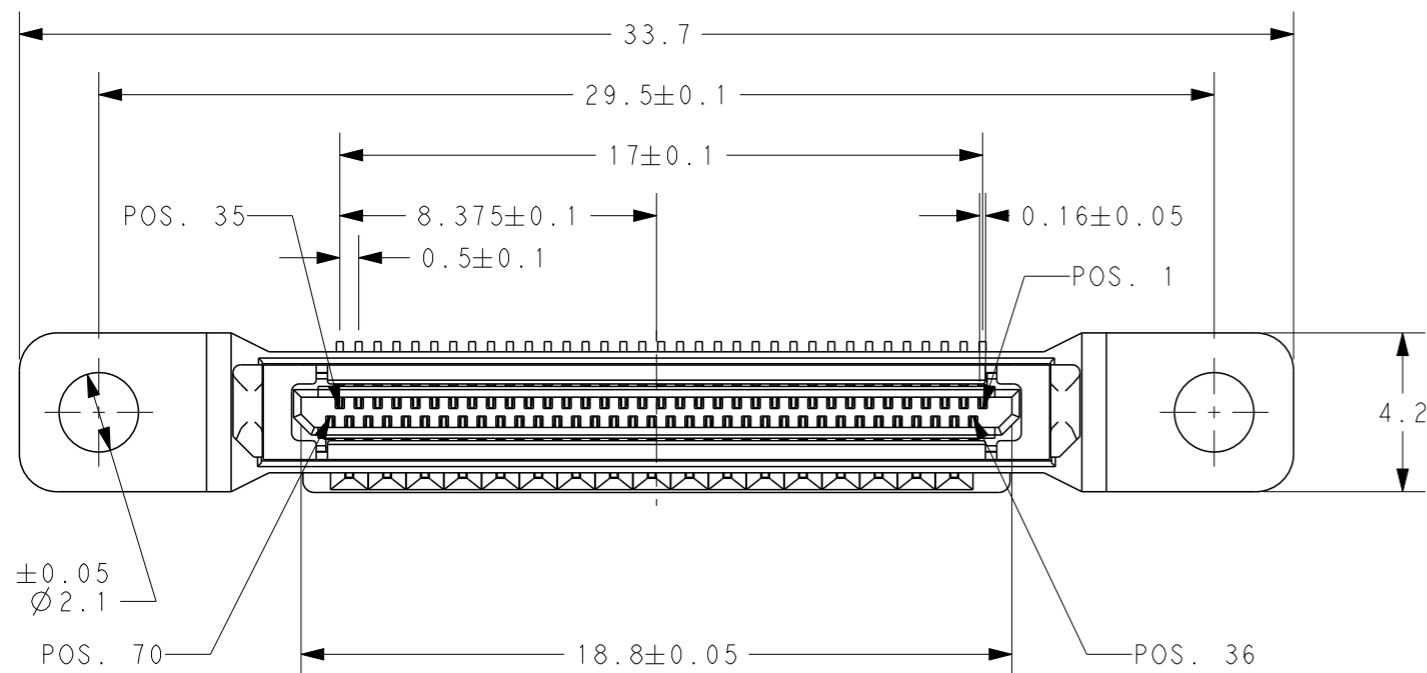

GND CONTACT POS NO 1, 35, 36, 70
SIG CONTACT POS NO OTHERS.

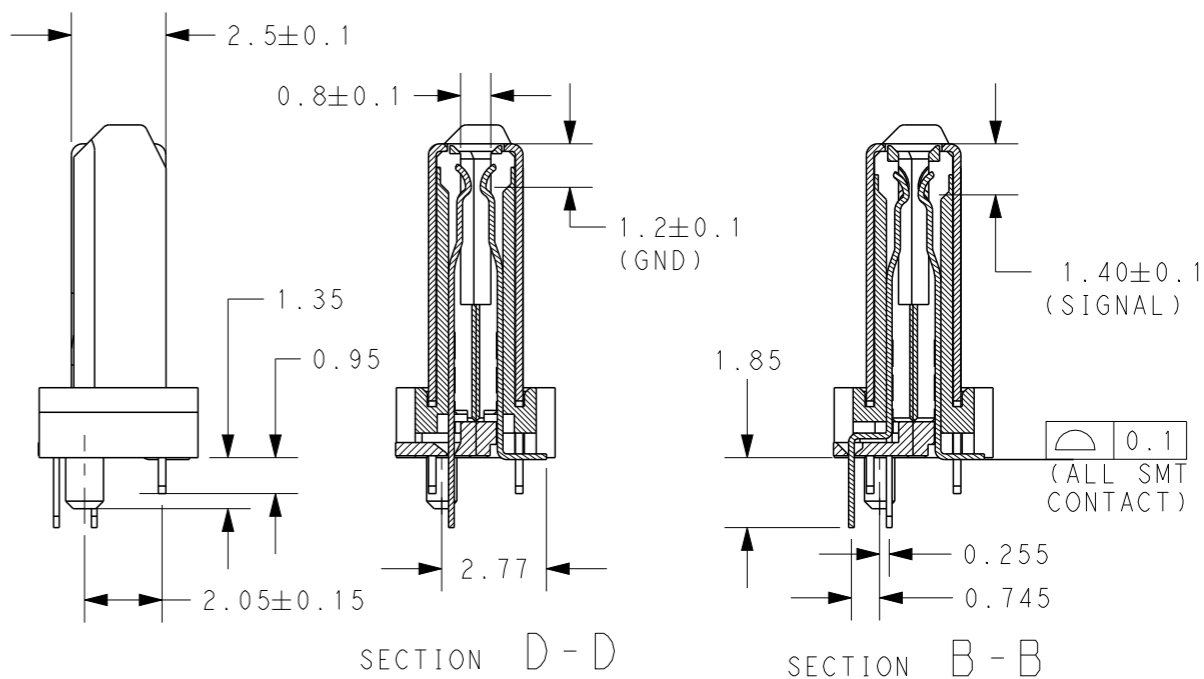
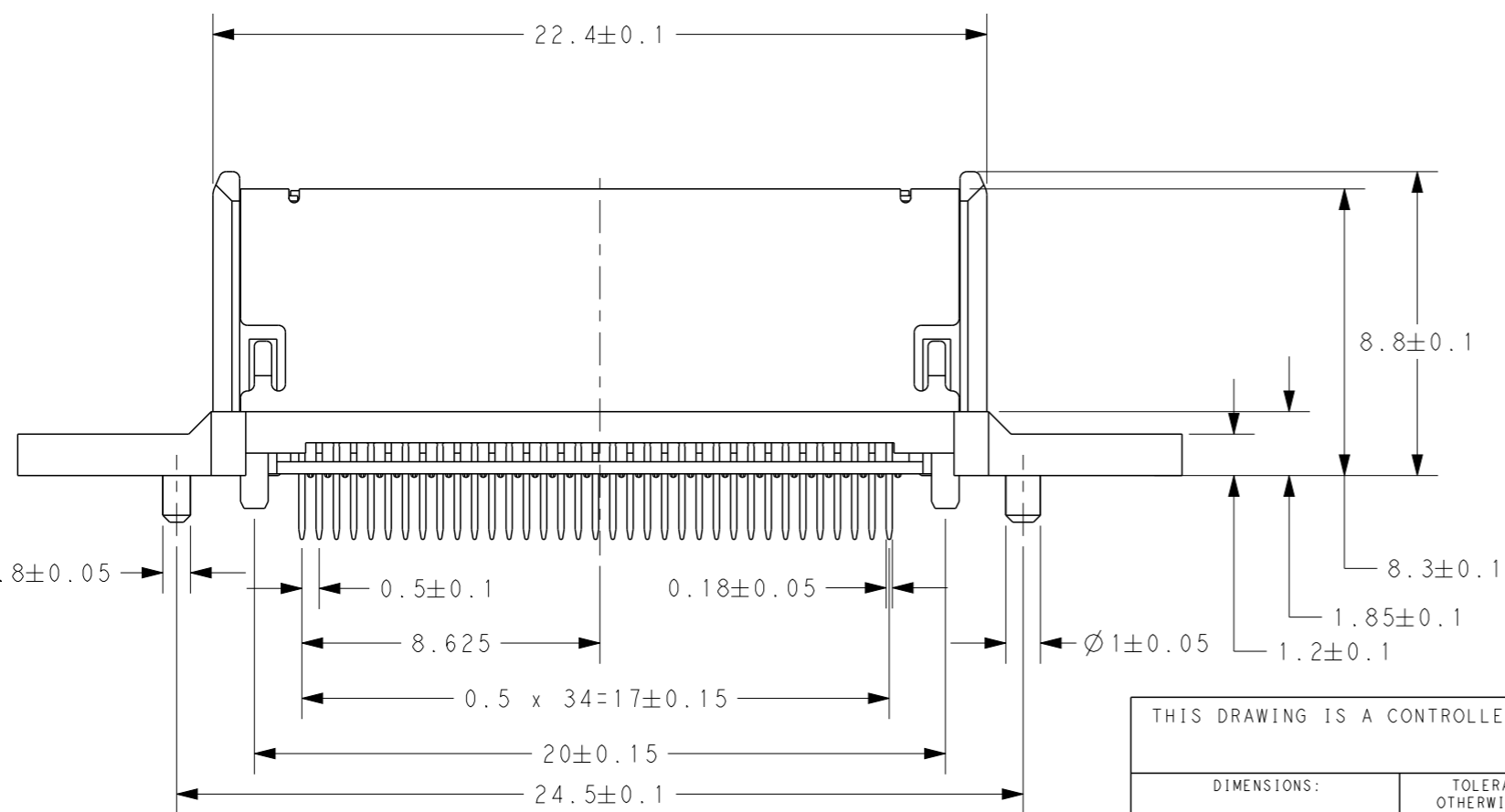

THIS DRAWING IS A CONTROLLED DOCUMENT.

| | |
|------------------|---|
| DWN | - |
| CHK | - |
| APVD | - |
| PRODUCT SPEC | - |
| APPLICATION SPEC | - |
| WEIGHT | - |
| CUSTOMER DRAWING | - |

DIMENSIONS: mm

TOLERANCES UNLESS OTHERWISE SPECIFIED:

| | |
|--------|-------|
| 0 PLC | ±0.25 |
| 1 PLC | ±0.25 |
| 2 PLC | ±0.25 |
| 3 PLC | ±0.25 |
| 4 PLC | ±0.25 |
| ANGLES | ±5 |
| FINISH | - |

STE TE Connectivity

NAME: DOCK CONNECTOR ASSEMBLY
0.5MM CL 70POS DOCKING CONNECTOR

| | | | |
|------|-----------|------------|---------------|
| SIZE | CAGE CODE | DRAWING NO | RESTRICTED TO |
| A3 | 00779 | C-2129392 | - |

SCALE 5:1 SHEET 2 OF 4 REV A3

INFORMATION IS TE CONFIDENTIAL & PROPRIETARY

THIS DRAWING IS UNPUBLISHED. RELEASED FOR PUBLICATION 20
 © COPYRIGHT 20 BY - ALL RIGHTS RESERVED.

| LOC | DIST | REVISIONS | | | | | |
|-----|------|-----------|-----|-------------|------|-----|------|
| DW | | P | LTR | DESCRIPTION | DATE | DWN | APVD |
| | | - | - | SEE SHEET 1 | - | - | - |

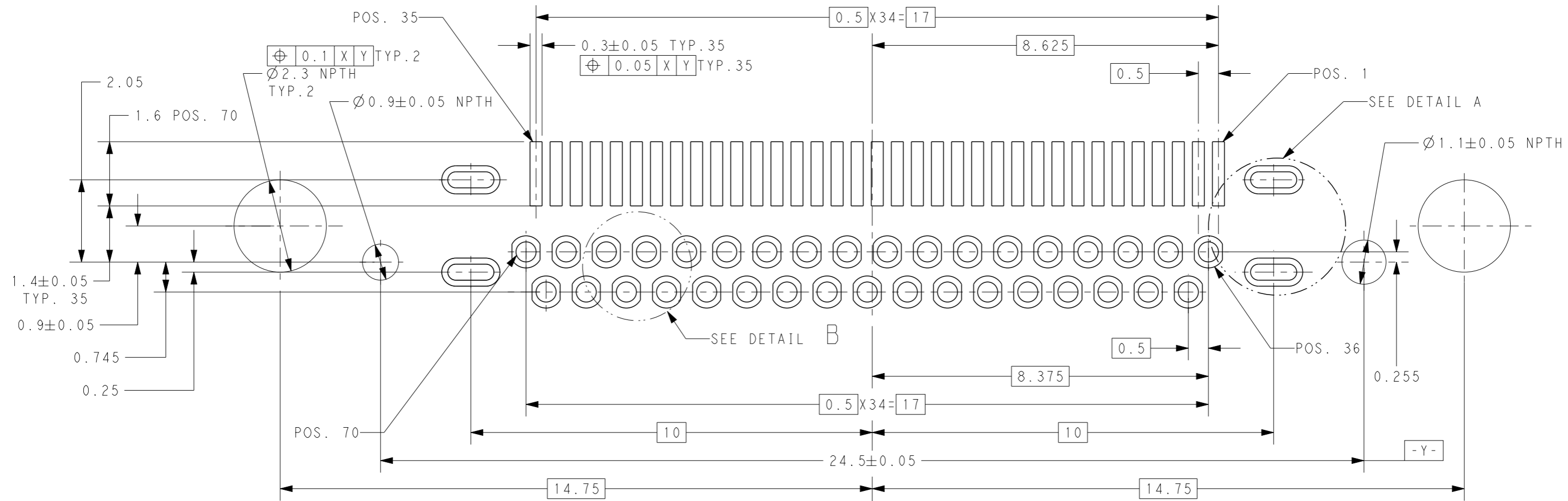

REFERENCE PCB LAYOUT
 GENERAL TOLERANCE: ±0.05

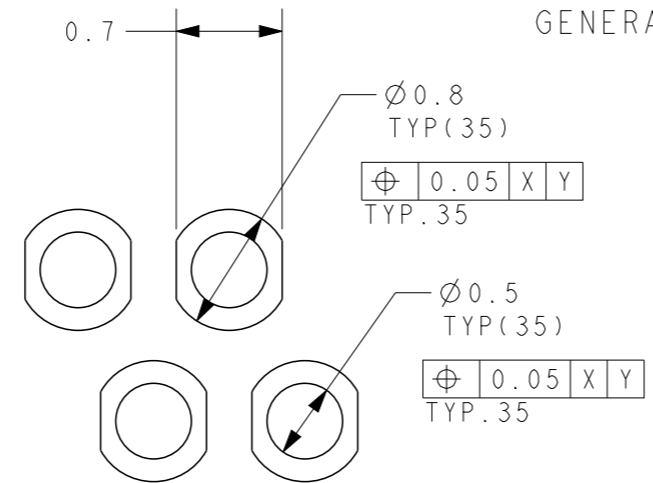
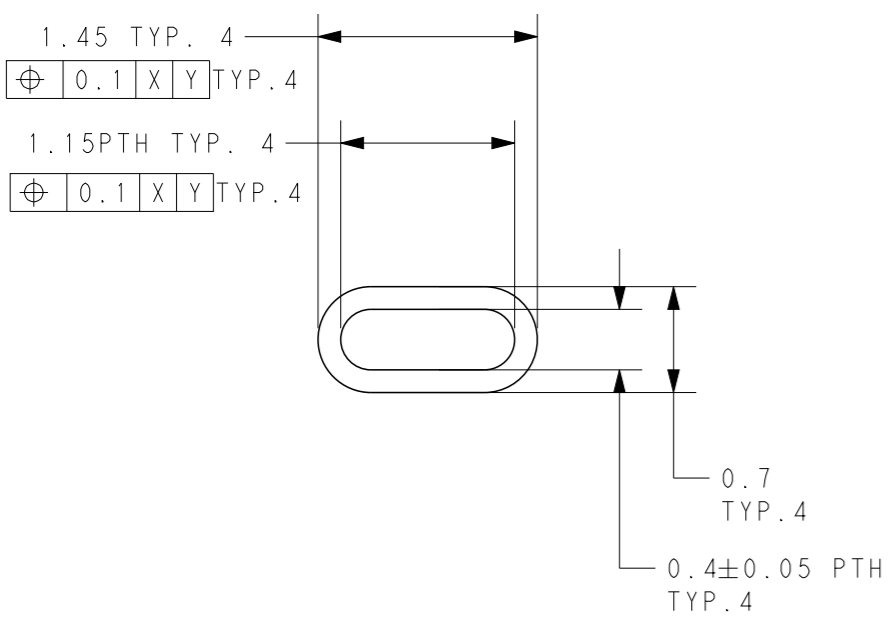

DETAIL B
 SCALE 20:1

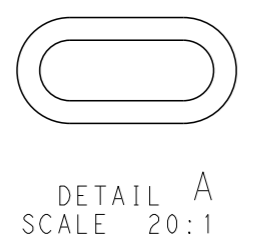

INFORMATION IS TE CONFIDENTIAL & PROPRIETARY

| | | | | |
|--|-------------|------------------|---|--|
| THIS DRAWING IS A CONTROLLED DOCUMENT. | | DWN | - | |
| DIMENSIONS: mm | | CHK | - | |
| TOLERANCES UNLESS OTHERWISE SPECIFIED: | | APVD | - | |
| 0 PLC | ±0.25 | PRODUCT SPEC | - | |
| 1 PLC | ±0.25 | APPLICATION SPEC | - | |
| 2 PLC | ±0.25 ±0.05 | WEIGHT | - | |
| 3 PLC | ±0.25 | | - | |
| 4 PLC | ±0.25 | | - | |
| ANGLES | ±5 | | - | |
| MATERIAL | - | | - | |
| FINISH | - | | - | |

STE TE Connectivity

NAME: DOCK CONNECTOR ASSEMBLY
 0.5MM CL 70POS DOCKING CONNECTOR

SIZE: A3 CAGE CODE: 00779 DRAWING NO: C-2129392

SCALE: 10:1 SHEET: 3 OF 4 REV: A3

| | |
|-----|------|
| LOC | DIST |
| DW | |

REVISIONS

| P | LTR | DESCRIPTION | DATE | DWN | APVD |
|---|-----|-------------|------|-----|------|
| - | - | SEE SHEET 1 | - | - | - |

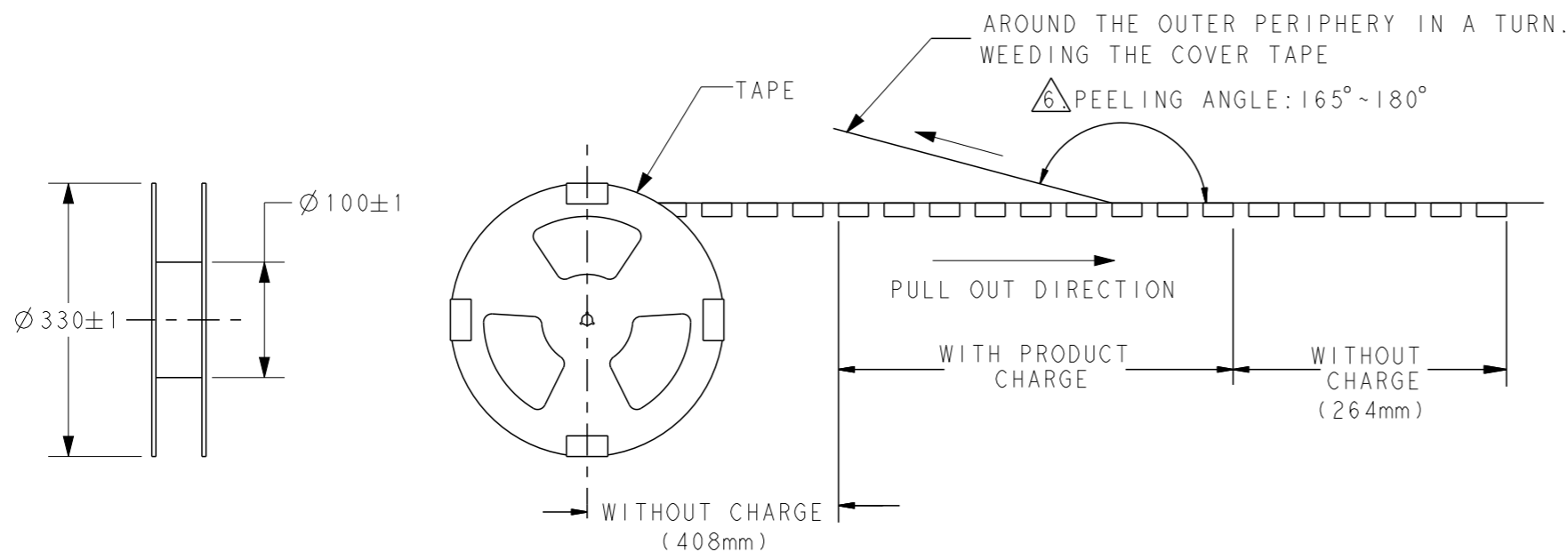
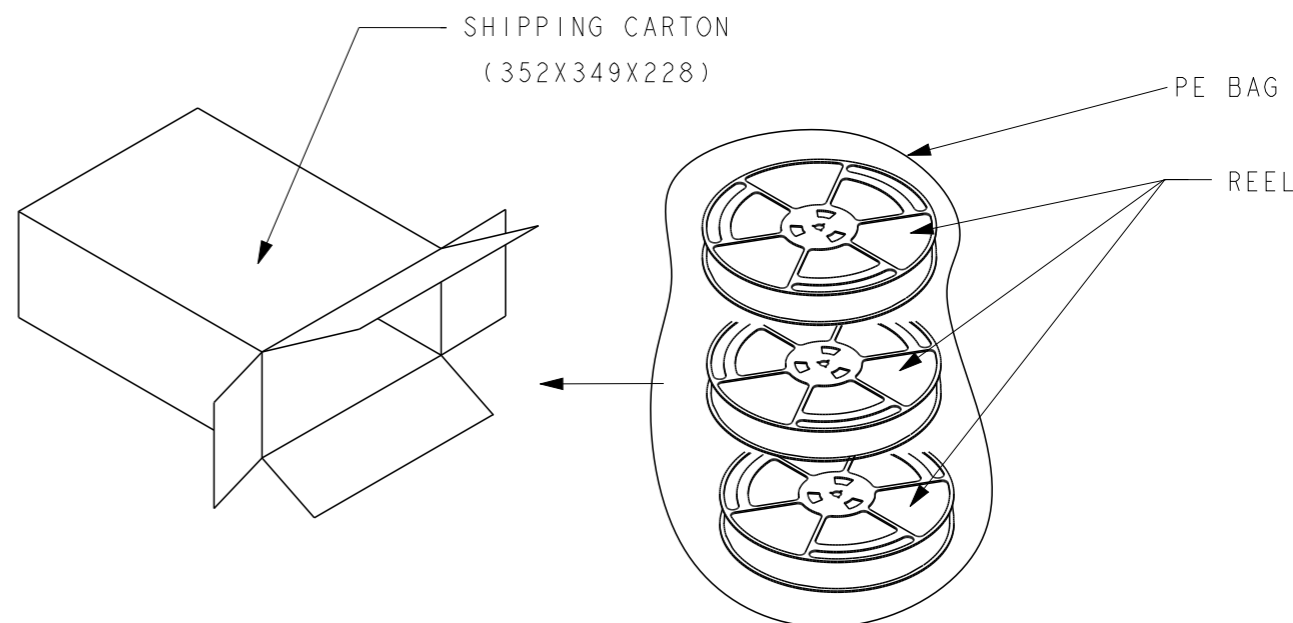
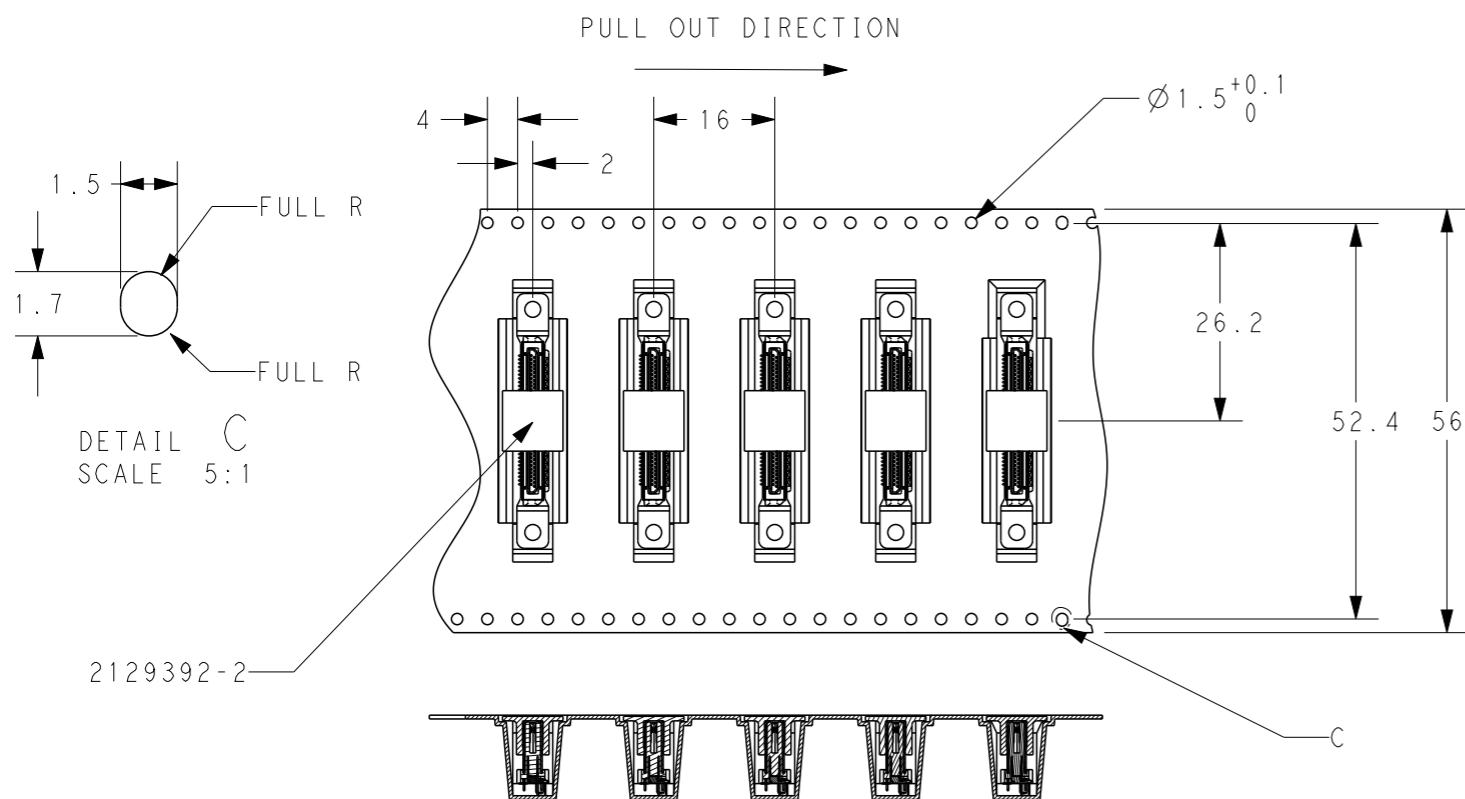

- 5. PACKING MATERIAL:
CARRY TAPE: PS; COLOR: CLEAR.
COVER TAPE: PET; COLOR: SMOKE.
- 6. PEELING STRENGTH OF COVER TAPE: 0.2N~1.2N

| | | | |
|-----------|----------|--------------|----------------|
| 2129392-2 | 300 | 3 | 900 |
| P/N | PCS/TAPE | REELS/CARTON | TOTAL QUANTITY |

INFORMATION IS TE CONFIDENTIAL & PROPRIETARY

THIS DRAWING IS A CONTROLLED DOCUMENT.

| | |
|-------------|--|
| DIMENSIONS: | TOLERANCES UNLESS OTHERWISE SPECIFIED: |
| mm | |
| | 0 PLC ±0.25 |
| | 1 PLC ±0.25 |
| | 2 PLC ±0.25 |
| | 3 PLC ±0.25 |
| | 4 PLC ±0.25 |
| | ANGLES ±5° |
| MATERIAL | FINISH |

| | |
|------------------|---|
| DWN | - |
| CHK | - |
| APVD | - |
| PRODUCT SPEC | - |
| APPLICATION SPEC | - |
| WEIGHT | - |
| CUSTOMER DRAWING | - |

TE TE Connectivity

NAME DOCK CONNECTOR ASSEMBLY
0.5MM CL 70POS DOCKING CONNECTOR

| | | | |
|------|-----------|------------|---------------|
| SIZE | CAGE CODE | DRAWING NO | RESTRICTED TO |
| A3 | 00779 | C-2129392 | - |

SCALE 1:1 SHEET 4 OF 4 REV A3