



## 17 PORT GIGABIT ETHERNET SWITCHING PROCESSOR

### FEATURES

- Supports 17 Gigabit Ethernet ports in wirespeed operation
- Gigabit Ethernet ports support RGMII interfaces to Standard GE Transceivers
- Uplink port supports GMII interface
- On-chip L2 search table supports 8K MAC addresses
- Jumbo Frame support (9 Kbyte)
- Supports 4K VLAN address and 802.1s Multiple Spanning Tree protocol
- Supports 802.1w Rapid Spanning Tree
- Supports 802.1p and/or DiffServ with four priority queues
- Supports 802.3ad link aggregation
- Supports selected MIB groups in RMON
- Supports up to 256 IP multicast groups
- Full-duplex and half-duplex operation with IEEE 802.3x flow control and backpressure
- On-chip 512 Kbyte packet buffer memory with sophisticated buffer management
- Offers per-port rate control
- Supports 802.1x access control protocol
- Extremely low power consumption (4W)
- Packaged in 676-pin BGA

### SUMMARY OF BENEFITS

- Enables a new generation of lower-cost switches with Gigabit Ethernet connectivity and much smaller form factors.
- Complete switch on a chip integrates multilayer forwarding and filtering logic and internal ARL tables and packet buffering.
- Filters and forwards traffic at full wirespeed on all 17 ports at all layers of functionality. This equates to 34 Gbps of bandwidth.
- Provides the most cost-effective Gigabit Ethernet connectivity to the desktop for all remote and branch office as well as enterprise workgroup needs.
- Supports 8K internal MAC addresses so even large, segmented networks can be supported.
- Supports Quality of Service (QoS) for prioritization of different traffic types.
- Full support of VLANs allows separation of user groups and minimizes superfluous traffic.
- Jumbo frame support allows the device to be connected to corporate server farms and networks while maintaining maximum TCP/IP performance.
- Supports the latest standards used in corporate networks for discovery, management, access control, and traffic control.
- On-chip MIB registers allows the collection and transmission of statistics for each port and allows an upward migration path for corporate users.

### 17 Gigabit Ethernet Ports for SOHO and Subnetwork Applications

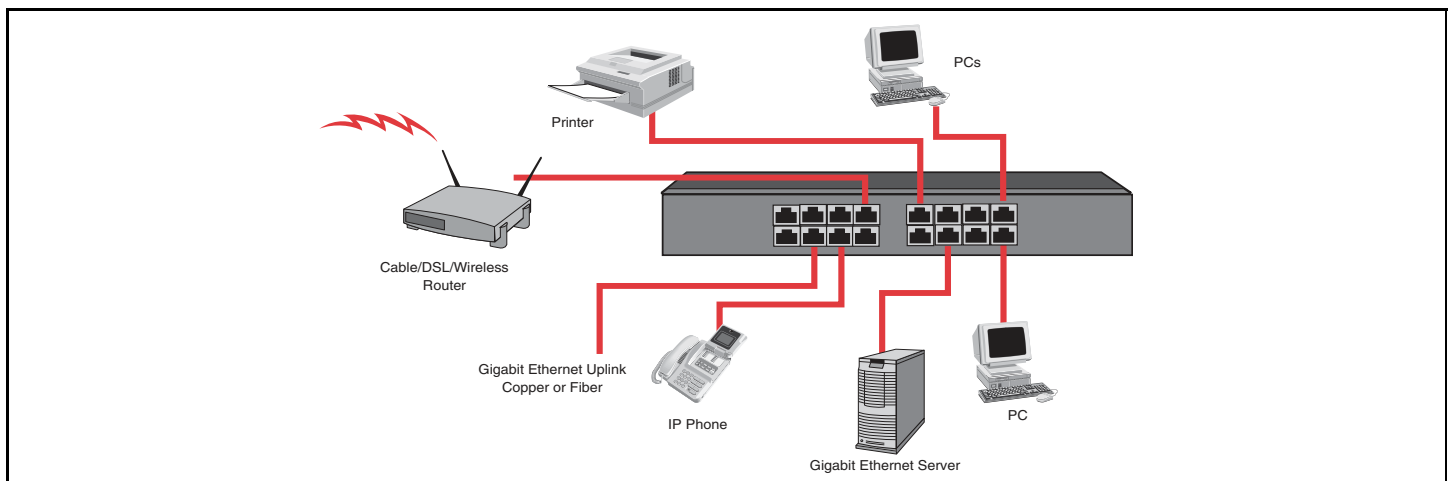

## OVERVIEW

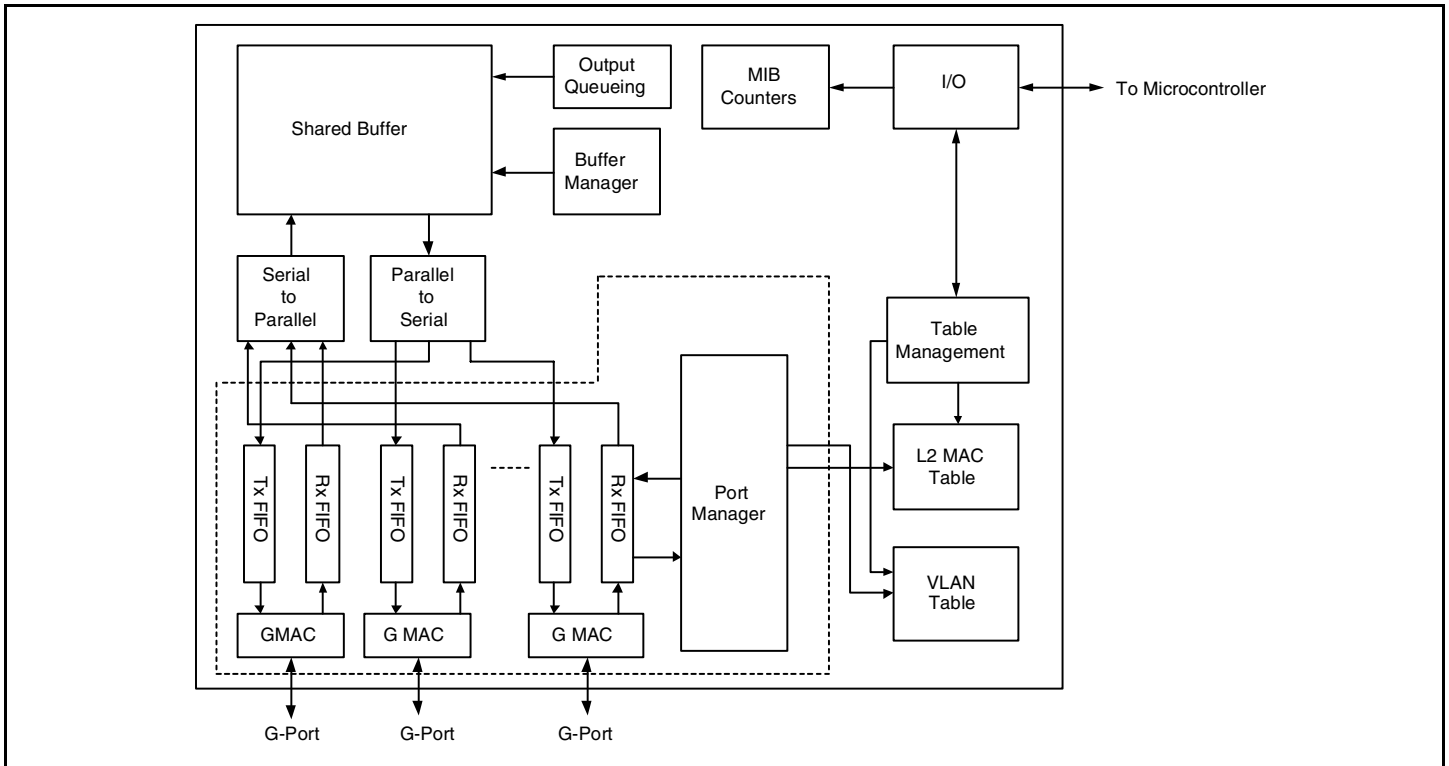

The Broadcom BCM5346 device is a highly integrated solution providing connectivity for 17 ports of Gigabit Ethernet. It combines all the functions of a high-speed switch system, including packet buffer, media access controllers, address management, and a nonblocking switch fabric as well as a Microcontroller interface into a single 0.13  $\mu\text{m}$  CMOS device. It complies with IEEE 802.3, 802.3u, 802.3ab, and 802.3x specifications, including the MAC control, pause frame, and auto-negotiation subsections, providing compatibility with all industry-standard Ethernet, Fast Ethernet, and Gigabit Ethernet devices.

The BCM5346 is ideal for applications such as Gigabit Ethernet workgroup switches, desktop switches, and data center switches.

The BCM5346 supports 17 Gigabit Ethernet ports in a single device with all ports in wire speed operation. It offers 16 ports of RGMII (802.3ab, 1000BASE-T) interfaces with full-duplex operation at Gigabit Ethernet

speed and full-duplex or half-duplex operation at 10/100 Mbps speed (using 10BASE-T/100BASE-T).

The BCM5346 also offers one uplink port with a GMII interface for light management or cascading purposes. It forwards Ethernet frames with lengths between 64 bytes and 9216 bytes based on L2 MAC address lookups in the 8k entry on-chip MAC address table with automatic learning and aging support. The device supports four levels of priority that can be either assigned from the 802.1p user priority bits or the TOS field for Differentiated Services. The device also supports MAC access control (802.1x) as well as port trunking (802.3ad). In addition, individual ports can be rate controlled in 16 steps down to 64 Kbps.

The BCM5346 device offers a Microcontroller interface to support lightly managed applications. All the required counters and frame trapping mechanisms are incorporated into the device.

**Broadcom**<sup>®</sup>, the pulse logo, and **Connecting everything**<sup>®</sup> are trademarks of Broadcom Corporation and/or its subsidiaries in the United States and certain other countries. All other trademarks mentioned are the property of their respective owners.

Connecting  
**everything**<sup>®</sup>



**BROADCOM CORPORATION**  
16215 Alton Parkway, P.O. Box 57013  
Irvine, California 92619-7013

© 2004 by BROADCOM CORPORATION. All rights reserved.

5346-PB02-R 03/25/04

Phone: 949-450-8700  
Fax: 949-450-8710  
E-mail: [info@broadcom.com](mailto:info@broadcom.com)  
Web: [www.broadcom.com](http://www.broadcom.com)