

# Board Level Heat Sinks

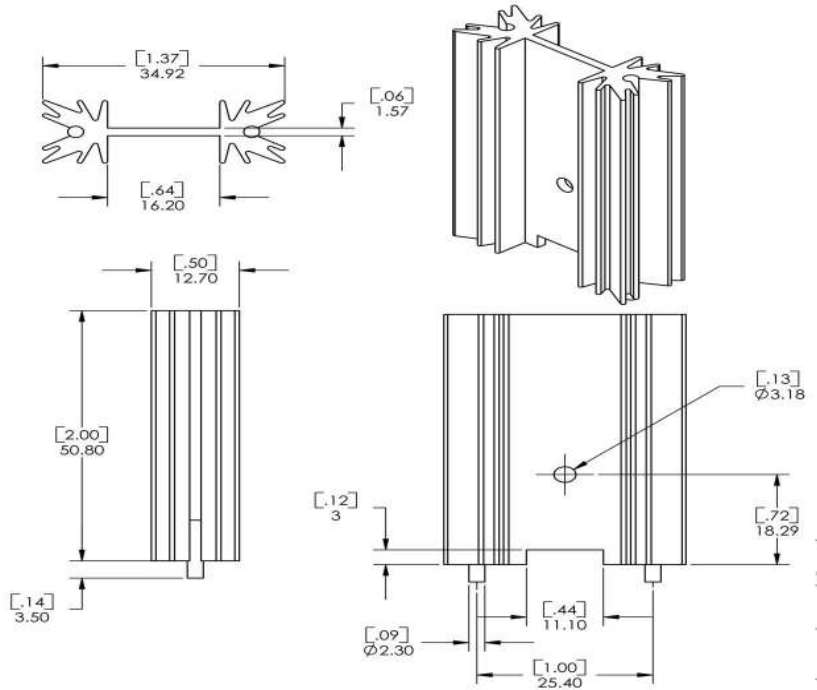

ThermaFlo

P/N: 411320B02500

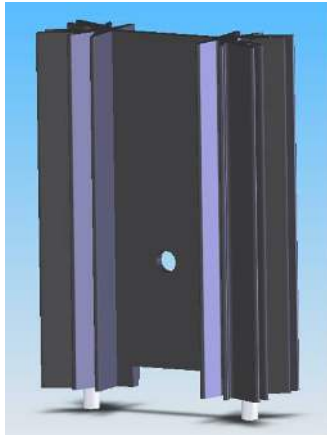

## PRODUCT SPECIFICATIONS

- Devices: TO-218, TO-220 & TO-247
- Size: 12.7 x 34.9 x 50.8 mm
- Material: Aluminum
- Weight: 20.9 g
- Type: Stamped
- Finish: Black Anodized
- PCB Mounting: Solderable Pins
- Package: Bulk
- Accessories: Hardware & Thermal Interface Material

## FEATURES & BENEFITS

- Hole for Device Attachment
- Dual Device Cooling Heat Sink
- Vertical Mounting via Solderable Pins
- RoHS Compliant



## CUSTOMIZED HEATSINKS

- Specialized Plating
- Specialized Body Configurations
- Contact Applications Engineering

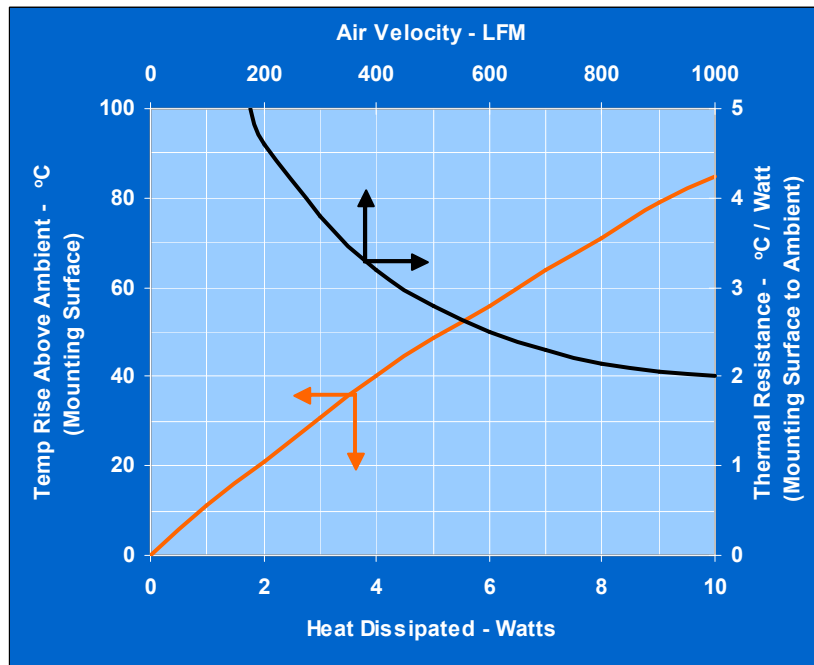

TO-218, TO-220 & TO-247

## COMAIR ROTRON, INC

8929 Terman Court, San Diego, CA 92121

Ph (858) 348-6200 Fax (858) 566-4577

E-mail: sales@comairrotron.com,

Web: www.comairrotron.com