



SY89312V

3.3V/5V, 4GHz PECL/ECL
÷2 Clock Generator

Precision Edge®



Precision Edge®

General Description

The SY89312V is an integrated ÷2 divider with differential clock inputs. It is functionally equivalent to the SY100EP32V but in an ultra-small 8-pin QFN package that features a 70% smaller footprint.

The V_{BB} pin, an internally generated voltage supply, is available for this device only. For single-ended input conditions, the unused differential input is connected to V_{BB} as a switching reference voltage. V_{BB} can also bias AC-coupled inputs. When used, decouple V_{BB} and V_{CC} via a 0.01 μ F capacitor and limit current sourcing or sinking to 0.5mA. When not in use, V_{BB} should be left open.

The reset pin is asynchronous and is asserted when it is high. Upon power-up, the internal flip-flops will be in a random state; the reset allows for the synchronous use of multiple SY89312Vs in a system.

Datasheets and support documentation are available on Micrel's web site at: www.micrel.com.

Features

- Guaranteed AC performance over temperature and voltage:
- >4GHz f_{MAX} input
- <160ps t_r/t_f
- <440ps t_{pd}
- 3.3V and 5V power supply operation
- 100k ECL/PECL-compatible I/O
- Internal 75K Ω input pull-down resistors
- Wide operating temperature range: -40°C to +85°C
- Available in ultra-small 8-pin 2mm x 2mm QFN package

Truth Table⁽¹⁾

CLK	/CLK	RESET	Q	/Q
X	X	H	L	H
$\bar{\square}$	$\bar{\square}$	L	F	F

Note:

1. F = Divide by 2 function.

Ordering Information

Part Number	Package Type	Operating Range	Package Marking	Lead Finish
SY89312VMGTR ⁽²⁾	8-pin 2mm × 2mm QFN	Industrial	312 with Pb-Free Bar Line Indicator	Pb-Free NiPdAu

Note:

2. Pb-Free package is recommended for new designs.

Pin Configuration

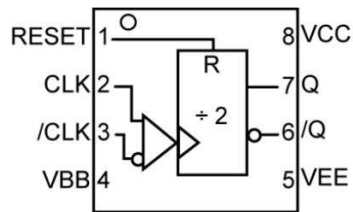

8-Pin 2mm × 2mm QFN

Pin Description

Pin Number	Pin Name	Type	Pin Function
2, 3	CLK, /CLK	100K ECL/PECL Input	Differential PECL/ECL Input: Internal 75kΩ pull-down resistor. If left open, pin defaults LOW (see Input Interface Applications section for single-ended inputs).
7, 6	Q, /Q	100K ECL/PECL Output	Differential PECL/ECL Output: Output CLK input divided by 2 (see Output Interface Applications section for recommendations on terminations).
8	VCC	Positive Power Supply	Positive Power Supply: Bypass with 0.1 μ F low ESR capacitor.
5	VEE, ePad	Negative Power Supply	Negative Power Supply: VEE and exposed pad (ePad) must be tied to most negative supply. For PECL/LVPECL connect to ground.
4	VBB	Reference Voltage Output	Bias Reference Voltage: VCC-1.4V. Used as reference voltage for single-ended inputs or AC-coupling to the CLK, /CLK inputs. Maximum sink/source is ± 0.5 mA (see Input Interface Applications section).
1	Reset	100k ECL/PECL Input	Single-Ended Input: PECL/ECL asynchronous reset.

Absolute Maximum Ratings⁽³⁾

Supply Voltage ($ V_{CC} - V_{EE} $)	+6.0V
Input Voltage (V_{IN})	-0.5V to V_{CC}
LVPECL Output Current (I_{OUT})	
Continuous	50mA
Surge	100mA
Current (V_{BB})	
Source or Sink on V_{BB} ⁽⁶⁾	± 1.5 mA
Lead Temperature (soldering, 20s)	260°C
Storage Temperature (T_s)	-65°C to +150°C

Operating Ratings⁽⁴⁾

Supply Voltage ($ V_{CC} - V_{EE} $)	+3.0 to +3.6V
Ambient Temperature (T_A)	-40°C to +85°C
Package Thermal Resistance ⁽⁵⁾	
QFN (θ_{JA})	
Still Air	93°C/W
500lfpm	87°C/W
QFN (ψ_{JB})	
Junction-to-Board	56°C/W

PECL/ECL (100K) DC Electrical Characteristics

$V_{CC} = +3.3V \pm 10\%$ or $+5V \pm 10\%$ and $V_{EE} = 0V$; $V_{CC} = 0V$ and $V_{EE} = -3.3V \pm 10\%$ or $-5V \pm 10\%$; $R_L = 50\Omega$ to $V_{CC} - 2V$;
 $T_A = -40^\circ\text{C}$ to $+85^\circ\text{C}$ unless otherwise stated.

Symbol	Parameter	Condition	Min.	Typ.	Max.	Units
I_{EE}	Power Supply Current	Maximum V_{CC} , no load	—	30	42	mA
V_{OH}	Output HIGH Voltage		$V_{CC} - 1.145$	—	$V_{CC} - 0.895$	V
V_{OL}	Output LOW Voltage		$V_{CC} - 1.945$	—	$V_{CC} - 1.695$	V
V_{IH}	Input HIGH Voltage		$V_{CC} - 1.225$	—	$V_{CC} - 0.88$	V
V_{IL}	Input LOW Voltage		$V_{CC} - 1.945$	—	$V_{CC} - 1.625$	V
V_{IHCMR}	Input HIGH Voltage Common Mode Range ⁽⁷⁾		$V_{EE} + 2.0$	—	V_{CC}	V
V_{BB}	Bias Voltage		$V_{CC} - 1.525$	$V_{CC} - 1.425$	$V_{CC} - 1.325$	V
I_{IH}	Input HIGH Current		—	—	150	μA
I_{IL}	Input LOW Current CLK		0.5	—	—	μA
	Input LOW Current /CLK		-150	—	—	

Notes:

- Permanent device damage may occur if absolute maximum ratings are exceeded. This is a stress rating only and functional operation is not implied at conditions other than those detailed in the operational sections of this data sheet. Exposure to absolute maximum rating conditions for extended periods may affect device reliability.
- The data sheet limits are not guaranteed if the device is operated beyond the operating ratings.
- Package thermal resistance assumes exposed pad is soldered (or equivalent) to the devices most negative potential on the PCB.
- Due to the limited drive capability use for input of the same package only.
- V_{IHCMR} (minimum) varies 1:1 with V_{EE} , (maximum) varies 1:1 with V_{CC} .

AC Electrical Characteristics⁽⁸⁾

PECL: $V_{CC} = +3.3V \pm 10\%$ or $+5V \pm 10\%$ and $V_{EE} = GND$; ECL: $V_{EE} = -3.3V \pm 10\%$ or $-5V \pm 10\%$ and $V_{CC} = GND$; $R_L = 50\Omega$ to $V_{CC} - 2V$; $T_A = -40^\circ C$ to $+85^\circ C$ unless otherwise stated.

Symbol	Parameter	Condition	Min.	Typ.	Max.	Units
f_{MAX}	Maximum Input Frequency		4	—	—	GHz
t_{pd}	Propagation Delay to Output Differential RESET, CLK → Q, /Q		250	275	440	ps
t_{RR}	Set/Reset Recovery		200	100	—	ps
t_{PW}	Minimum Pulse Width RESET		550	200	—	ps
t_{JITTER}	Cycle-to-Cycle RMS Jitter		—	—	1	psRMS
V_{PP}	Input Voltage Swing (Differential)		150	800	1200	mV
t_r, t_f	Output Rise/Fall Times Q, /Q (20% to 80%)		50	100	160	ps

Note:

8. Measured using a 750mV source, 50% duty cycle clock source

Timing Diagram

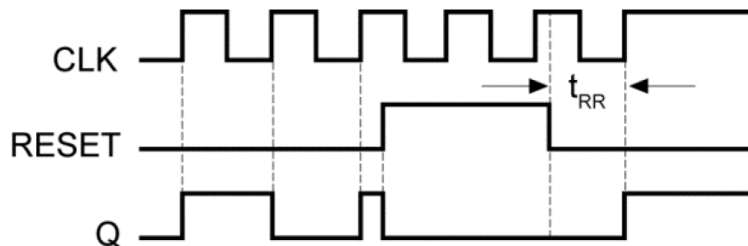

Input Interface Applications

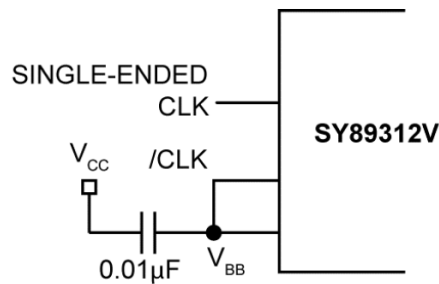

Figure 1. Single-Ended LVPECL Input (Terminating Unused Input)

LVPECL Output Interface Applications

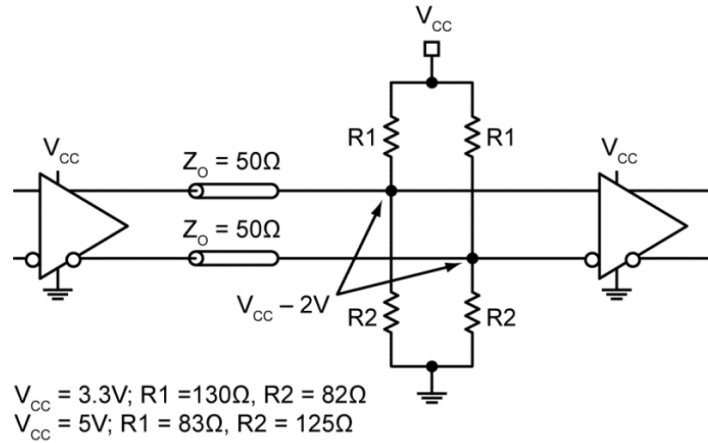

Figure 2. Parallel Thevenin-Equivalent Termination

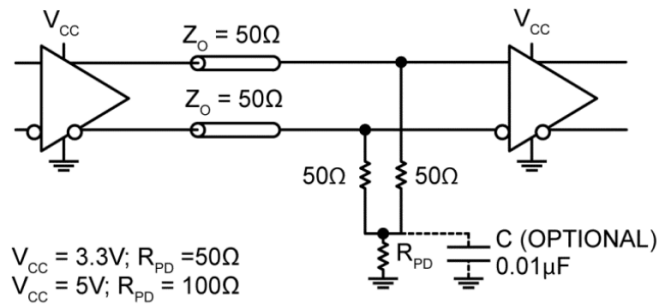

Figure 3. Three Resistor "Y Termination"

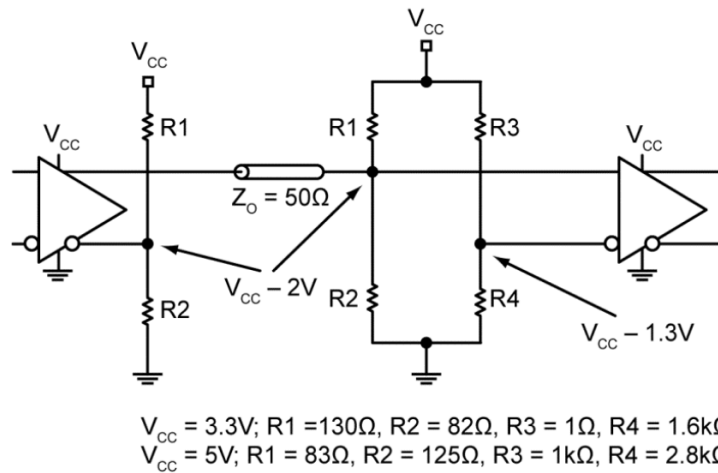
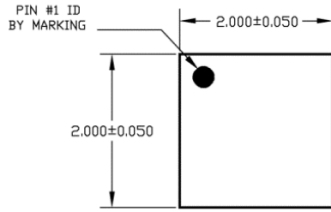
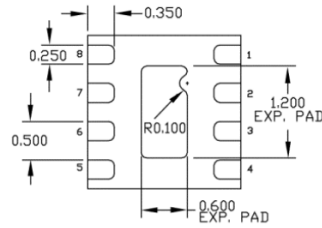

Figure 4. Terminating Unused I/O

Package Information (9, 10, 11, 12)



TOP VIEW



BOTTOM VIEW

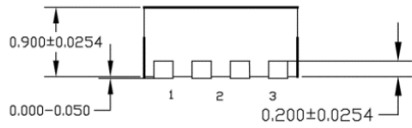

SIDE VIEW

- NOTE:
1. ALL DIMENSIONS ARE IN MILLIMETERS.
 2. MAX. PACKAGE WARPAGE IS 0.05 mm.
 3. MAXIMUM ALLOWABLE BURRS IS 0.076 mm IN ALL DIRECTIONS.
 4. PIN #1 ID ON TOP WILL BE LASER/INK MARKED.

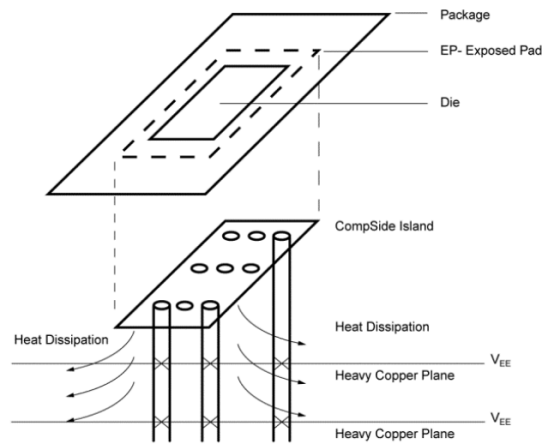

8-Pin 2mm × 2mm QFN Package

Note:

9. Package information is correct as of the publication date. For updates and most current information, go to www.micrel.com.
10. Package meets Level 1 qualifications.
11. All parts are dry packaged before shipment.
12. Exposed pads must be soldered to the most negative plane, equivalent to device V_{BB} , for proper thermal management.

MICREL, INC. 2180 FORTUNE DRIVE SAN JOSE, CA 95131 USATEL +1 (408) 944-0800 FAX +1 (408) 474-1000 WEB <http://www.micrel.com>

Micrel makes no representations or warranties with respect to the accuracy or completeness of the information furnished in this data sheet. This information is not intended as a warranty and Micrel does not assume responsibility for its use. Micrel reserves the right to change circuitry, specifications and descriptions at any time without notice. No license, whether express, implied, arising by estoppel or otherwise, to any intellectual property rights is granted by this document. Except as provided in Micrel's terms and conditions of sale for such products, Micrel assumes no liability whatsoever, and Micrel disclaims any express or implied warranty relating to the sale and/or use of Micrel products including liability or warranties relating to fitness for a particular purpose, merchantability, or infringement of any patent, copyright or other intellectual property right.

Micrel Products are not designed or authorized for use as components in life support appliances, devices or systems where malfunction of a product can reasonably be expected to result in personal injury. Life support devices or systems are devices or systems that (a) are intended for surgical implant into the body or (b) support or sustain life, and whose failure to perform can be reasonably expected to result in a significant injury to the user. A Purchaser's use or sale of Micrel Products for use in life support appliances, devices or systems is a Purchaser's own risk and Purchaser agrees to fully indemnify Micrel for any damages resulting from such use or sale.

© 2006 Micrel, Incorporated.