

# UM11309

## CLRC663ARD board quickstart guide

Rev. 1.0 — 3 February 2020

559910

User manual  
COMPANY PUBLIC

### Document information

Information	Content
Keywords	CLRC663
Abstract	Description of CLRC663ARD board



Revision history		
Rev	Date	Description
1.0	20200203	First release

## 1 Introduction

The purpose of this document is to describe how to use CLEV663ARD board. It provides an easy way to evaluate NFC features.

## 2 Hardware Description

This chapter describes hardware parts of the CLRC663 *plus* based Arduino interface board.

### 2.1 CLRC6630ARD board

CLEV663ARD add-on board provides NFC reader functionality and it is designed to be used with any boards compatible with Arduino header, including most LPCXpresso, Kinetis and i.MX boards.

Figure below shows the board and main components.

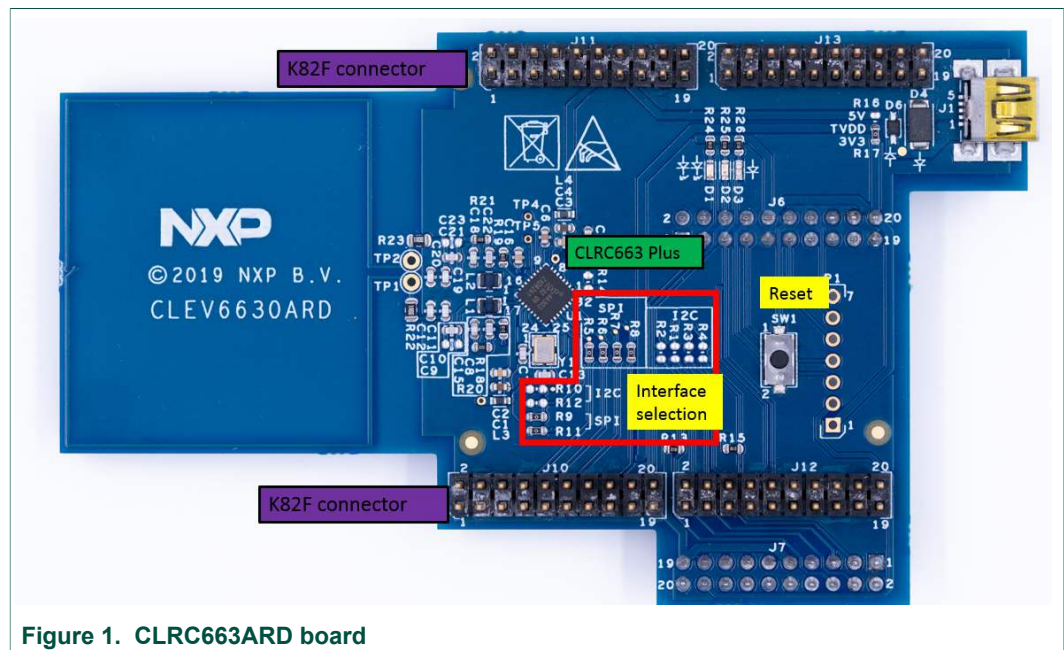

Figure 1. CLRC663ARD board

### 2.2 Interface selection

CLEV663ARD add-on board provides SPI and I<sup>2</sup>C host interface connections. The table below shows the configuration for SPI and I<sup>2</sup>C interface. The default interface is SPI (marked in Green in below table).

Table 1. Interface selection

Resistor	SPI	I <sup>2</sup> C
R1	open	0 Ohm (closed)
R2	open	0 Ohm (closed)
R3	open	0 Ohm (closed)
R4	open	0 Ohm (closed)

Resistor	SPI	I <sup>2</sup> C
R5	0 Ohm (closed)	open
R6	0 Ohm (closed)	open
R7	0 Ohm (closed)	open
R8	0 Ohm (closed)	open
R9	0 Ohm (closed)	open
R10	open	0 Ohm (closed)
R11	0 Ohm (closed)	open
R12	open	0 Ohm (closed)

### 2.3 Schematics

The complete schematics of the CLEV663ARD add-on board are shown in following figures:

#### 2.3.1 Main Schematics

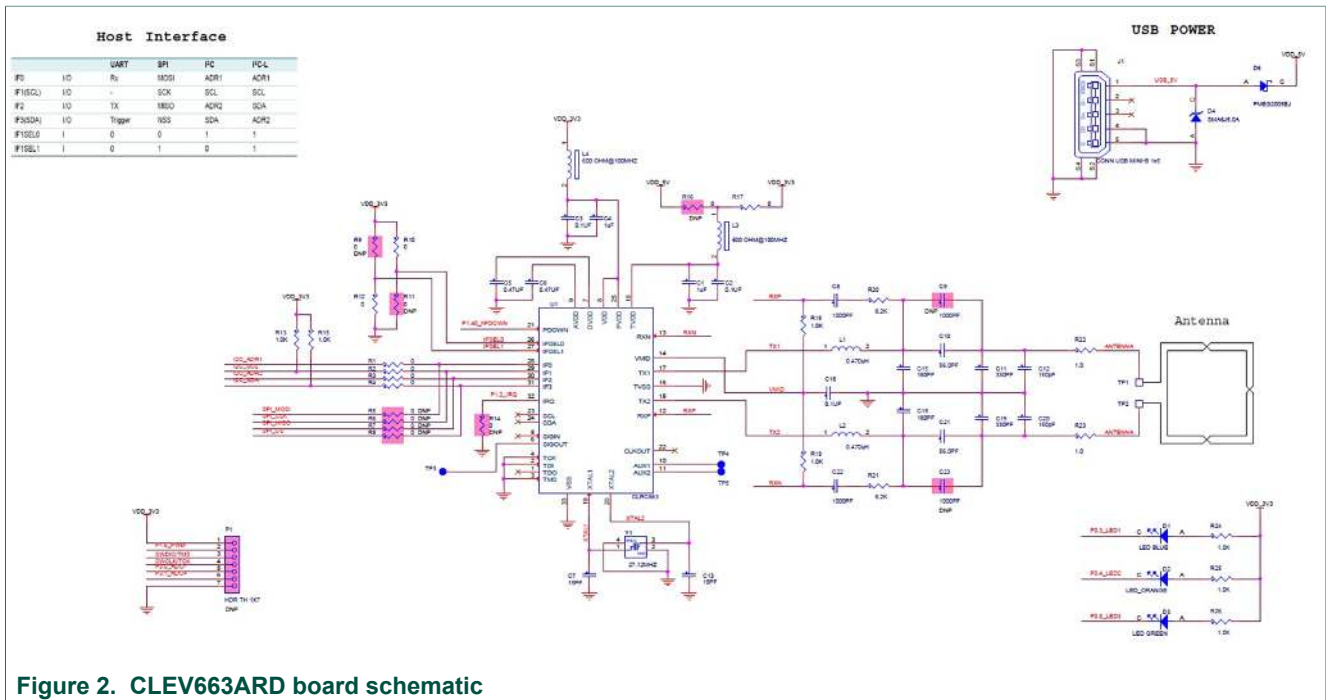
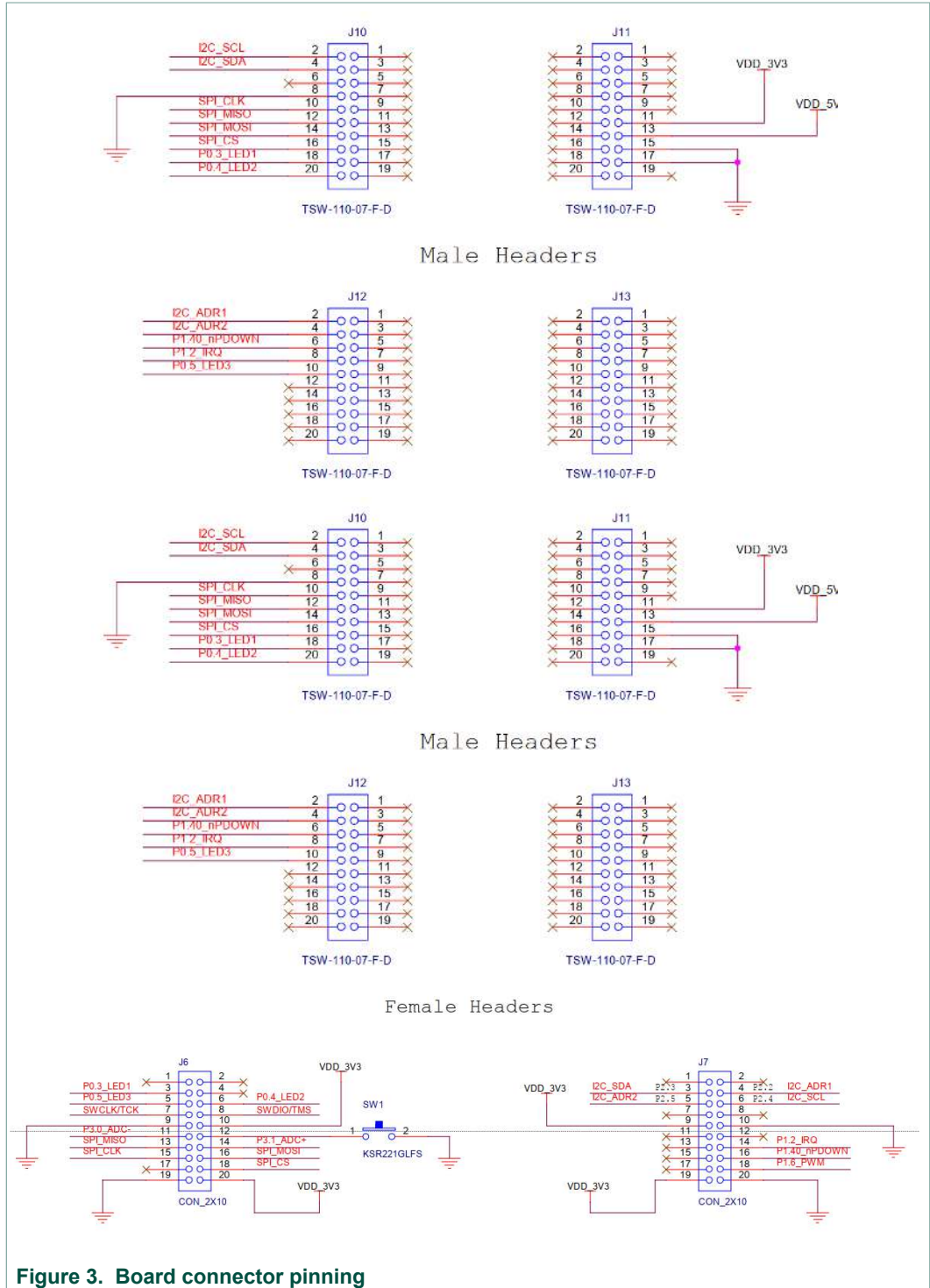

Figure 2. CLEV663ARD board schematic

2.3.2 Board connectors



### 3 Software

---

Following combinations have been tested

The software download (NFC Reader Library - Software support for NFC Frontend solutions) is available on [www.nxp.com](http://www.nxp.com)

Following boards can be used in combination with software package

- Kinetis K82F
- QN9020

Optional: (software not tested)

- connectors also fit for Arduino board

### 4 Reference documentation

---

#### 4.1 Data sheets

1. CLRC663 High performance multi-protocol NFC frontend CLRC663 and CLRC663 *plus*, Product data sheet, <https://www.nxp.com/docs/en/data-sheet/CLRC663.pdf>

## 5 Legal information

### 5.1 Definitions

**Draft** — The document is a draft version only. The content is still under internal review and subject to formal approval, which may result in modifications or additions. NXP Semiconductors does not give any representations or warranties as to the accuracy or completeness of information included herein and shall have no liability for the consequences of use of such information.

### 5.2 Disclaimers

**Limited warranty and liability** — Information in this document is believed to be accurate and reliable. However, NXP Semiconductors does not give any representations or warranties, expressed or implied, as to the accuracy or completeness of such information and shall have no liability for the consequences of use of such information. NXP Semiconductors takes no responsibility for the content in this document if provided by an information source outside of NXP Semiconductors. In no event shall NXP Semiconductors be liable for any indirect, incidental, punitive, special or consequential damages (including - without limitation - lost profits, lost savings, business interruption, costs related to the removal or replacement of any products or rework charges) whether or not such damages are based on tort (including negligence), warranty, breach of contract or any other legal theory. Notwithstanding any damages that customer might incur for any reason whatsoever, NXP Semiconductors' aggregate and cumulative liability towards customer for the products described herein shall be limited in accordance with the Terms and conditions of commercial sale of NXP Semiconductors.

**Right to make changes** — NXP Semiconductors reserves the right to make changes to information published in this document, including without limitation specifications and product descriptions, at any time and without notice. This document supersedes and replaces all information supplied prior to the publication hereof.

**Suitability for use** — NXP Semiconductors products are not designed, authorized or warranted to be suitable for use in life support, life-critical or safety-critical systems or equipment, nor in applications where failure or malfunction of an NXP Semiconductors product can reasonably be expected to result in personal injury, death or severe property or environmental damage. NXP Semiconductors and its suppliers accept no liability for inclusion and/or use of NXP Semiconductors products in such equipment or applications and therefore such inclusion and/or use is at the customer's own risk.

**Applications** — Applications that are described herein for any of these products are for illustrative purposes only. NXP Semiconductors makes no representation or warranty that such applications will be suitable for the specified use without further testing or modification. Customers are responsible for the design and operation of their applications and products using NXP Semiconductors products, and NXP Semiconductors accepts no liability for any assistance with applications or customer product design. It is customer's sole responsibility to determine whether the NXP Semiconductors product is suitable and fit for the customer's applications and products planned, as well as for the planned application and use of customer's third party customer(s). Customers should provide appropriate design and operating safeguards to minimize the risks associated with their applications and products. NXP Semiconductors does not accept any

liability related to any default, damage, costs or problem which is based on any weakness or default in the customer's applications or products, or the application or use by customer's third party customer(s). Customer is responsible for doing all necessary testing for the customer's applications and products using NXP Semiconductors products in order to avoid a default of the applications and the products or of the application or use by customer's third party customer(s). NXP does not accept any liability in this respect.

**Export control** — This document as well as the item(s) described herein may be subject to export control regulations. Export might require a prior authorization from competent authorities.

**Evaluation products** — This product is provided on an "as is" and "with all faults" basis for evaluation purposes only. NXP Semiconductors, its affiliates and their suppliers expressly disclaim all warranties, whether express, implied or statutory, including but not limited to the implied warranties of non-infringement, merchantability and fitness for a particular purpose. The entire risk as to the quality, or arising out of the use or performance, of this product remains with customer. In no event shall NXP Semiconductors, its affiliates or their suppliers be liable to customer for any special, indirect, consequential, punitive or incidental damages (including without limitation damages for loss of business, business interruption, loss of use, loss of data or information, and the like) arising out of the use of or inability to use the product, whether or not based on tort (including negligence), strict liability, breach of contract, breach of warranty or any other theory, even if advised of the possibility of such damages. Notwithstanding any damages that customer might incur for any reason whatsoever (including without limitation, all damages referenced above and all direct or general damages), the entire liability of NXP Semiconductors, its affiliates and their suppliers and customer's exclusive remedy for all of the foregoing shall be limited to actual damages incurred by customer based on reasonable reliance up to the greater of the amount actually paid by customer for the product or five dollars (US\$5.00). The foregoing limitations, exclusions and disclaimers shall apply to the maximum extent permitted by applicable law, even if any remedy fails of its essential purpose.

**Translations** — A non-English (translated) version of a document is for reference only. The English version shall prevail in case of any discrepancy between the translated and English versions.

### 5.3 Licenses

#### Purchase of NXP ICs with NFC technology

Purchase of an NXP Semiconductors IC that complies with one of the Near Field Communication (NFC) standards ISO/IEC 18092 and ISO/IEC 21481 does not convey an implied license under any patent right infringed by implementation of any of those standards. Purchase of NXP Semiconductors IC does not include a license to any NXP patent (or other IP right) covering combinations of those products with other products, whether hardware or software.

### 5.4 Trademarks

Notice: All referenced brands, product names, service names and trademarks are the property of their respective owners.

---

## Tables

---

Tab. 1. Interface selection ..... 3

## Figures

---

Fig. 1. CLRC663ARD board .....3      Fig. 3. Board connector pinning ..... 5  
Fig. 2. CLEV663ARD board schematic .....4



## Contents

---

<b>1</b>	<b>Introduction .....</b>	<b>3</b>
<b>2</b>	<b>Hardware Description .....</b>	<b>3</b>
2.1	CLRC6630ARD board .....	3
2.2	Interface selection .....	3
2.3	Schematics .....	4
2.3.1	Main Schematics .....	4
2.3.2	Board connectors .....	5
<b>3</b>	<b>Software .....</b>	<b>6</b>
<b>4</b>	<b>Reference documentation .....</b>	<b>6</b>
4.1	Data sheets .....	6
<b>5</b>	<b>Legal information .....</b>	<b>7</b>

---

Please be aware that important notices concerning this document and the product(s) described herein, have been included in section 'Legal information'.

---

© NXP B.V. 2020.

All rights reserved.

For more information, please visit: <http://www.nxp.com>

For sales office addresses, please send an email to: [salesaddresses@nxp.com](mailto:salesaddresses@nxp.com)

Date of release: 3 February 2020

Document identifier: UM11309

Document number: 559910