

PART NUMBER IN TAPE/REEL	CKT. SIZE	VOID CKT.	DIM A	DIM B
87368-8010	20	5	20.20/0.795	18.00/0.709

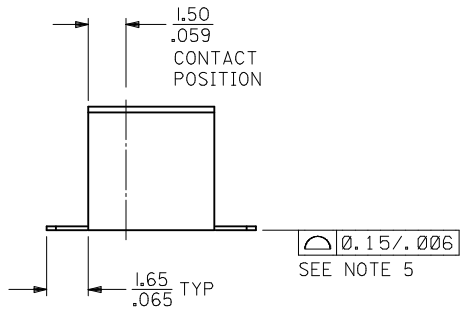

- NOTE:**
- MATERIAL : HOUSING - NYLON, GLASS FILLED, UL94 V-0
COLOR : BLACK
TERMINAL - PHOSPHOR BRONZE
 - FINISHES : TERMINAL - SELECTIVE GOLD IN THE CONTACT AREA
2.54um/100uin MIN. SELECTIVE TIN
IN THE PC TAIL AREA
BOTH OVER 1.27um/50uin MIN. NICKEL OVERALL
 - PRODUCT SPECIFICATION : PS-87264
 - COPLANARITY OF SOLDER TAIL IS TO BE MEASURED BY RESTING THE PART ON A FLAT GAUGE SURFACE.
 - PART MATEABLE TO ALL MILLI-GRID HEADERS WITH MATING PIN LENGTH BETWEEN 2.50mm AND 4.20mm
 - PART IS PACK IN TAPE/REEL.
 - PARTS SHALL BE PACKED IN MOISTURE BARRIER BAG.

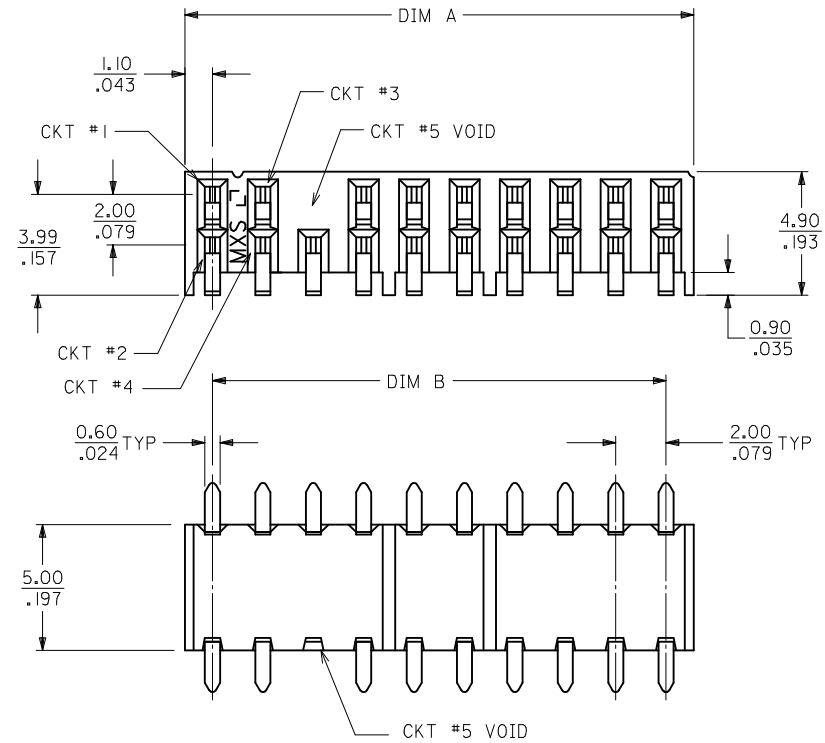
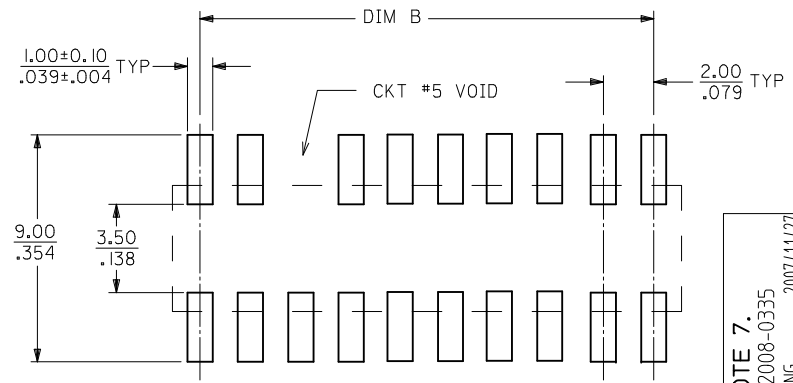

RECOMMENDED P.C. BOARD LAYOUT

ADD NOTE 7. EC NO: S2008-0335 DRWN:SKANG 2007/11/27 CHKD:ATSEE 2007/11/30 APPR:MLONG 2007/12/03	QUALITY SYMBOLS ▽=0 ◻=0	GENERAL TOLERANCES (UNLESS SPECIFIED)		DIMENSION STYLE	SCALE	DESIGN UNITS	THIRD ANGLE PROJECTION	
		mm	INCH	MM/IN	NTS	METRIC		
		4 PLACES ± --- ± ---		DRAWN BY	DATE	TITLE		
		3 PLACES ± --- ± .008		KSEE	2003/05/08	MGRID SIDE ENTRY RECEPTACLE WITH VOID, SMT		
2 PLACES ± 0.20 ± ---		CHECKED BY	DATE					
1 PLACE ± --- ± ---		KCLING	2003/06/18	MOLEX INCORPORATED				
ANGULAR ± 3 °		APPROVED BY	DATE					
		SKTOH	2003/06/18	MATERIAL NO.	DOCUMENT NO.	SHEET NO.		
		DRAFT WHERE APPLICABLE MUST REMAIN WITHIN DIMENSIONS		SEE TABLE	SD-87368-005	1 OF 2		
		SIZE	THIS DRAWING CONTAINS INFORMATION THAT IS PROPRIETARY TO MOLEX INCORPORATED AND SHOULD NOT BE USED WITHOUT WRITTEN PERMISSION					
		A3						

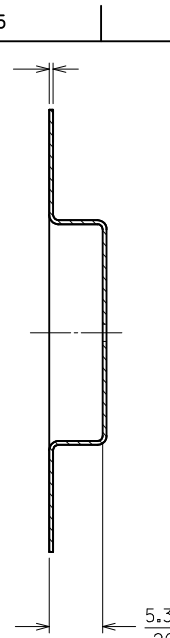
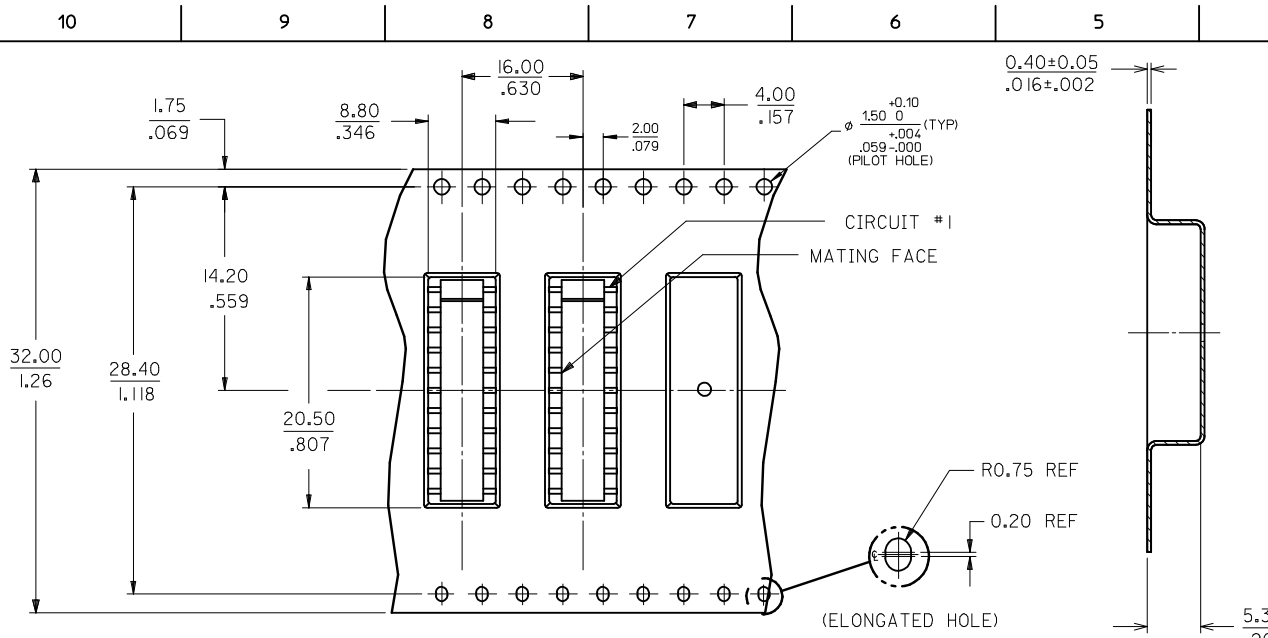

NOTES:

- LEADER AND TRAILER TAPE
- PEELING OFF FORCE OF THE TOP TAPE: 20-80gf.
 (PEELING DIRECTION AS SHOWN IN FOLLOWING FIGURE)
- PACKAGING STANDARD IS AS PER EIA-481.
- TAPE & REEL QUANTITY = 750PCS/REEL

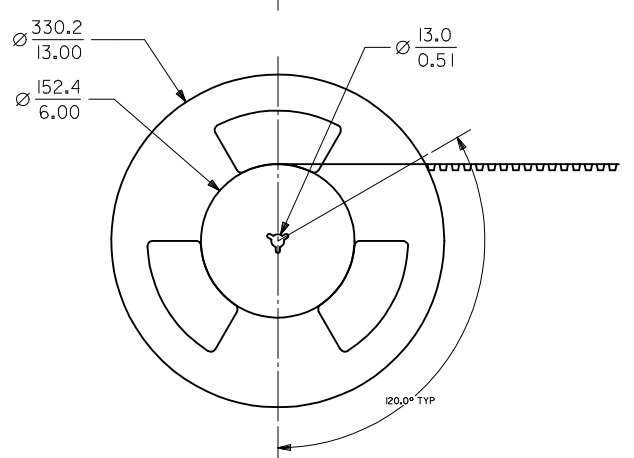
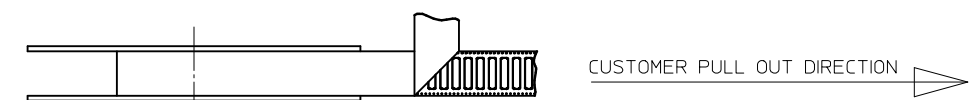

TAPE AND REEL ORIENTATION
 (NOT TO SCALE AND 22 CKT SHOWN
 FOR ILLUSTRATION ONLY)

ADD NOTE 7. EC NO: S2008-0335 DRWN:SKANG 2007/11/27 CHYKD:ATSEE 2007/11/30 APPR:MLONG 2007/12/03	QUALITY SYMBOLS ▽=0 ◻=0	GENERAL TOLERANCES (UNLESS SPECIFIED) <table border="1"> <tr> <td></td> <td>mm</td> <td>INCH</td> </tr> <tr> <td>4 PLACES</td> <td>± ---</td> <td>± ---</td> </tr> <tr> <td>3 PLACES</td> <td>± ---</td> <td>± .008</td> </tr> <tr> <td>2 PLACES</td> <td>± 0.20</td> <td>± ---</td> </tr> <tr> <td>1 PLACE</td> <td>± ---</td> <td>± ---</td> </tr> </table>		mm	INCH	4 PLACES	± ---	± ---	3 PLACES	± ---	± .008	2 PLACES	± 0.20	± ---	1 PLACE	± ---	± ---	DIMENSION STYLE MM/IN	SCALE NTS	DESIGN UNITS METRIC	THIRD ANGLE PROJECTION
		mm	INCH																		
	4 PLACES	± ---	± ---																		
	3 PLACES	± ---	± .008																		
2 PLACES	± 0.20	± ---																			
1 PLACE	± ---	± ---																			
D1	DESCRIPTION	ANGULAR ± 3 °	DRAWN BY KSEE	DATE 2003/05/08	TITLE MGRID SIDE ENTRY RECEPTACLE WITH VOID, SMT																
		DRAFT WHERE APPLICABLE MUST REMAIN WITHIN DIMENSIONS	CHECKED BY KCLING	DATE 2003/06/18	MOLEX INCORPORATED																
			APPROVED BY SKTOH	DATE 2003/06/18	MATERIAL NO. SEE TABLE	DOCUMENT NO. SD-87368-005															