

HOA1885

Transmissive Sensor

FEATURES

- Choice of phototransistor or photodarlington output
- High profile package for raised optical centerline
- Ambient light and dust protective filter
- 0.200 in.(5.08 mm) slot width

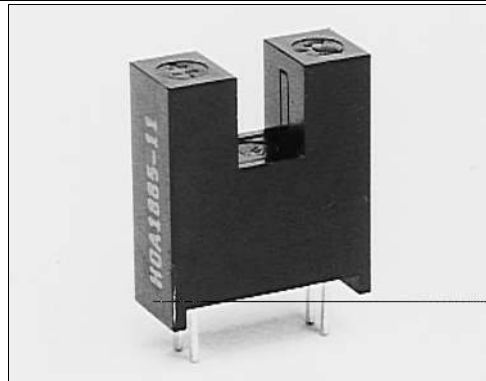

INFRA-69.TIF

DESCRIPTION

The HOA1885 series consists of an infrared emitting diode facing an NPN silicon phototransistor (HOA1885-011, -012) or photodarlington (HOA1885-013) encased in a black thermoplastic housing with IR transmissive inserts which form the optical windows. This arrangement provides excellent protection against ambient light while eliminating aperture openings which could be clogged by airborne contaminants. The high profile package raises the optical centerline to a nominal height of 0.063 in.(16.0 mm) from the mounting plane. This is a significant feature for applications in which surrounding components might interfere with the interrupting element if the optical centerline were lower. Detector switching takes place whenever an opaque object passes through the slot between emitter and detector. The HOA1885 series employs plastic molded components and has a 0.050 in.(1.27 mm) x 0.060 in.(1.52 mm) vertical aperture in front of the detector. For additional component information see SEP8506/8706, SDP8406, and SDP8106.

Housing material is polycarbonate. Housings are soluble in chlorinated hydrocarbons and ketones. Recommended cleaning agents are methanol and isopropanol.

OUTLINE DIMENSIONS in inches (mm)

Tolerance 3 plc decimals $\pm 0.010(0.25)$
 2 plc decimals $\pm 0.020(0.51)$

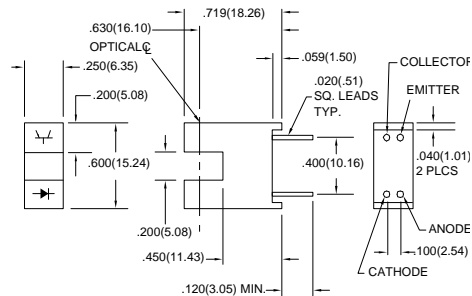

DIM_055.ds4

HOA1885

Transmissive Sensor

ELECTRICAL CHARACTERISTICS (25°C unless otherwise noted)

PARAMETER	SYMBOL	MIN	TYP	MAX	UNITS	TEST CONDITIONS
IR EMITTER						
Forward Voltage	V_F			1.6	V	$I_F=20\text{ mA}$
Reverse Leakage Current	I_R			10	μA	$V_R=3\text{ V}$
DETECTOR						
Collector-Emitter Breakdown Voltage HOA1885-011, -012 HOA1885-013	$V_{(BR)CEO}$	30 15			V	$I_C=100\ \mu\text{A}$
Emitter-Collector Breakdown Voltage	$V_{(BR)ECO}$	5.0			V	$I_E=100\ \mu\text{A}$
Collector Dark Current HOA1885-011, -012 HOA1885-013	I_{CEO}			100 250	nA	$V_{CE}=10\text{ V}$ $I_F=0$
COUPLED CHARACTERISTICS						
On-State Collector Current HOA1885-011 HOA1885-012 HOA1885-013	$I_{C(ON)}$	0.3 1.8 4.0			mA	$V_{CE}=5\text{ V}$ $I_F=20\text{ mA}$
Collector-Emitter Saturation Voltage HOA1885-011 HOA1885-012 HOA1885-013	$V_{CE(SAT)}$			0.4 0.4 1.1	V	$I_F=20\text{ mA}$ $I_C=40\ \mu\text{A}$ $I_C=230\ \mu\text{A}$ $I_C=500\ \mu\text{A}$
Rise And Fall Time HOA1885-011, -012 HOA1885-013	t_r, t_f			15 75	μs	$V_{CC}=5\text{ V}, I_C=1\text{ mA}$ $R_L=1000\ \Omega$ $R_L=100\ \Omega$

ABSOLUTE MAXIMUM RATINGS

(25°C Free-Air Temperature unless otherwise noted)

Operating Temperature Range	-40°C to 85°C
Storage Temperature Range	-40°C to 85°C
Soldering Temperature (5 sec)	240°C

IR EMITTER

Power Dissipation	100 mW ⁽¹⁾
Reverse Voltage	3 V
Continuous Forward Current	50 mA

DETECTOR

Collector-Emitter Voltage	30 V
Emitter-Collector Voltage	5 V
Power Dissipation	100 mW ⁽¹⁾

Notes

- Derate linearly at 0.78 mW/°C above 25°C.

SCHEMATIC

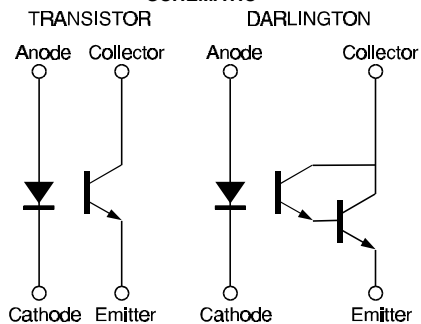

Honeywell reserves the right to make changes in order to improve design and supply the best products possible.

Honeywell

HOA1885

Transmissive Sensor

Fig. 1 IRED Forward Bias Characteristics

gra_092.ds4

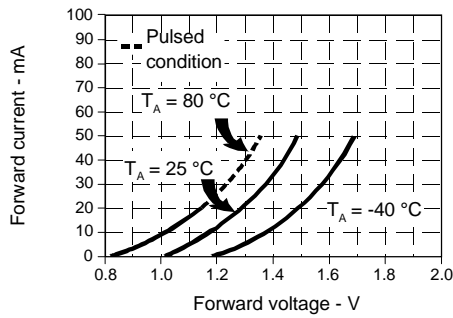

Fig. 2 Non-Saturated Switching Time vs Load Resistance

gra_096.ds4

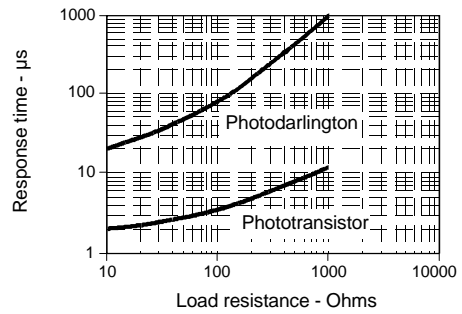

Fig. 3 Dark Current vs Temperature

gra_301.cdr

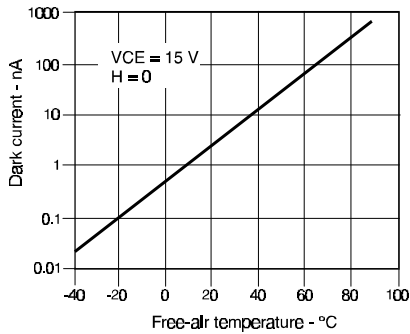
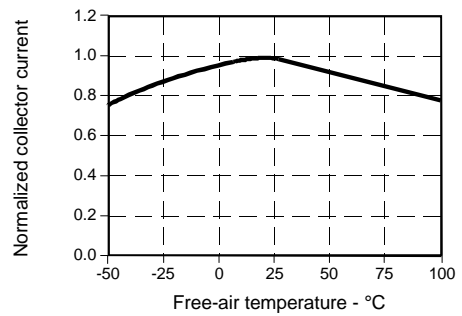

Fig. 4 Collector Current vs Ambient Temperature

gra_095.ds4



All Performance Curves Show Typical Values

HOA1885
Transmissive Sensor

Honeywell reserves the right to make changes in order to improve design and supply the best products possible.

Honeywell

333