

OV493 companion ISP product brief



available in
a lead-free
package

Cost-Effective Surround-View Image Processing Solution for Automotive Applications

OmniVision's OV493 is a compact image signal processor (ISP) companion chip that brings best-in-class image quality to 360-degree surround-view and video mirror imaging applications. By processing two video streams simultaneously, the OV493 makes it possible for a system with only two ISP companion chips to process four camera inputs, enabling flexible electronic control unit (ECU) designs for surround-view applications and dramatically reducing overall system cost.

While most ISP companion chips are located on the camera module, the OV493 can be placed on the ECU module for unprecedented flexibility and streamlined

system architectures. The OV493 is designed to work seamlessly with OmniVision's high-performance OV9716 and OV10640 automotive image sensors, supporting dual sensor input of up to 1.4 megapixels at 30 frames per second (fps) with high dynamic range (HDR) each.

The OV493 comes in an AEC-Q100 Grade 2 qualified 7 x 7 mm ball grid array (BGA) package.

Find out more at www.ovt.com.



Applications

- Surround view system
- Camera Monitoring System (CMS)
- E-Mirror

Product Features

- AEC-Q100 grade 2 qualified
- advanced 100 Mp/s throughput ISP for high quality image capturing and video streaming
- local and global tone mapping support
- up to 3-capture HDR combination
- simultaneous output of fully processed YUV for display-based applications and RAW for machine vision applications
- embedded information including frame counter, temperature, and register data for each image to enable critical automotive safety applications
- auto white balance (AWB)
- automatic exposure control (AEC) / automatic gain control (AGC)
- supports statistics data of up to four user programmable ROIs
- SCCB master/slave interface for sensor and ASIC configuration
- supports four-wire or two-wire serial interface to retrieve stored firmware from external memory devices, such as EEPROM
- on-chip PLL to generate internal clocks
- on-chip voltage regulator 1.8V to 1.1V
- brown-out detection circuit and output flag
- supports 2x2 lane MIPI RX/TX and 1x4 lane MIPI RX/TX
- supports 12-bit DVP input, shared with MIPI RX (1.0 Gbps/lane)
- supports 12-bit DVP output, shared with MIPI TX
- supports 24-bit DVP output, shared with BT1120 output
- embedded 32-bit RISC processor for high performance and flexibility
- supports 1K bits of one-time programmable memory (OTP)
- JTAG boundary scan

OV493

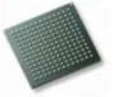

Ordering Information

- OV00493-B69G-1B** (lead-free)
169-pin BGA, packed in tray
- OV00493-B69G-TB** (lead-free)
169-pin BGA, packed in tape and reel

Product Specifications

- power supply:**
 - core: 1.1V ±5%
 - I/O: 1.8V ±5% or 3.3V ±5%
- power requirements:** 265 mW, measured at 1392 x 976 @ 30 fps, 12-bit plus 12-bit input from OV9716 via MIPI interface and 1392 x 976 YUV422 output via MIPI interface
- temperature range:**
 - operating: -40°C to +105°C ambient temperature and -40°C to +125°C junction temperature
- package dimensions:** 7 mm x 7 mm

Advanced Architecture Example

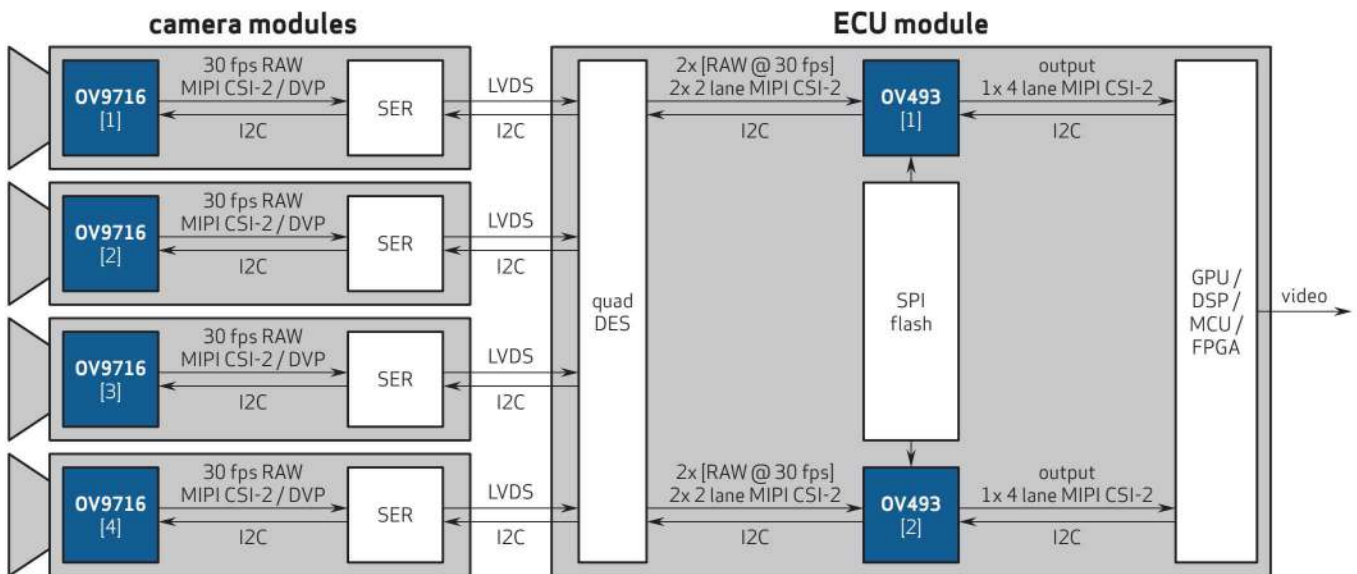

4275 Burton Drive
Santa Clara, CA 95054
USA

Tel: +1 408 567 3000
Fax: +1 408 567 3001
www.ovt.com

OmniVision reserves the right to make changes to their products or to discontinue any product or service without further notice. OmniVision and the OmniVision logo are registered trademarks of OmniVision Technologies, Inc. All other trademarks are the property of their respective owners.



OmniVision