

PART NUMBER	REV	FIRST USED
567882-1	A	854040-3

AMP P/N		MFG P/N		VISIBLE PAD LTR	CRIMP DATA (NON-AMP TERM-CUST SPEC)	
286881		7114-4100-08			CRIMP HEIGHT	WIRE SIZE
				A	.045 ±.001 [1.15 ±0.03mm]	20
				B	NOT	USED
				C	NOT	USED
				D	NOT	USED
					CRIMP SIZE	TYPE
					.065 [1.65mm]	F
					INSUL	OV
					.086 [2.18mm]	1.7mm-1.85mm
WIRE STRIP LENGTH	TERM APPL SPEC	FEED	APPL INSTRUCTION	SET UP GAGE	LAYOUT	
.195-.212	NONE	.362	SEE CUSTOMER MANUAL	NONE	L2443	

STANDARD FORCE CRIMP QUALITY MONITOR APPLICATOR
SIM TO HDM NONE

QTY	REV	U/M	DWG SIZE	PART NO	DESCRIPTION	ITEM NO
1	-	A		2-21010-7	SCR, SET (6-32x.12) LIFT ARM	67
1	-	B		1-21002-6	SCR, BHC (6-32x.25) LEVER	66
1	-	B		856044-1	LEVER, SLIDE LOCK	65
1	-	A		2-21000-0	SCR, SHC (6-32x.50) LIFT ARM	64
1	-	B		856043-1	ARM, LIFT	63
1	-	A		2-21000-6	SCR, SHC (8-32x.38) EXT ARM	62
1	-	B		856042-1	ARM, EXTENSION	61
						60
						59
						58
1	-	A		7-21013-3	SCR, SET (5/16x.38) CR BOLT	57
REF	-	B		694433-8	PAWL, FEED	56
						55
						54
						53
						52
1	-	A		811242-2	BUMPER, HOLDDOWN	51
1	-	A		690753-1	SPACER, TONKER	50
						49
1	-	A		690602-6	CAM, PRE-FEED 1.62 STROKE	48
						47
						46
1	-	A		690191-1	PLUG, NYLON	45
1	-	C		853493-4	SIDE FEED RAM ASSY	44
1	-	A		690125-1	WASHER, LAMINATED	43
1	-	A		690124-1	WASHER, RAM	42
1	-	A		7-21002-9	BOLT, CRIMPER (5/16x1.00)	41
1	-	A		23241-6	BALL, STEEL	40
1	-	A		690170-1	SPRING, COMPRESSION	39
1	-	C		690142-1	DISC, INSULATION	38
1	-	D		354777-1	WIRE DISC, PLASTIC	37
1	-	A		22480-5	WASHER, SPRING	36
1	-	B		856041-1	POST, RAM	35
1	-	B		690786-1	SUPPORT, TERMINAL	34
1	-	C		462544-1	PLATE, BASE SPECIAL	33
1	-	A		690432-3	SCREW, ADJUSTMENT	32
1	-	B		462543-1	BLOCK, SCREW SPECIAL	31
1	-	B		455689-1	BLOCK, STRIP GUIDE ADJ	30
1	-	C		1-458144-7	PLATE, STRIP GUIDE	29
1	-	C		1-455888-0	SPACER, FRONT SHEAR DEP	28
2	-	A		1-22284-0	SPRING, DRAG	27
1	-	B		240793-1	LEVER, DRAG RELEASE	26
1	-	B		217233-1	DRAG, TERMINAL	25
1	-	D		90765-4	GUIDE, STRIP (REAR)	24
1	-	A		2-690487-0	GUIDE, STRIP (FRONT)	23
						22
1	-	A		463756-1	GUIDE, SCRAP	21
						20
1	-	C		904458-3	STRIPPER	19
						18
						17
						16
						15
						14
						13
1	-	A		5-22280-0	SPRING, SHEAR	12
1	-	B		1-690461-6	STOP, SHEAR (FRONT)	11
1	-	B		462548-1	HOLDER, SHEAR (FRONT) SP	10
1	-	B		462547-5	SHEAR, FLOAT (FRONT) SP	9
1	-	C		1-318711-2	ANVIL	8
1	-	C		2-240641-0	SPACER, DEPRESSOR (REAR)	7
						6
1	-	A		462838-1	DEPRESSOR, SHEAR (FRONT) SP	5
1	-	B		1-238011-7	SPACER, BLOCK CRIMPER	4
1	-	C		2-854830-6	CRIMPER, INSULATION	3
1	-	C		455888-8	SPACER, CRIMPER	2
1	-	C		7-458141-6	CRIMPER, WIRE	1

QTY	REV	U/M	DWG SIZE	PART NO	DESCRIPTION	ITEM NO
2	-	C		5-354779-0	PIN, WIRE DISC (.3240)C	129
						128
						127
						126
1	-	A		986950-1	WASHER, FLAT PRECISION	125
1	-	A		217238-4	DOCUMENTATION PACKAGE	124
						123
						122
1	-	A		4-21028-0	PIN, SLT SPR (Ø.093x.75) ST 60E PL	121
1	-	B		690701-2	PLATE, SERIAL NO.	120
2	-	A		21899-2	WASHER, FLAT (#10) 5 G ADJ BLK	119
						118
2	-	A		21024-5	WASHER, LOCK (#10) ADJ BLOCK	117
						116
						115
2	-	A		21024-2	WASHER, LOCK (#4) FRONT STP GUIDE	114
REF	-	A		21024-4	WASHER, LOCK (#8) FEED FINGER	113
2	-	A		21024-4	WASHER, LOCK (#8) DEP-HOLD	112
REF	-	A		21024-4	WASHER, LOCK (#8) STRIPPER	111
						110
						109
1	-	A		21018-5	NUT, HEX (#6) HOLD DOWN	108
						107
						106
1	-	A		22353-8	SCR, SHLD (Ø.187x.25) DRAG LEVER	105
						104
1	-	A		21009-2	SCR, SKT 5ET (1/4-20x.25 LW) RAM	103
						102
4	-	A		21017-2	SCR, DRIVE (#2x.19) ID PLATE	101
1	-	B		819347-1	PLATE, IDENTIFICATION	100
2	-	A		3-21002-0	SCR, BHC (10-32x.88) DRAG	99
1	-	A		22733-8	SCR, BHC (8-32x.38 LW) ANVIL	98
						97
1	-	A		3-21000-8	SCR, SHC (10-32x.88) MOUNTING	96
1	-	A		2-21002-7	SCR, BHC (10-32x.50) 5G ADJ BLK	95
6	-	A		2-21002-2	SCR, BHC (8-32x.50) SHEAR-TERM SUP	94
						93
						92
1	-	A		1-21002-7	SCR, SHC (6-32x.50) CAM	91
2	-	A		2-21000-7	SCR, SHC (8-32x.50) SCR BLK	90
						89
						88
2	-	A		2-21000-7	SCR, SHC (8-32x.48) DEP-HOLD DOWN	87
REF	-	A		2-22603-0	SCR, HEX HD (8-32x.31) FEED FINGER	86
2	-	A		1-21000-3	SCR, SHC (4-40x.25) F ST GUIDE	85
REF	-	A		22733-9	SCR, BHC (8-32x.50 SL) STRIPPER	84
						83
						82
1	-	A		3-22603-1	SCR, HEX (10-32x.38) 5G ADJ BL	81
						80
						79
						78
2	-	B		463310-5	BLADE, STRIPPING (#20)	77
-	-	D		354440-3	FFC LOOP ASSY	76
						75
1	-	A		690603-1	SPRING, ASSIST	74
1	-	A		23030-1	SCR, SKT CAP (6-32x.25) CP DSC	73
						72
2	-	B		853495-1	GASKET	71

QTY	REV	U/M	DWG SIZE	PART NO	DESCRIPTION	ITEM NO
-1	U/M					

QTY	REV	U/M	DWG SIZE	PART NO	DESCRIPTION	ITEM NO
-1	U/M					

THIS DRAWING IS A CONTROLLED DOCUMENT.

THIS DRAWING IS UNRELEASED. RELEASE FOR PUBLICATION BY AMP INCORPORATED. ALL RIGHTS RESERVED. COPYRIGHT 19

LOC A
DIST 66

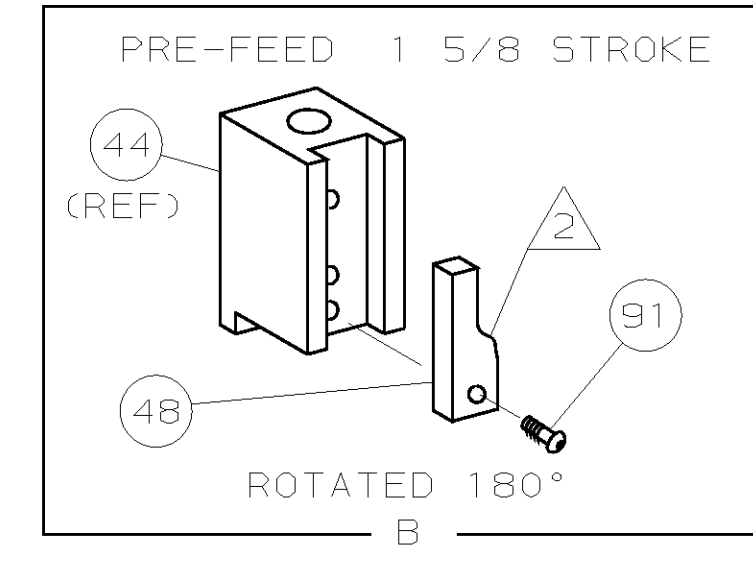

- 1 RECOMMENDED SPARE PARTS.
- 2 GREASE LIGHTLY.
- 3 ITEM NOT SHOWN
- 4 CUT TO LENGTH AT ASSY
- 5 CRIMP WIDTH IS .0688 +/- .001 AND IS MEASURED AT THE BOTTOM EDGES OF TERMINAL.

4 TORQUE ITEM 41 TO 60 INCH POUNDS

DIMENSIONS IN INCHES. DO NOT SCALE PRINT. TOLERANCES UNLESS OTHERWISE SPECIFIED:		MACH REF STRIPPER CRIMPER	
DR B.HIGMAN	APP T.ELBIN	AMP Incorporated Harrisburg, PA 17105-3608	
CHK B.HIGMAN	REL -	NAME CQM STRIPPER CRIMPER APPLICATOR	
3 PLC DEC ±	4 PLC DEC ±	SCALE -	DWG NO 567882
ANGLES ±	SURF TEXTURE: ✓	REMOVE BURRS, BREAK SHARP EDGES R.015 MAX	SHEET 1 OF 1
A2 ECN 0150-1036-04	TE 8-04	REVISION RECORD	REV A2
A1 ECN 0150-0547-03	TE 5-03		
A REVISED	BH 10/00		
P/F LTR	APP DATE		

CASE CODE 00779 CUSTOMER AND ASSEMBLY DRAWING