

GT10 Series

— ECU Interface Connectors —

<2 mm Pitch>

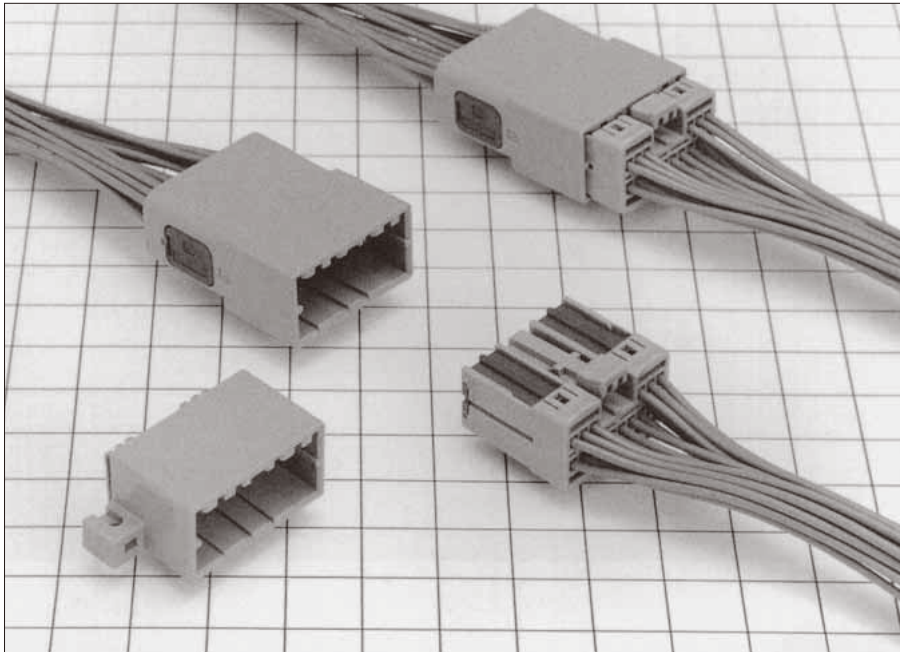

■ Features

- Usable with existing 040 connectors.
- Front retainer design prevents incomplete insertion.

F Connectors

● Terminal

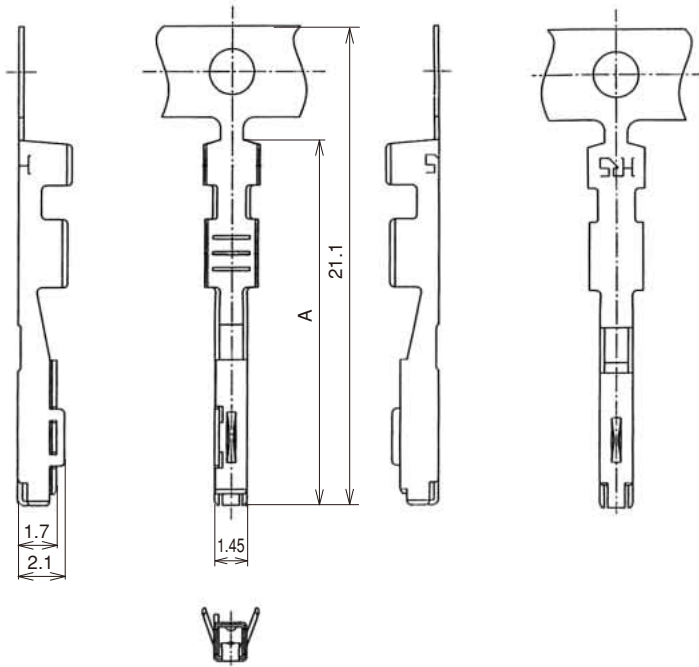
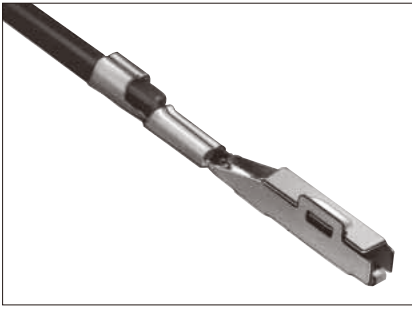

Part No.	HRS No.	Material	Plating	Conductor Size (AWG)	Outer Diameter	A Dimension	Packaging	RoHS
GT10-2022SCF	760-0003-0	Copper palloy	Tin plating	20 to 22 AWG	ϕ 1.1 to 1.3	16.1	10,000 pcs/reel	YES
GT10-2428SCF	760-0009-6			24 to 28 AWG	ϕ 0.8 to 1.1	15.1		

● Housing (with Retainer Provisionally Mounted)

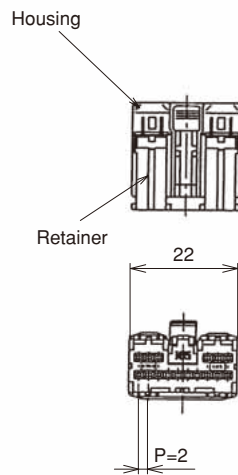

◆ Retainer assembled.

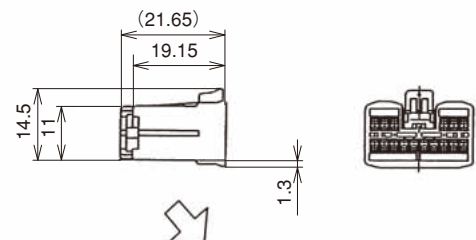

◆ Retainer assembled.

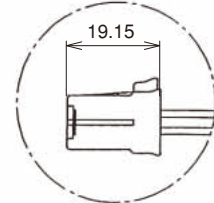

Part No.	HRS No.	Material/Plating or Color	Packaging	RoHS
GT10-16DS-HU	760-0002-7	Housing: PBT / Light Gray Retainer: PBT / Dark Gray	1	YES

Note: This product has the retainer provisionally mounted to the housing.
To use, fully mount the retainer at the specified position after the terminals have been inserted.

- GT5
- GT13
- GT16
- PO5G
- GT19
- GT21
- GT26
- GT36
- GT11
- GT17
- GT32
- GT3
- GT7
- GT10**
- GT18W
- GT25
- GT8E
- GT9
- GT15

GT10S Series with cover case

● Housing

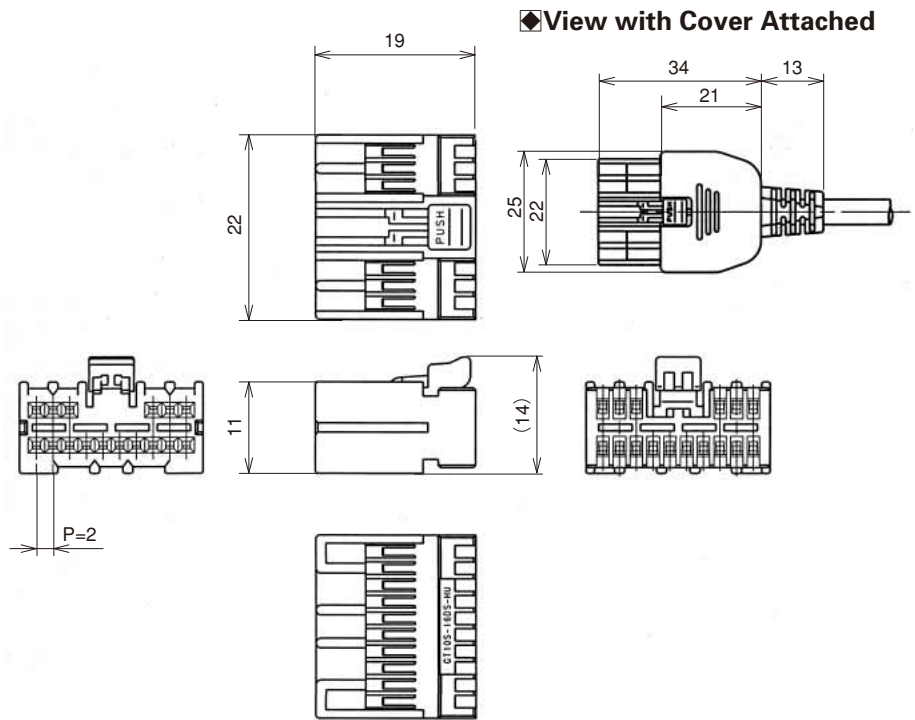
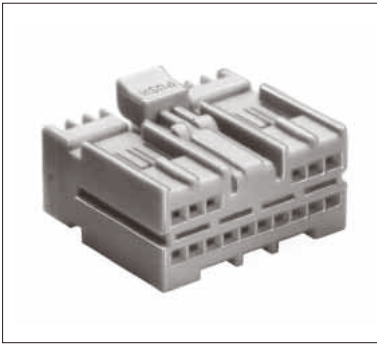

Part No.	HRS No.	Color	Material	Packaging	RoHS
GT10S-16DS-HU	760-0007-0	Light Gray	PBT	1	YES

Note: This product should be used with the cover attached to the housing.

● Cover

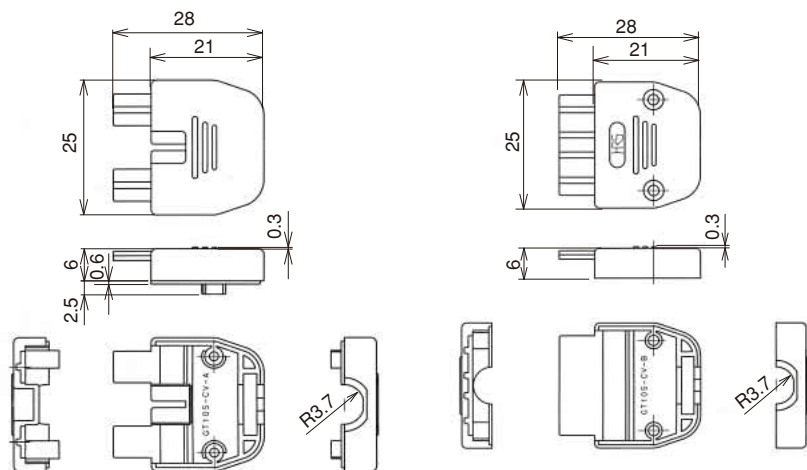

Cover A

Cover B

Part No.	HRS No.	Color	Material	Packaging	RoHS
GT10S-16DS-CV	760-0008-3	Black	PC	1	YES

Note 1 : This product can be used with cables having outside diameters of 4, 4.8, and 5.2 mm.

Please use as a set in conjunction with clamp fittings and bushings that suit the cable.

Note 2 : This product is sold as a set with cover A, B, and screws.

● Clamp Fittings

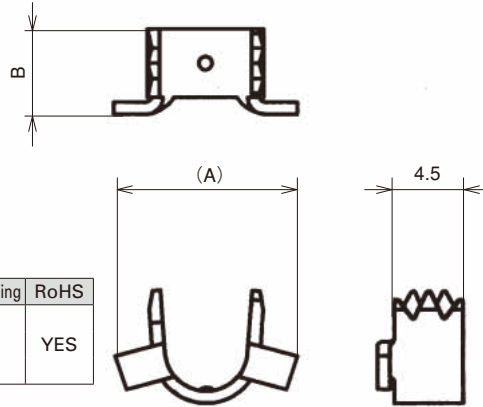
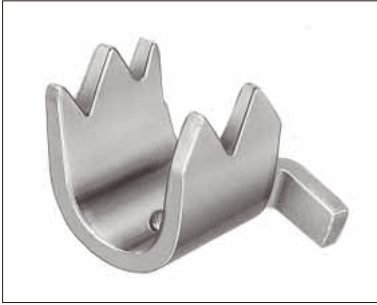

Part No.	HRS No	Material	A Dimension	B Dimension	Outer diameter of the cable	Packaging	RoHS
MQ138-CM (4.0)	206-0891-7	Brass	9	5.5	φ 4.0	1	YES
MQ138-CM (4.8)	206-0684-2		11.3	5.6	φ 4.8		
MQ138-CM (5.2)	206-0664-5		12	5.6	φ 5.2		

● Bushings

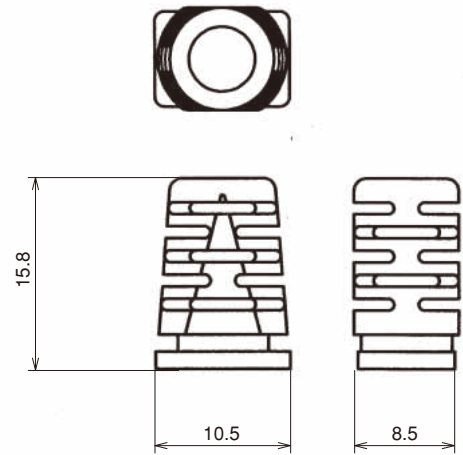

Part No.	HRS No.	Color	Material	Outer diameter of the cable	Packaging	RoHS
MQ138-BS (4.0) (01)	206-0890-4 01	Black	PCV	φ 4.0	1	YES
MQ138-BS (4.8) (01)	206-0683-0 01			φ 4.8		
MQ138-BS (5.2) (01)	206-0662-0 01			φ 5.2		

Aug. 1.2023 Copyright 2023 HIROSE ELECTRIC CO., LTD. All Rights Reserved.

- GT5
- GT13
- GT16
- PO5G
- GT19
- GT21
- GT26
- GT36
- GT11
- GT17
- GT32
- GT3
- GT7
- GT10**
- GT18W
- GT25
- GT8E
- GT9
- GT15

GT5

GT13

GT16

PO5G

GT19

GT21

GT26

GT36

GT11

GT17

GT32

GT3

GT7

GT10

GT18W

GT25

GT8E

GT9

GT15

M Connectors

● Terminal

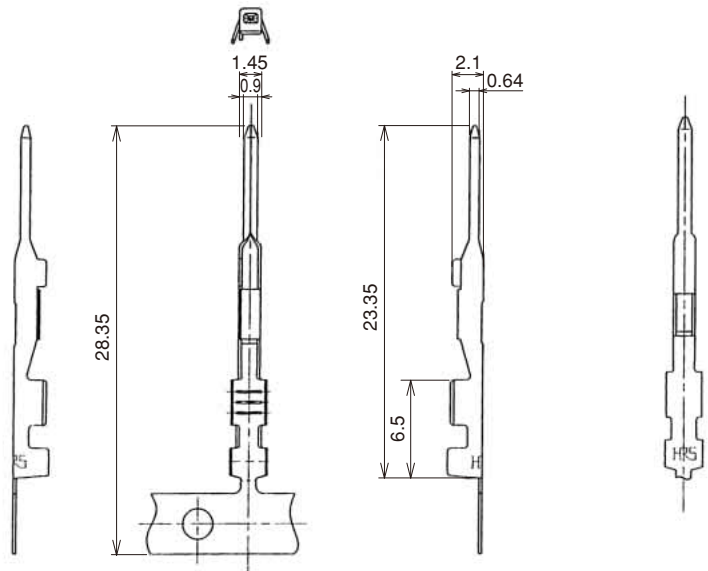

Part No.	HRS No.	Material	Plating	Conductor Size (AWG)	Outer Diameter	Packaging	RoHS
GT10-2022PCF	760-0006-8	Brass	Tin plating	20 to 22 AWG	φ 1.1 to 1.3	10,000 pcs/reel	YES

● Housing

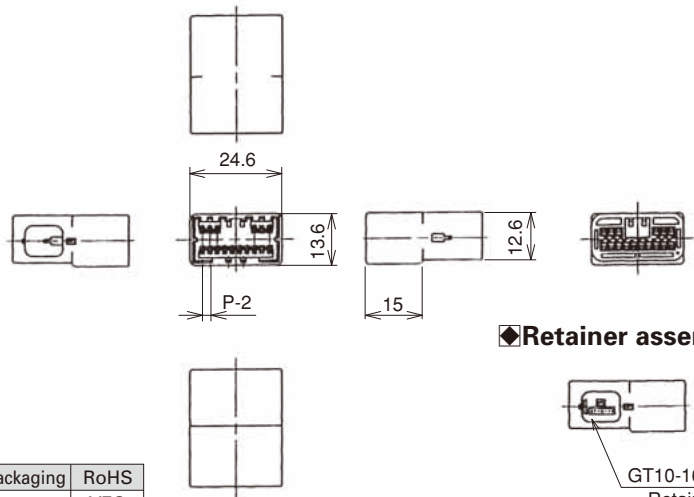
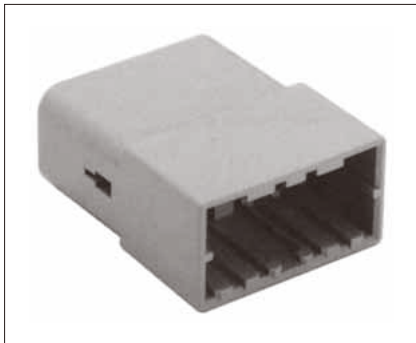

◆ Retainer assembled.

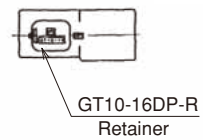

Part No.	HRS No.	Color	Material	Packaging	RoHS
GT10-16DP-HU	760-0004-2	Light Gray	PBT	1	YES

Note: This product has a retainer provisionally attached to the housing.

At time of use, install the retainer all the way to the specified position after the terminal has been inserted.

● Retainer (Only for GT10-16DP-HU)

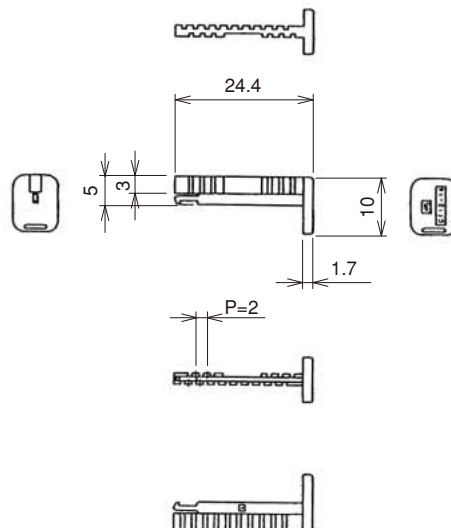

Part No.	HRS No.	Color	Material	Packaging	RoHS
GT10-16DP-R	760-0005-5	Dark Gray	PBT	1	YES

● Board Type

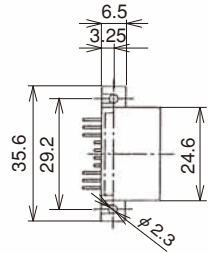
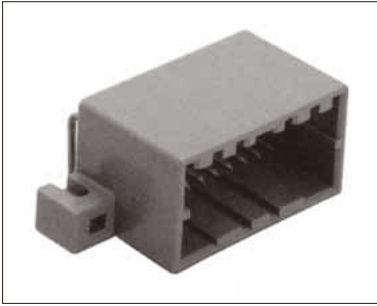

◆ Recommended PCB pattern

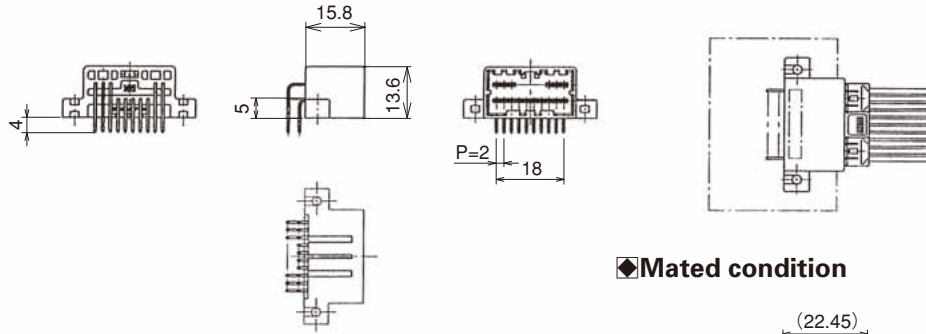
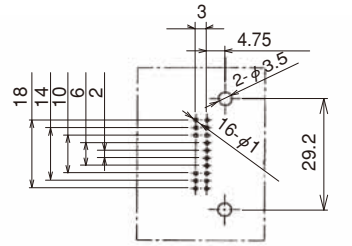

◆ Mated condition

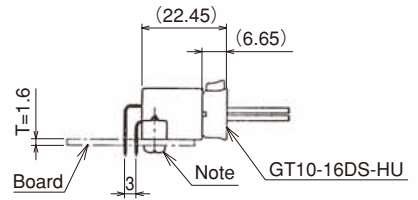

Part No.	HRS No.	Material/Plating or Color	Packaging	RoHS
GT10-16DP-DS(70)	760-0001-4 70	Housing : PBT / Light Gray Terminal : Brass / Tin plating	1	YES

Note : Use class 4 JIS B 1115 and 1122 mounting screws and diameter 3, length 6 (for a board thickness of 1.6mm).

◆ Crimping tools

User manuals are available. Please contact your Hirose Electric account representative.

● Automatic Crimping Machine

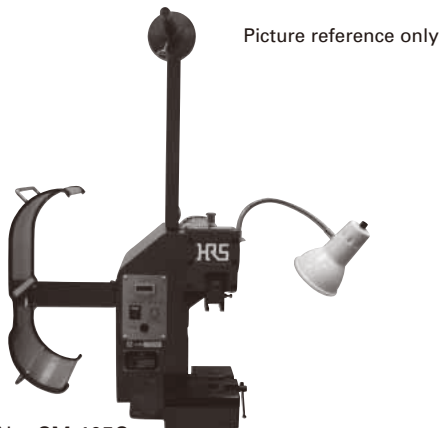

Part No. CM-105C

Specifications

Item	Specification	Remarks
Press capacity	1.5tons	—
Stroke Length	30mm	—
Number of strokes	200spm (50Hz)	240spm (60Hz)
Weight	75kg	—
Motor	0.2kw	AC100V
Crimping speed	2,000 to 4,000 pcs/hour	—

● Harness tool

Terminal Part No.	Terminal HRS No.	Tool Part No.	Tool HRS No.
GT10-2022SCF	760-0003-0	AP105-GT10-2022S	901-5016-8
GT10-2022PCF	760-0006-8	AP105-GT10-2022P	901-5049-7
GT10-2428SCF	765-0009-6	AP105-GT10-2428S	901-5063-4