



CY8CKIT-019

PSoC[®] Shield Adapter Kit Guide

Doc. #: 001-90332 Rev. **

Cypress Semiconductor
198 Champion Court
San Jose, CA 95134-1709
Phone (USA): +1.800.858.1810
Phone (Intl): +1.408.943.2600
<http://www.cypress.com>

Copyrights

© Cypress Semiconductor Corporation, 2013. The information contained herein is subject to change without notice. Cypress Semiconductor Corporation assumes no responsibility for the use of any circuitry other than circuitry embodied in a Cypress product. Nor does it convey or imply any license under patent or other rights. Cypress products are not warranted nor intended to be used for medical, life support, life saving, critical control or safety applications, unless pursuant to an express written agreement with Cypress. Furthermore, Cypress does not authorize its products for use as critical components in life-support systems where a malfunction or failure may reasonably be expected to result in significant injury to the user. The inclusion of Cypress products in life-support systems application implies that the manufacturer assumes all risk of such use and in doing so indemnifies Cypress against all charges.

Any Source Code (software and/or firmware) is owned by Cypress Semiconductor Corporation (Cypress) and is protected by and subject to worldwide patent protection (United States and foreign), United States copyright laws and international treaty provisions. Cypress hereby grants to licensee a personal, non-exclusive, non-transferable license to copy, use, modify, create derivative works of, and compile the Cypress Source Code and derivative works for the sole purpose of creating custom software and or firmware in support of licensee product to be used only in conjunction with a Cypress integrated circuit as specified in the applicable agreement. Any reproduction, modification, translation, compilation, or representation of this Source Code except as specified above is prohibited without the express written permission of Cypress.

Disclaimer: CYPRESS MAKES NO WARRANTY OF ANY KIND, EXPRESS OR IMPLIED, WITH REGARD TO THIS MATERIAL, INCLUDING, BUT NOT LIMITED TO, THE IMPLIED WARRANTIES OF MERCHANTABILITY AND FITNESS FOR A PARTICULAR PURPOSE. Cypress reserves the right to make changes without further notice to the materials described herein. Cypress does not assume any liability arising out of the application or use of any product or circuit described herein. Cypress does not authorize its products for use as critical components in life-support systems where a malfunction or failure may reasonably be expected to result in significant injury to the user. The inclusion of Cypress' product in a life-support systems application implies that the manufacturer assumes all risk of such use and in doing so indemnifies Cypress against all charges.

Use may be limited by and subject to the applicable Cypress software license agreement.

PSoC and CapSense are registered trademarks and PSoC Creator is a trademark of Cypress Semiconductor Corp. All other trademarks or registered trademarks referenced herein are property of the respective corporations.

Flash Code Protection

Cypress products meet the specifications contained in their particular Cypress PSoC Data Sheets. Cypress believes that its family of PSoC products is one of the most secure families of its kind on the market today, regardless of how they are used. There may be methods, unknown to Cypress, that can breach the code protection features. Any of these methods, to our knowledge, would be dishonest and possibly illegal. Neither Cypress nor any other semiconductor manufacturer can guarantee the security of their code. Code protection does not mean that we are guaranteeing the product as 'unbreakable'.

Cypress is willing to work with the customer who is concerned about the integrity of their code. Code protection is constantly evolving. We at Cypress are committed to continuously improving the code protection features of our products.

Contents



| | |
|--|-----------|
| 1. Introduction | 4 |
| 1.1 Kit Contents | 4 |
| 1.2 Getting Started..... | 5 |
| 1.3 Additional Learning Resources..... | 5 |
| 1.4 Technical Support..... | 5 |
| 1.5 Document Conventions | 5 |
| 2. Software Installation | 6 |
| 2.1 Kit Software | 6 |
| 2.2 Install Hardware..... | 8 |
| 2.3 Uninstall Software..... | 8 |
| 2.4 Open a Code Example Project in PSoC Creator | 9 |
| 3. Kit Operation | 11 |
| 3.1 Connecting the Shield Adapter Kit to the PSoC 4 Pioneer Kit..... | 12 |
| 3.2 Loading the First PSoC Shield Adapter Project..... | 12 |
| 4. Hardware | 15 |
| 4.1 Board Details | 15 |
| 4.2 Theory of Operation..... | 15 |
| 4.3 Functional Description | 16 |
| 4.3.1 PSoC 4..... | 16 |
| 4.3.2 Power Supply System..... | 16 |
| 4.3.3 Arduino Compatible Headers (J1, J2, J3, J4, and J12)..... | 17 |
| 4.3.4 PSoC 5LP Header (J8) | 18 |
| 4.3.5 Expansion Board Kit Adapter Header (J10) | 18 |
| 4.3.6 Prototyping Connector (J9) | 20 |
| 4.3.7 Push Buttons..... | 20 |
| 4.3.8 User LEDs..... | 21 |
| 4.3.9 10K-Ohm Rotary Potentiometer..... | 21 |
| 4.3.10 Thermistor | 22 |
| A. Appendix | 23 |
| A.1 PSoC Shield Adapter Kit Schematics | 23 |
| A.2 Bill of Materials | 27 |

1. Introduction



Thank you for your interest in the CY8CKIT-019 PSoC[®] Shield Adapter Kit. This kit is designed to be used with the Cypress CY8CKIT-042 PSoC 4 Pioneer Kit. The kit supports the pin layout and header profile of the PSoC 4 Pioneer Kit.

This kit is designed to provide simple user interfaces and integration with the Cypress expansion board kits (EBKs), and it incorporates onboard functionality to evaluate and develop using the PSoC 4 Pioneer Kit. The onboard functionality includes breakout headers, LEDs, a potentiometer, push buttons, and a thermistor. The PSoC Shield Adapter is Arduino[™] compatible and supports a stackable shield design.

1.1 Kit Contents

The PSoC Shield Adapter Kit contains the following:

- PSoC Shield Adapter board (Figure 1-1)
- Quick Start Guide
- 6 jumper wires

Inspect the content of your kit. If any part is missing, then contact your nearest Cypress sales office. For further information, go to www.cypress.com/go/support.

Figure 1-1. PSoC Shield Adapter Board

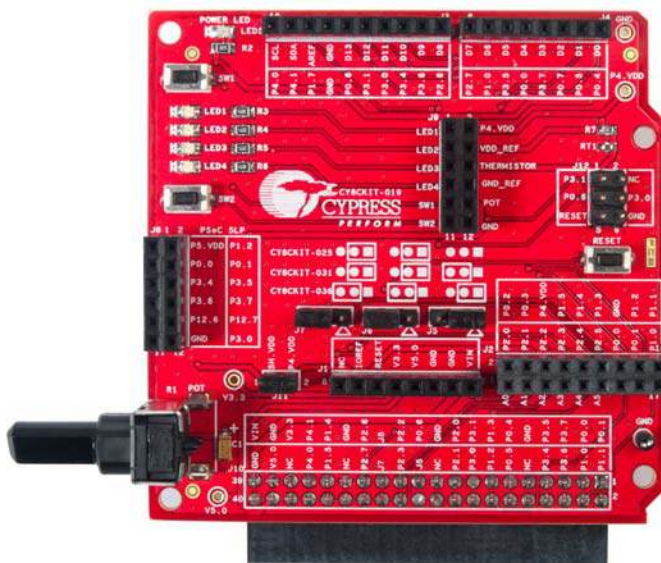

1.2 Getting Started

This user guide helps you get acquainted with the PSoC Shield Adapter Kit. The [Software Installation chapter on page 6](#) describes the installation of the PSoC 4 Pioneer Kit software. The [Kit Operation chapter on page 11](#) explains how to program the PSoC 4 Pioneer Kit and use the PSoC Shield Adapter. The [Hardware chapter on page 15](#) details the hardware operation of the kit. Finally, the [Appendix on page 23](#) provides the kit schematics and the bill of materials (BOM).

1.3 Additional Learning Resources

For more information on PSoC, see the following links:

- www.cypress.com/psoc
- www.cypress.com/psoc4
- www.cypress.com/psoccreator
- www.cypress.com/go/CY8CKIT-042
- www.cypress.com/go/CY8CKIT-025
- www.cypress.com/go/CY8CKIT-031
- www.cypress.com/go/CY8CKIT-036

1.4 Technical Support

For assistance, go to our support web page: <http://www.cypress.com/go/support> or contact our customer support at +1(800) 541-4736 Ext. 8 (in the U.S.), or +1 (408) 943-2600 Ext. 8 (International).

1.5 Document Conventions

Table 1-1. Document Conventions for Guides

| Convention | Usage |
|--------------------|---|
| Courier New | Displays file locations, user entered text, and source code: <code>C:\...cd\icc\</code> |
| <i>Italics</i> | Displays file names and reference documentation: Read about the <i>sourcefile.hex</i> file in the <i>PSoC Creator User Guide</i> . |
| [Bracketed, Bold] | Displays keyboard commands in procedures: [Enter] or [Ctrl] [C] |
| File > Open | Represents menu paths: File > Open > New Project |
| Bold | Displays commands, menu paths, and icon names in procedures: Click the File icon and then click Open . |
| Times New Roman | Displays an equation: $2 + 2 = 4$ |
| Text in gray boxes | Describes Cautions or unique functionality of the product. |

2. Software Installation



2.1 Kit Software

The PSoC Shield Adapter Kit does not require an installer, but it is recommended that you install the [PSoC 4 Pioneer Kit Installer](#).

The PSoC 4 Pioneer Kit Installer includes the PSoC Creator™ software and all of the kit related content. Navigate to the PSoC 4 Pioneer Kit web page and download the installer. You can then run the downloaded installer. To install the PSoC 4 Pioneer Kit, follow these steps:

1. Run the installer and select the folder to install the CY8CKIT-042 PSoC 4 Pioneer Kit related files. Choose the directory and click **Next**, as shown in [Figure 2-1](#).

Figure 2-1. Initiating Pioneer Kit Installation

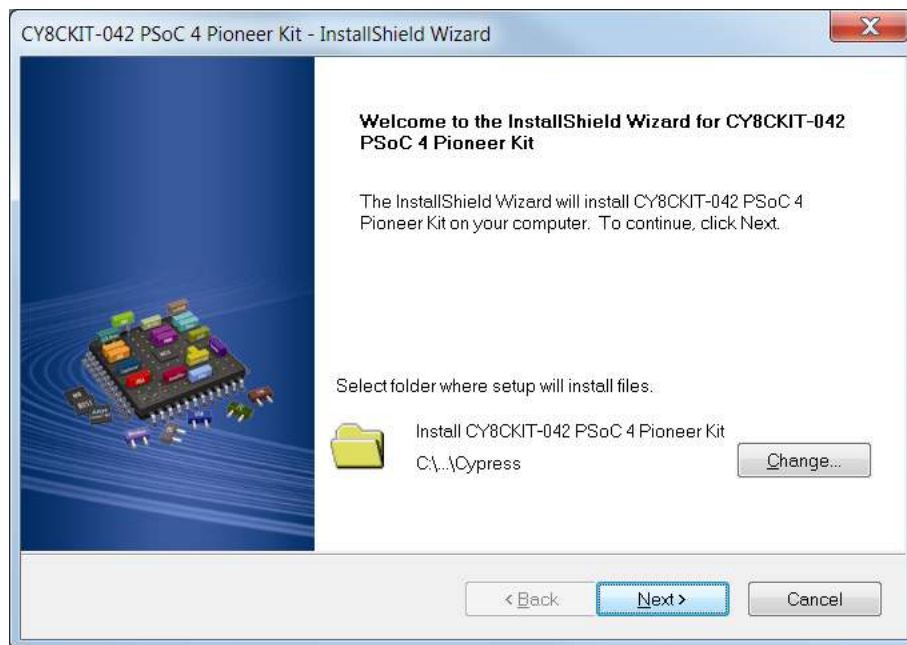

2. Select the Installation type and click **Next**, as shown in [Figure 2-2](#).

Figure 2-2. Selecting Installation Type

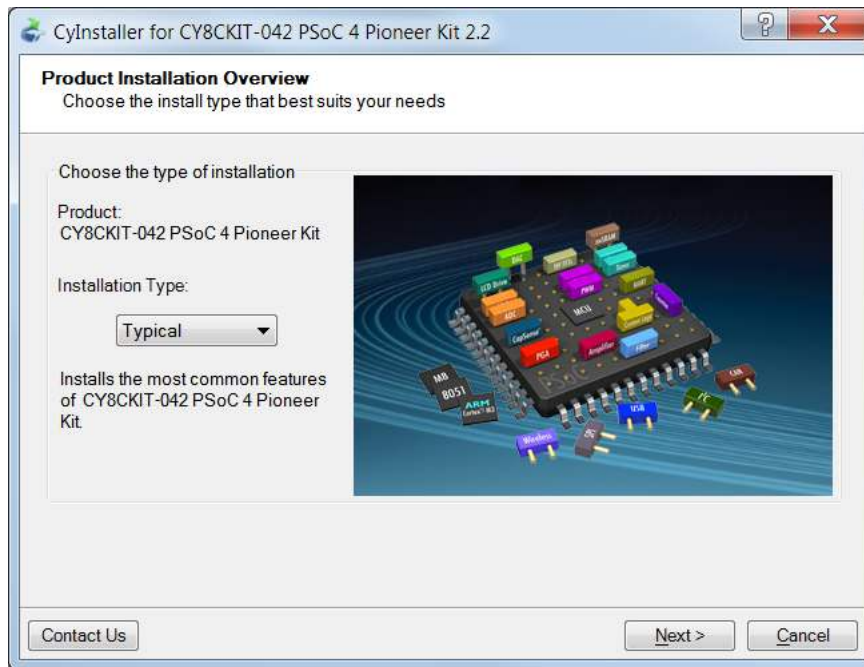

3. After the installation is complete, the kit contents are available at the following locations:

```
<Install_Directory>\CY8CKIT-042 PSoC 4 Pioneer Kit\<version>
<Install_Directory>\PSoC Creator\<version>
```

The default install directory is C:\Program Files\Cypress\

You can download the code examples for this kit from www.cypress.com/go/CY8CKIT-019.

The PSoC Shield Adapter also supports Expansion Board Kits (EBK). The following is a list of the kits that the PSoC Shield Adapter supports. Navigate to the kit pages for additional installers, information, and content. Each kit page provides links to download the installers, application notes, and example projects that use the CY8CKIT-019 PSoC Shield Adapter Kit.

CY8CKIT-025 - PSoC Precision Analog Temperature Sensor Expansion Board Kit

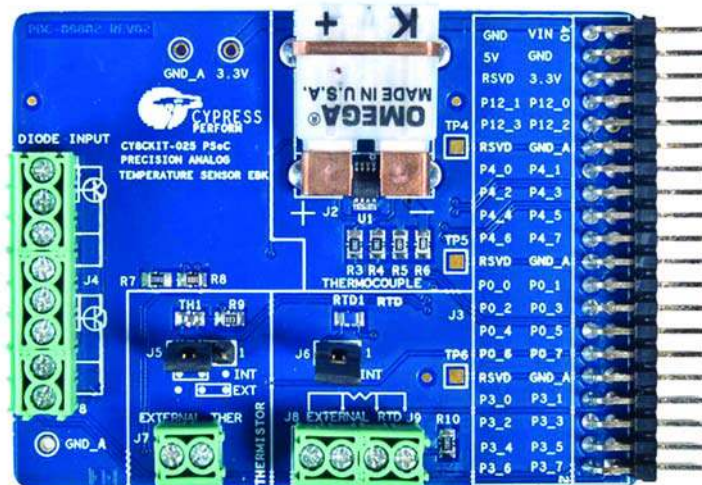

CY8CKIT-031 - PSoC CapSense Expansion Board Kit

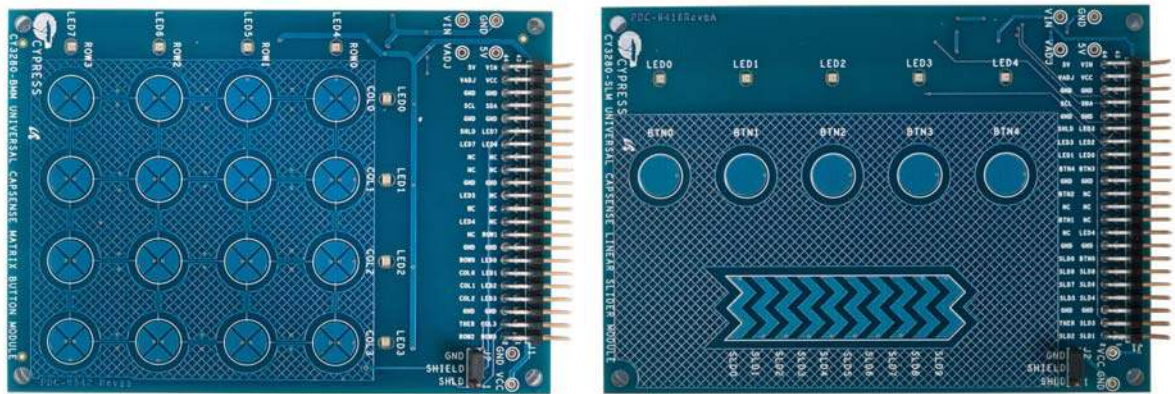

CY8CKIT-036 - PSoC Thermal Management Expansion Board Kit



2.2 Install Hardware

There is no additional hardware installation required for this kit.

2.3 Uninstall Software

The software and kit installers can be uninstalled using one of the following methods:

- Go to **Start > All Programs > Cypress > Cypress Update Manager > Cypress Update Manager**; click the **Uninstall** button.
- Go to **Start > Control Panel > Programs and Features**; click the **Uninstall/Change** button.

2.4 Open a Code Example Project in PSoC Creator

1. Launch PSoC Creator software (Figure 2-3) from the Start menu. The path is **Start > All Programs > Cypress > PSoC Creator x.x > PSoC Creator x.x**, where "x.x" is the PSoC Creator version.

Figure 2-3. PSoC Creator

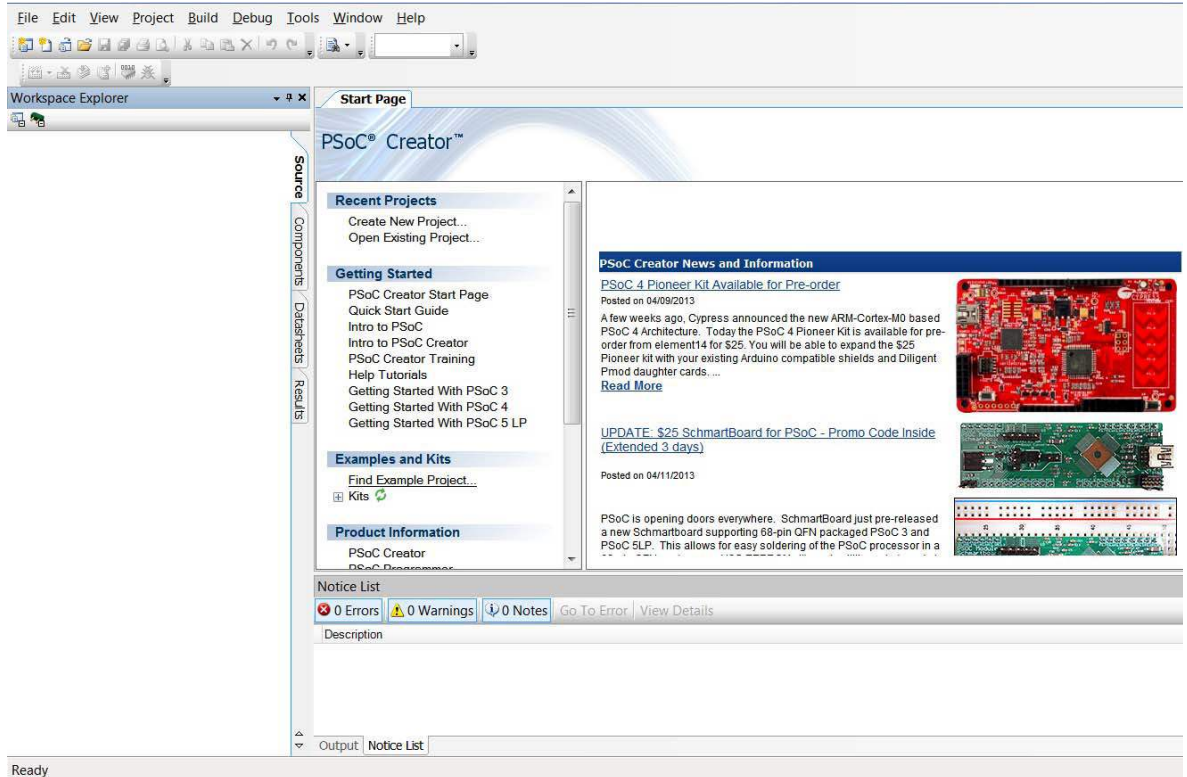

2. Open the example projects by selecting **File > Open > Project/Workspace** and then navigating to the example project that was downloaded from the kit web page.

Figure 2-4. Opening Example Projects

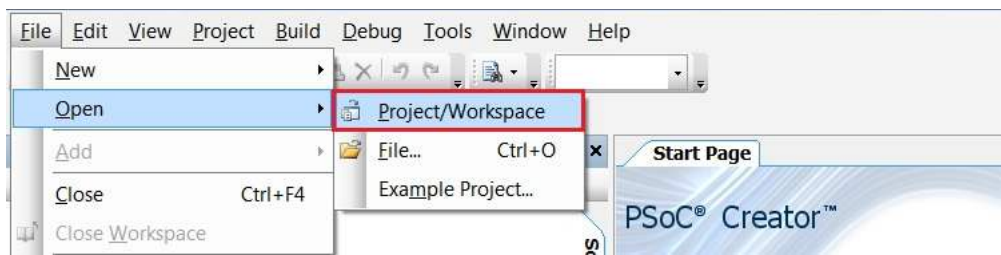

The example project opens and displays the project files in the Workspace Explorer, as shown in Figure 2-5. Subsequent sections of this user guide show how to program and verify the output of the example project supported by this kit.

Figure 2-5. Project Files in Workspace Explorer

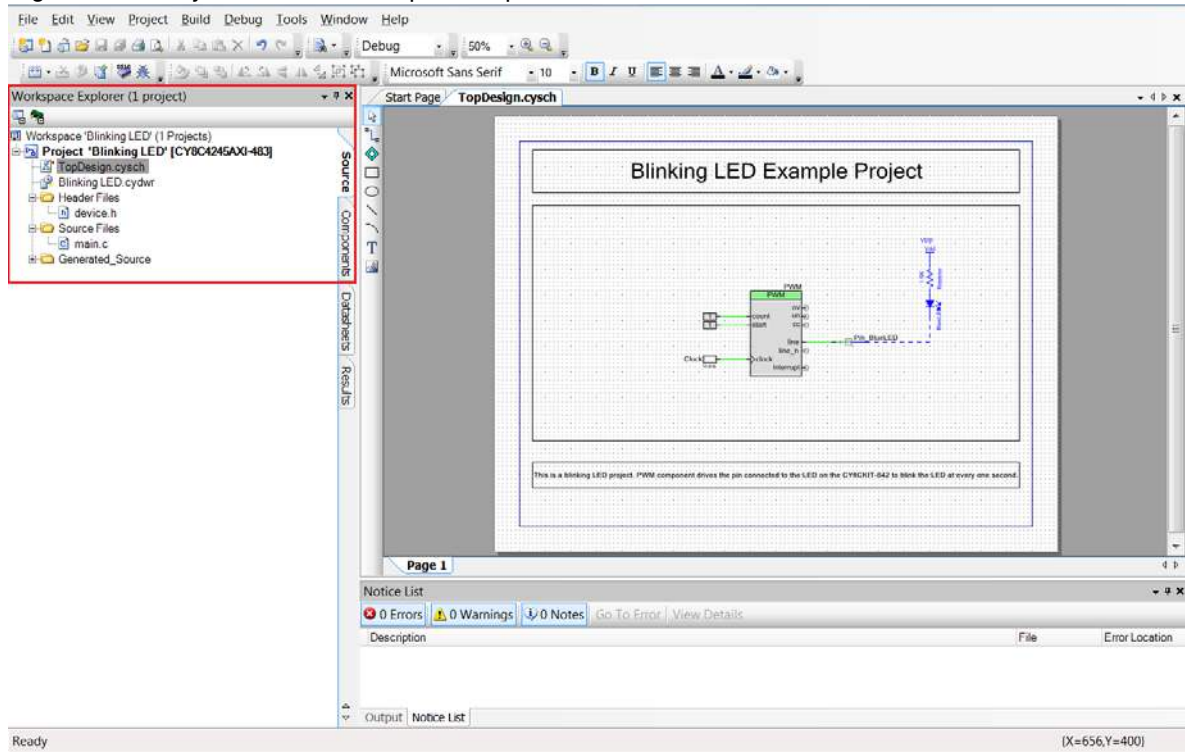

3. Kit Operation



The PSoC Shield Adapter Kit enables you to develop applications using the PSoC 4 Pioneer Kit and Cypress EBKs. Figure 3-1 shows an image of the kit with references to the onboard components.

Figure 3-1. PSoC Shield Adapter Kit Components

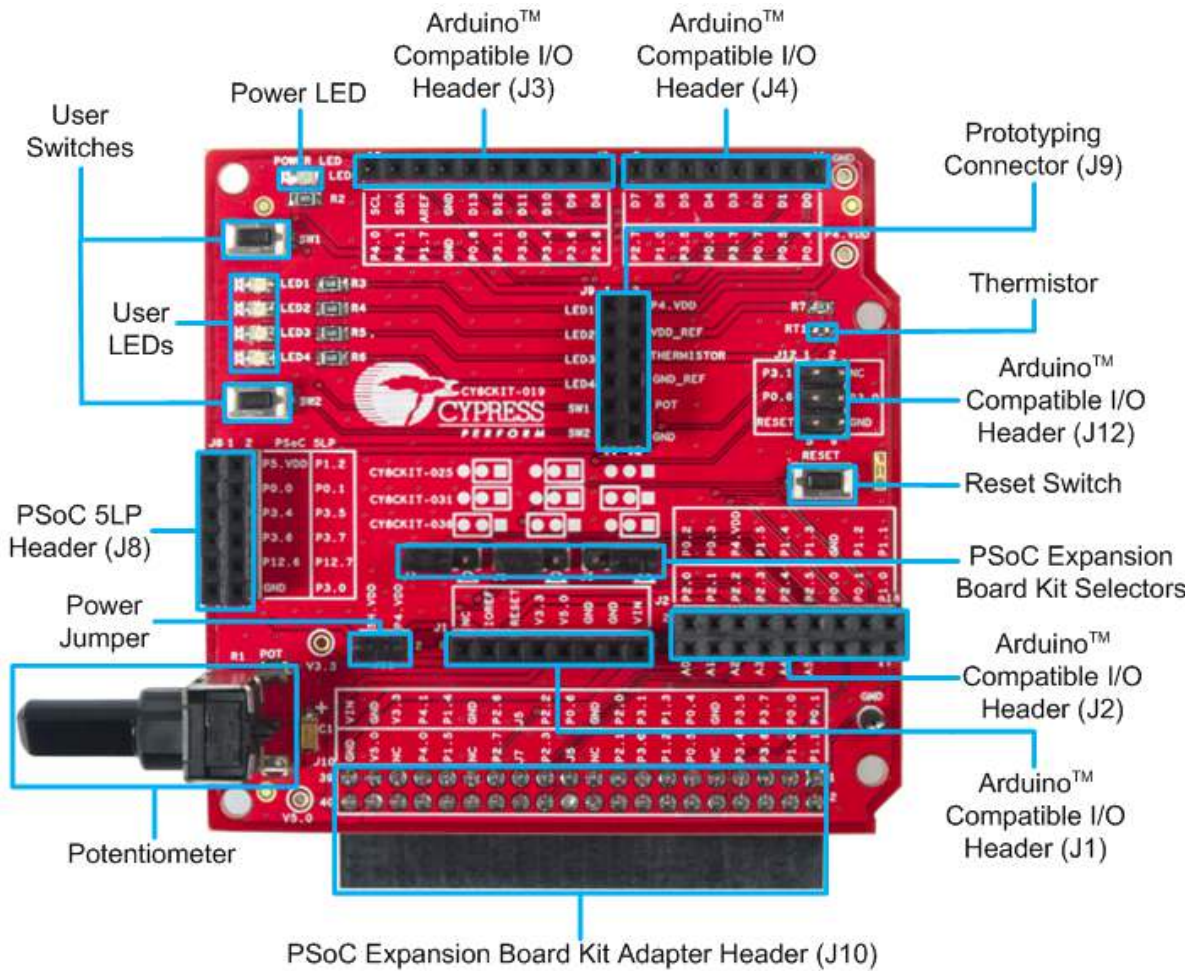

3.1 Connecting the Shield Adapter Kit to the PSoC 4 Pioneer Kit

To use the PSoC Shield Adapter Kit, you need to connect the shield to the PSoC 4 Pioneer Kit. The PSoC Shield Adapter Kit is designed to be connected to the entire header network on the PSoC 4 Pioneer Kit. You can key the headers and insert the shield into the PSoC 4 Pioneer Kit.

Figure 3-2. CY8CKIT-019 Shield Adapter Kit Connected to CY8CKIT-042 PSoC 4 Pioneer Kit

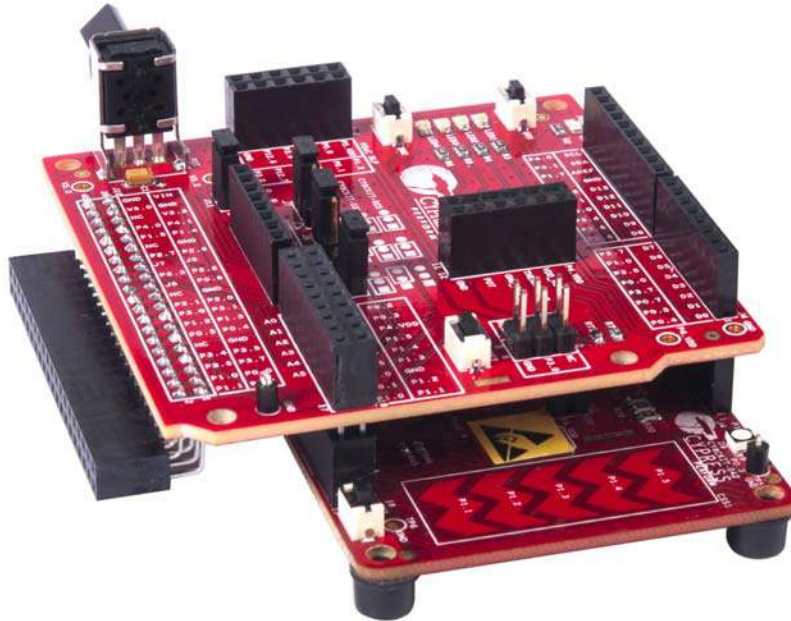

After the PSoC Shield Adapter is connected to the PSoC 4 Pioneer Kit, you can develop custom applications, plug in new Arduino shields, or connect one of the Cypress EBKs to the shield's EBK adapter.

3.2 Loading the First PSoC Shield Adapter Project

Available on the PSoC Shield Adapter Kit web page is an example project for the PSoC 4 Pioneer Kit. This example project can be programmed onto the PSoC 4 device to blink an LED on the PSoC Shield Adapter board. To verify this project, do the following:

1. Download and install the PSoC 4 Pioneer Kit Installer, as described in the [Software Installation on page 6](#).
2. Download the example project from the kit web page at www.cypress.com/go/CY8CKIT-019.
3. Unzip the example project to the desired location.
4. Connect the USB cable from the PC to the CY8CKIT-042 PSoC 4 Pioneer Kit.
5. Connect a jumper wire from the PSoC Shield Adapter prototyping header (LED1) on J9 to P0.4 (on J4), as shown in [Figure 3-3](#).

Figure 3-3. Connecting a Jumper Wire

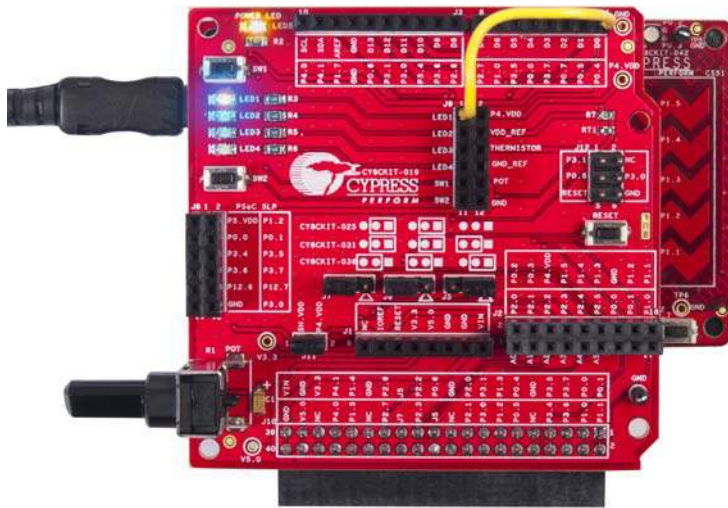

6. Launch PSoC Programmer (Figure 3-4) from **Start > All Programs > Cypress > PSoC Programmer x.x.x > PSoC Programmer x.x.x**, where x.x.x is the version. Using the **File Load** button on PSoC Programmer, navigate to the example project you have unzipped and select the *Blinking LED.hex* file. This file is located under the Hex File sub-directory.
7. If the Status bar on the lower right corner of the PSoC Programmer window does not say "Connected", click on the KitProg programmer in the Port Selection window to connect.

Figure 3-4. PSoC Programmer

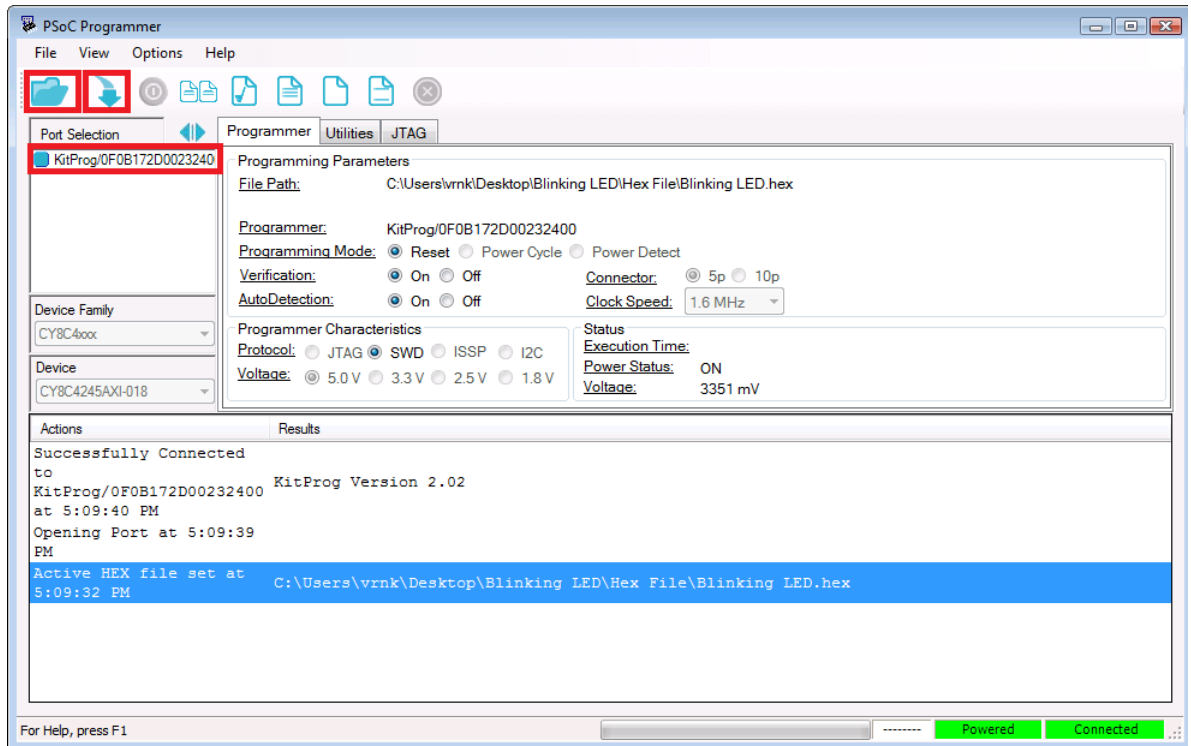

8. Click the **Program** button on PSoC Programmer. After programming, you will see that LED1 blinks, as shown in [Figure 3-5](#).

Figure 3-5. LED1 Blinking



For more examples and solutions, refer to the EBK web pages and their associated solution documents:

- www.cypress.com/go/CY8CKIT-025
- www.cypress.com/go/CY8CKIT-031
- www.cypress.com/go/CY8CKIT-036

4. Hardware



4.1 Board Details

As shown in [Figure 3-1](#), the PSoC Shield Adapter Kit consists of the following sections:

- Power supply system
- Arduino headers
- PSoC 5LP header
- Expansion board kit adapter headers
- Expansion board kit selector jumpers
- LEDs
- Thermistor
- Push buttons
- Potentiometer

4.2 Theory of Operation

This section provides a block-level description of the PSoC Shield Adapter Kit, as illustrated in [Figure 4-1](#).

Figure 4-1. PSoC Shield Adapter Kit Block-Level Diagram

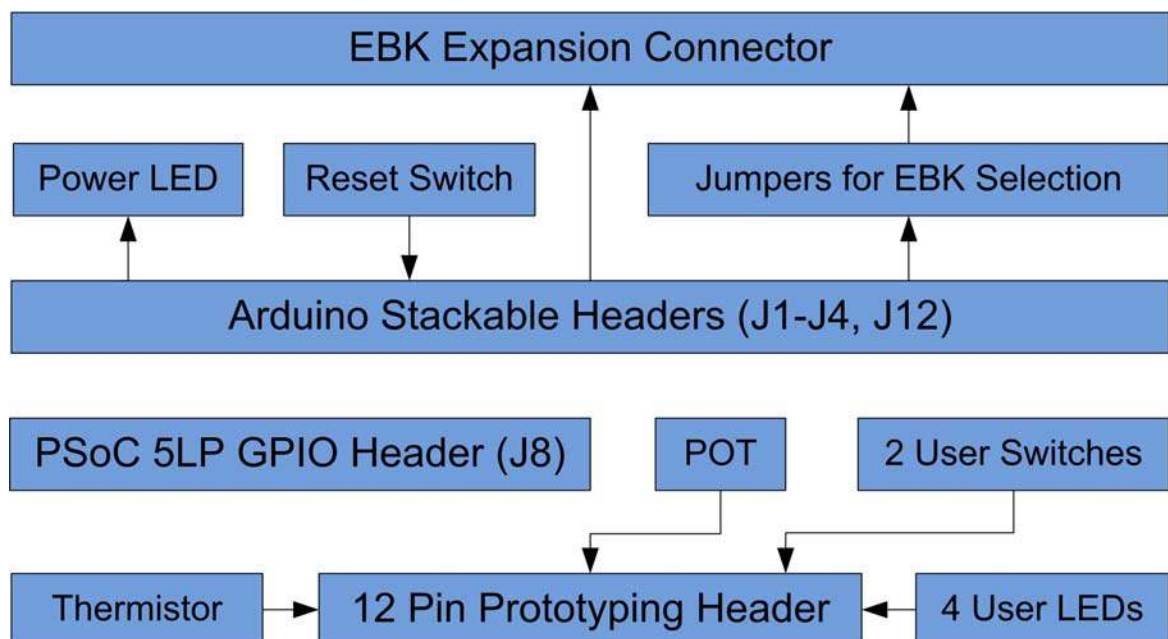

The PSoC Shield Adapter board primarily provides header support for the PSoC 4 Pioneer Kits and their connection to Cypress Expansion Board Kits (EBKs). The PSoC Shield Adapter Kit supports connecting Arduino compatible shields and Cypress EBK development kits.

The kit supports onboard functionality for development and evaluation of PSoC 4-based designs. The PSoC Shield Adapter board incorporates LEDs, push buttons, a potentiometer, and a thermistor. These features can be connected to the prototyping connector on the Shield Adapter Kit.

The PSoC Shield Adapter Kit supports four user LEDs and a power LED. The user LEDs can be connected to the prototyping connector. It also supports a reset push button for resetting the PSoC 4 device on the PSoC 4 Pioneer Kit.

The PSoC 5LP header is not connected to any header or component on the Shield Adapter Kit - it only connects to the PSoC 5LP, which is included on the PSoC 4 Pioneer Kit. You can connect jumper wires from the PSoC 5LP header to various headers to expand functionality and to communicate to the PSoC 5LP.

4.3 Functional Description

4.3.1 PSoC 4

The PSoC Shield Adapter Kit is used with the PSoC 4 Pioneer Kit, which supports the PSoC 4200 family of devices. These devices combine a microcontroller with programmable logic, high-performance analog-to-digital conversion, two opamps with Comparator mode, and commonly used fixed-function peripherals. For more information, refer to the [PSoC 4 web page](#) and the [PSoC 4200 Family Datasheet](#).

4.3.2 Power Supply System

The PSoC Shield Adapter board is powered using the base PSoC 4 Pioneer Kit power configurations. The power supply system (Figure 4-2) on the PSoC 4 Pioneer Kit is versatile, allowing the board to be powered from the following sources:

- 5 V from onboard USB programming header J10
- 5 V to 12 V from VIN on the Arduino header J1_01 and J11
- 3.3 V from the Arduino header J1_05
- VTARG - power from the onboard 10-pin programming headers J6 or J7 via an external programmer such as the MiniProg3

Figure 4-2. Power Supply System for the CY8CKIT-042 PSoC 4 Pioneer Kit

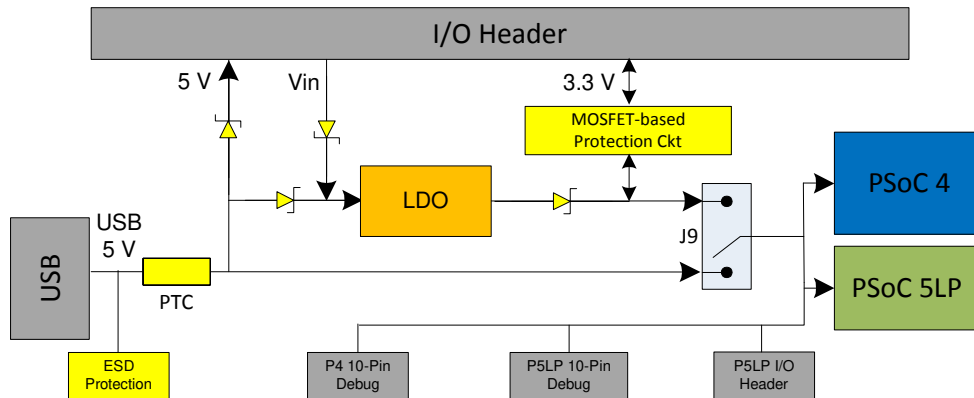

On the CY8CKIT-019 PSoC Shield Adapter Kit, a power jumper J11 is included to control the power from the PSoC 4 Pioneer Kit to the CY8CKIT-019 Shield.

Figure 4-3. Power Supply Jumper

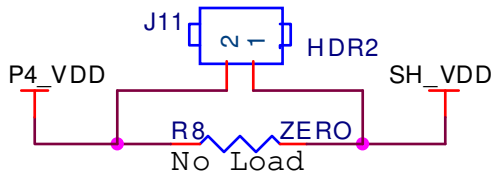

Power Jumper

4.3.3 Arduino Compatible Headers (J1, J2, J3, J4, and J12)

The kit includes four Arduino compatible headers that mirror the header pinouts and header names on the PSoC 4 Pioneer Kit. The headers are J1, J2, J3, J4, and J12. You can develop applications to interface with the PSoC 4 Pioneer Kit.

Figure 4-4. Arduino Headers for CY8CKIT-019: J1, J2, J3, J4, and J12

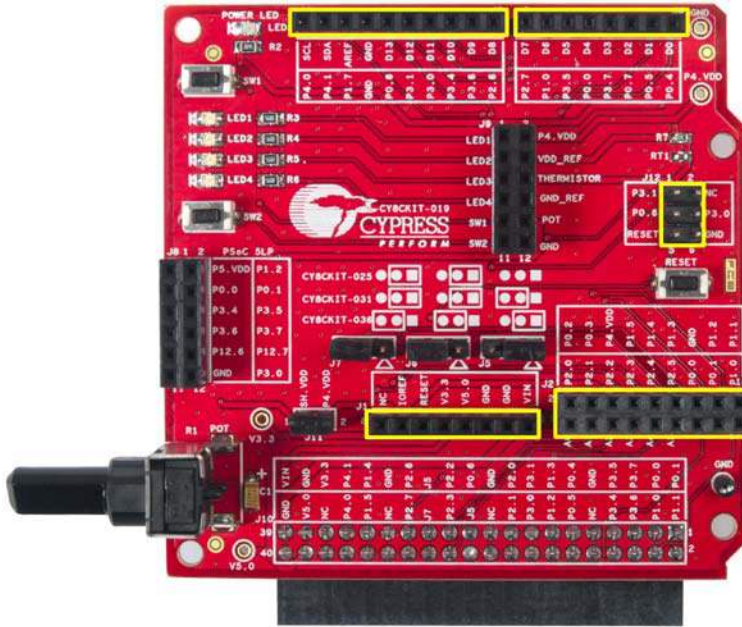

The pinout selections of the J1 to J4 and J12 Arduino headers (Figure 4-5) mirror the pinout descriptions on the PSoC 4 Pioneer Kit, allowing easy reference for existing PSoC 4 Pioneer Kit users.

Figure 4-5. Pinout Selections of J1-J4 and J12 Arduino Headers

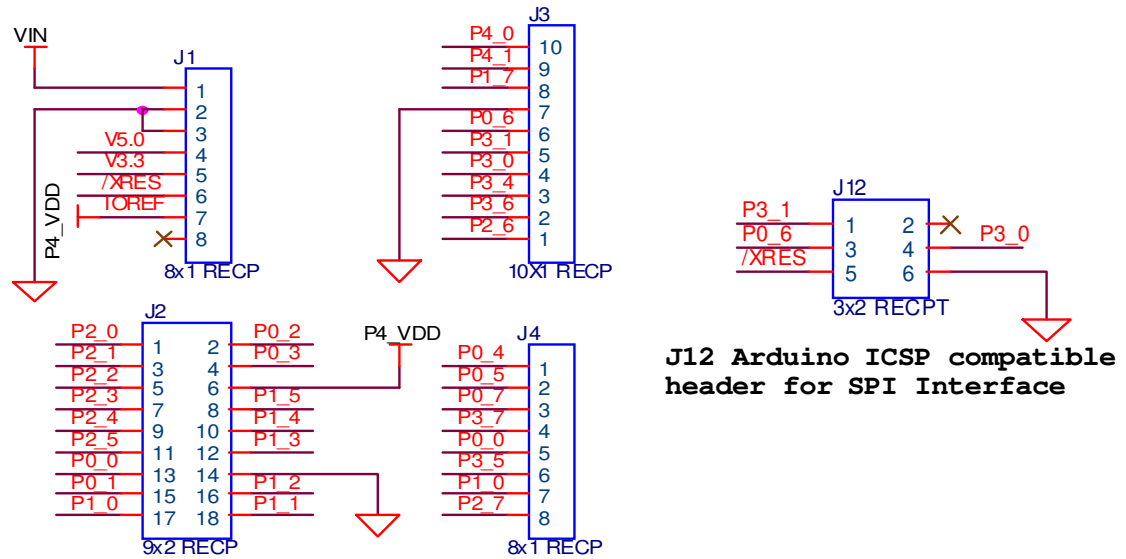

(J1–J4) Arduino Stackable Headers

J12 Arduino ICSP compatible header for SPI Interface

4.3.4 PSoC 5LP Header (J8)

The PSoC Shield Adapter Kit supports connections to the PSoC 4 Pioneer Kit PSoC 5LP header, illustrated in Figure 4-6. The shield brings the header connection from the PSoC 4 Pioneer Kit to the top layer of the Shield Adapter board. This 12-pin header supports the advanced features available using the PSoC 5LP available on the PSoC 4 Pioneer Kit.

Figure 4-6. J8 PSoC 5LP Header

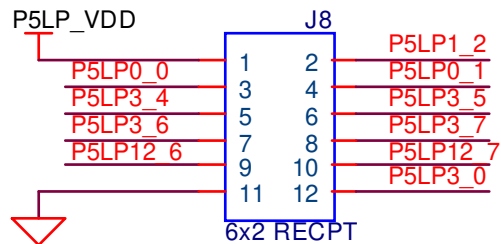
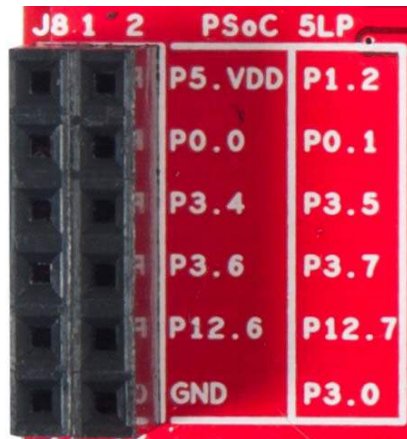

NOTE: The PSoC 5LP Pins on J8 only bring out the Pins from the Pioneer Kit and they are not connected anywhere else in this board.

PSoC 5LP GPIO Extension Header

4.3.5 Expansion Board Kit Adapter Header (J10)

The PSoC Shield Adapter Kit includes a single 2x20 pin adapter header, which is compatible with the EBKs. This header supports connecting a Cypress EBKs to the PSoC Shield Adapter board and then interfacing the EBK to the PSoC 4 Pioneer Kit.

The PSoC Shield Adapter board supports the CY8CKIT-025, CY8CKIT-031, and CY8CKIT-036 EBKs. Figure 4-7 details the pinout selections of the 40-pin header.

Figure 4-7. Pinout Selections of 40-Pin Header



4.3.5.1 PSoC Expansion Board Kit Selection Jumpers (J5, J6, J7)

The PSoC Shield Adapter Kit enables you to connect the CY8CKIT-025, CY8CKIT-031, and CY8CKIT-036 EBKs. When connecting the EBK boards to the PSoC Shield Adapter, you need to ensure the proper jumper selections. The PSoC Shield Adapter board contains three jumpers that when arranged in a specified configuration enables support for the respective EBK. Figure 4-8 provides details on the possible configurations. You can refer to the onboard silkscreen for the correct jumper configuration. By default, the PSoC Shield Adapter enables the CY8CKIT-036 EBK selection.

Figure 4-8. Expansion Board Header Jumpers and Configurations

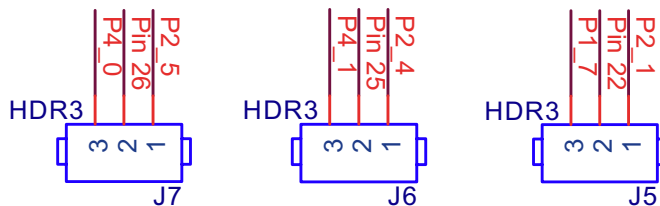
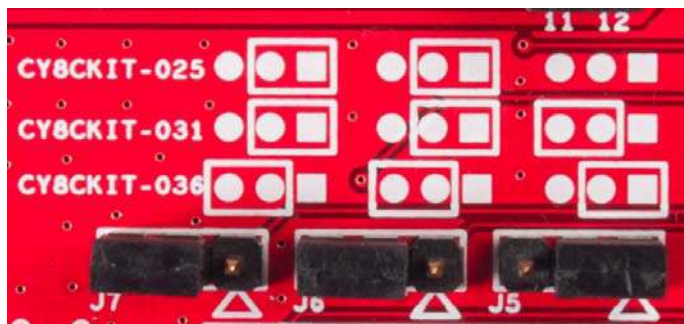

4.3.6 Prototyping Connector (J9)

The PSoC Shield Adapter board supports a number of onboard features. These features are not by default connected to any of the Arduino compatible headers or the 2x20 pin adapter header. All onboard functionality is connected through the J9 prototyping header (Figure 4-9), which is located in the center of the PSoC Shield Adapter board. You need to connect jumper wires from the J9 header to enable any of the onboard functionality such as the LEDs, switches, potentiometer, and thermistor.

Figure 4-9. J9 Prototyping Connector

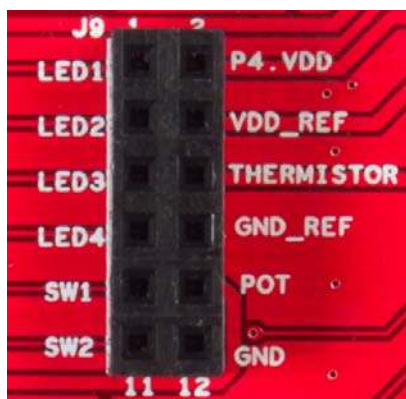

4.3.7 Push Buttons

The kit has three push buttons: two user buttons and one reset button. The two user push buttons (Figure 4-10) are available via the J9 prototyping connector. They are active pull-down buttons. To use these two buttons, you need to make a connection between J9 and the target input pin.

Figure 4-10. User Push Buttons

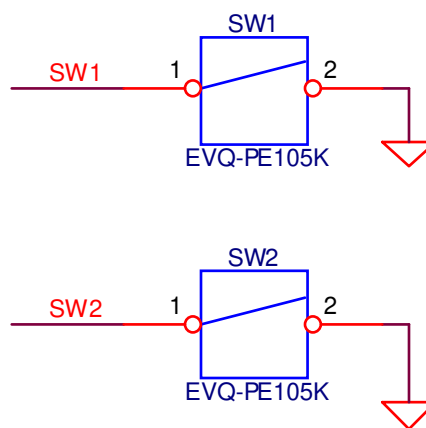

The reset push button (Figure 4-11) is connected to the XRES pin of the PSoC 4 device through the shield header and is used to reset the PSoC 4 device on the PSoC 4 Pioneer Kit.

Figure 4-11. Reset Push Button

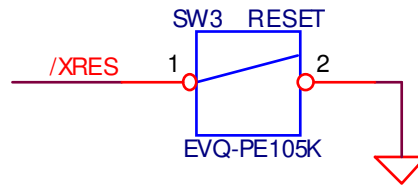
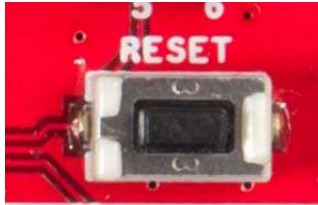

4.3.8 User LEDs

The PSoC Shield Adapter Kit supports four blue LEDs (Figure 4-12), all connected to the J9 prototyping connector. To use these LEDs, you need to make a connection between J9 and the target output pin.

Figure 4-12. Blue LEDs

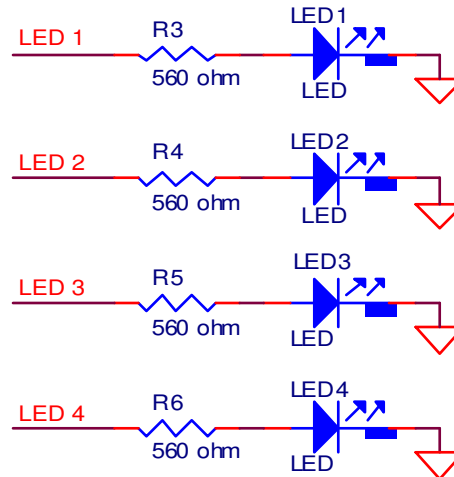

4.3.9 10K-Ohm Rotary Potentiometer

The PSoC Shield Adapter board includes a 10K-ohm rotary potentiometer (Figure 4-13) to provide manual variable voltage values. This potentiometer is labeled R1. The potentiometer connection is available on the J9 prototyping connector, so you need to wire your design to that connector to read the voltage that is output from the potentiometer. The potentiometer receives its power via J11 and will not draw any current if J11 is not connected. This is important if current measurement is needed on the PSoC 4.

Figure 4-13. Rotary Potentiometer

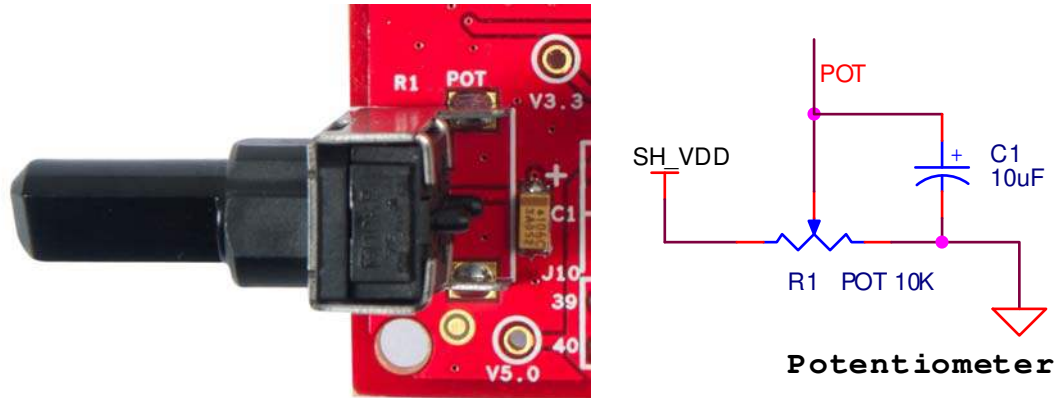

4.3.10 Thermistor

The PSoC Shield Adapter Kit supports an onboard thermistor (Figure 4-14) for measuring ambient board temperature. The thermistor used on this kit is the NCP18XH103F03RB (NTC) device, which has a 1 percent tolerance ($10K \pm 1$ percent) at 25 °C. The resistance of the thermistor changes with temperature in a nonlinear fashion. Its output is connected to the prototyping connector and can be used as an onboard temperature sensor. The thermistor receives its power via J11 and will not draw any current if J11 is not connected. This is important if current measurement is needed on the PSoC 4.

Figure 4-14. Thermistor

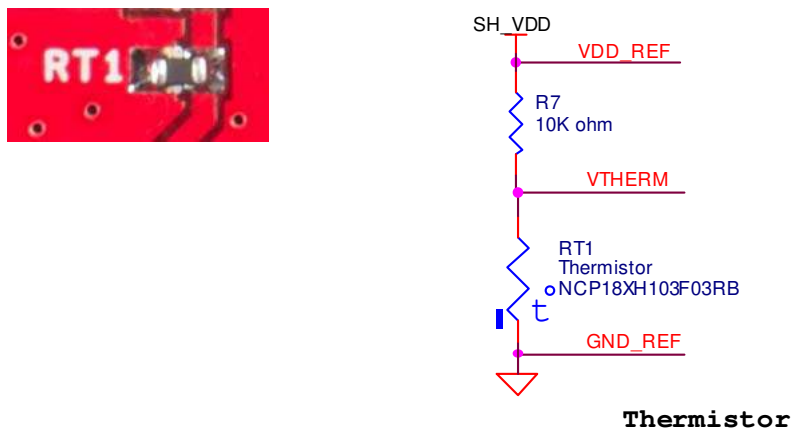

A. Appendix



A.1 PSoC Shield Adapter Kit Schematics

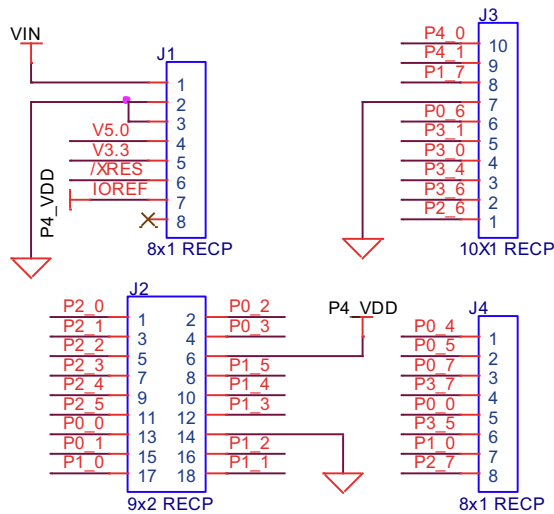

(J1-J4) Arduino Stackable Headers

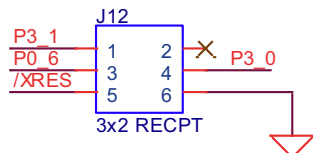

J12 Arduino ICSP compatible header for SPI Interface

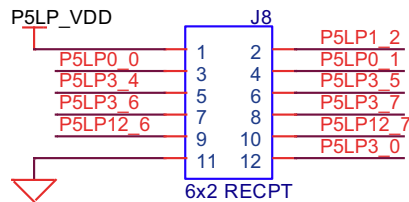

NOTE: The PSoC 5LP Pins on J8 only bring out the Pins from the Pioneer Kit and they are not connected anywhere else in this board.

PSoC 5LP GPIO Extension Header

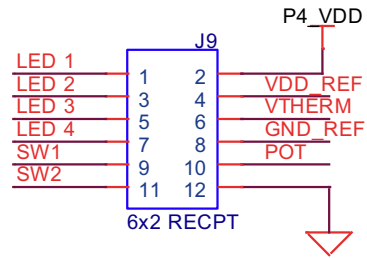

12 Pin Prototyping Header

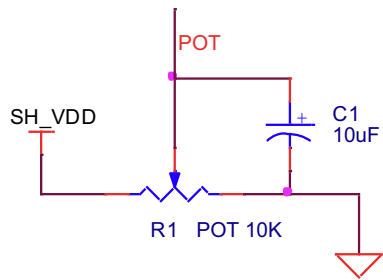

Potentiometer

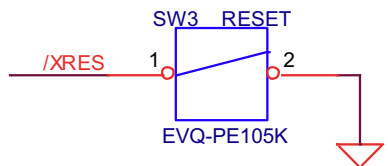
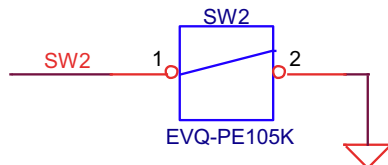
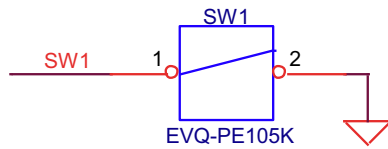

Push Buttons

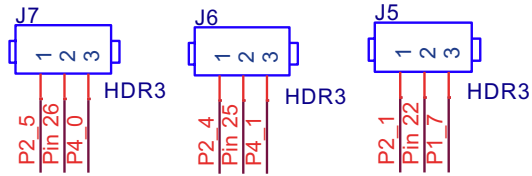

3 Pin Jumpers

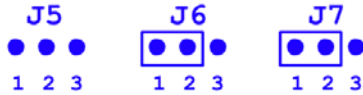

CY8CKIT-025 Jumper Settings

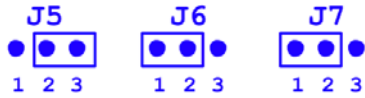

CY8CKIT-031 Jumper Settings

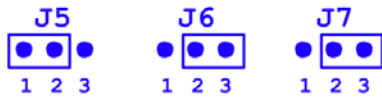

CY8CKIT-036 Jumper Settings

**Jumper Settings for
different EBKs**

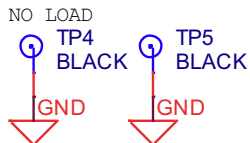
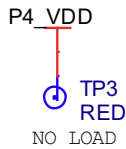
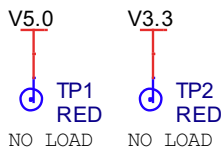

Test Points

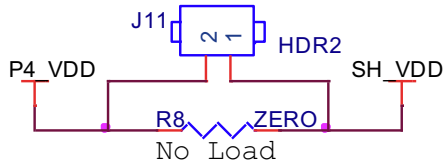

Power Jumper

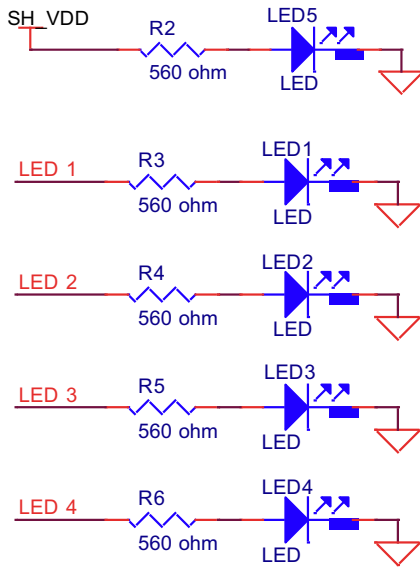

LEDs

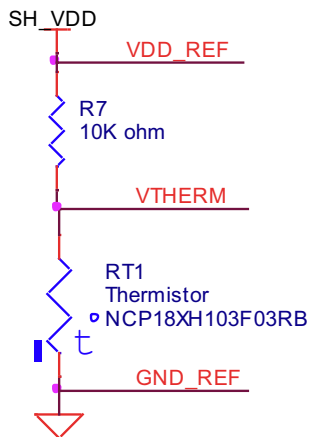

Thermistor

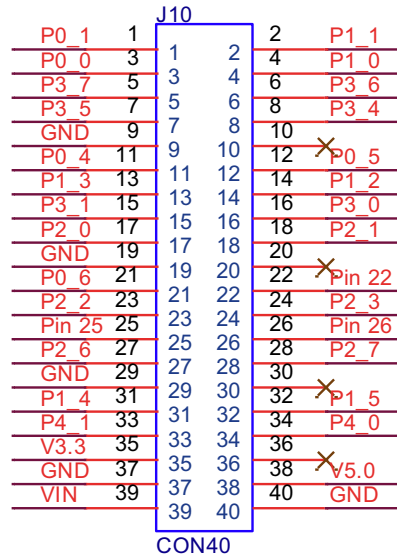

EBK Expansion Connector

A.2 Bill of Materials

| Item | Qty | Reference | Value | Description | Manufacturer | Mfr Part Number |
|------|-----|-------------|-----------------------|--|-----------------------------|----------------------------|
| 1 | 1 | N/A | N/A | PCB, 71.12mm X 72.39mm, 2 Layer, Enig Finish, High Tg, Color = RED | Cypress Semiconductor | 600-60182-01 |
| 2 | 1 | C1 | 10uF, 10V | CAP TANT 10UF 10V 20% 0805 | AVX Corporation | TAJP106M010RNJ |
| 3 | 2 | J1,J4 | 8X1 RECP (Stackable) | 8 POS Arduino Stackable Header | Samtec | SSQ-108-03-T-S |
| 4 | 1 | J2 | 9X2 RECP (Stackable) | 18 POS Dual Row Stackable Header | Samtec | SSQ-109-03-T-D |
| 5 | 1 | J3 | 10X1 RECP (Stackable) | 10 POS Arduino Stackable Header | Samtec | SSQ-110-03-T-S |
| 6 | 3 | J5,J6,J7 | 3 Pin Jumper | CONN HEADER VERT SGL 3POS GOLD | 3M | 961103-6404-AR |
| 7 | 1 | J8 | 6X2 RECP (Stackable) | 12 POS Dual Row Stackable Header | Samtec | SSQ-106-03-T-D |
| 8 | 1 | J9 | 6x2 RECP | CONN HEADER FMAL 12PS.1" DL GOLD | Sullins Connector Solutions | PPPC062LFBN-RC |
| 9 | 1 | J10 | 40X1 RECP | 40 POS Dual Row R/A Connector | Samtec | ASP?178736?01 (Customized) |
| 10 | 1 | J11 | 2 Pin Jumper | CONN HEADER VERT SGL 2POS GOLD | 3M | 961102-6404-AR |
| 11 | 1 | J12 | 3X2 RECP | CONN HEADER .100 DUAL STR 6POS | Sullins Connector Solutions | PBC03DFAN |
| 12 | 3 | SW1,SW2,SW3 | Push Button | SWITCH TACTILE SPST-NO 0.05A 12V | Panasonic | EVQ-PE105K |
| 13 | 1 | RT1 | Thermistor | THERMISTOR 10K OHM NTC 0603 SMD | Murata | NCP18XH103F03 RB |
| 14 | 1 | R1 | POT 10K | POT 10K OHM 9MM HORZ PLA SLEEVE | Panasonic | EVU-E3KFK4B14 |

| Item | Qty | Reference | Value | Description | Manufacturer | Mfr Part Number |
|--|-----|---------------------|------------------------------------|---|-----------------------|-----------------|
| 15 | 5 | R2,R3,R4,R5,R6 | 560 ohm | RES 560 OHM 1/8W 5% 0805 SMD | Panasonic | ERJ-6GEYJ561V |
| 16 | 1 | R7 | 10K Ohm | RES 10K OHM 1/10W 5% 0603 SMD | Panasonic | ERJ-3GEYJ103V |
| 17 | 4 | LED1,LED2,LED3,LED4 | Blue LEDs | LED BLUE CLEAR 0805 SMD | Lite-On Inc | LTST-C170TBKT |
| 18 | 1 | LED5 | Power LED (Amber) | LED AMBER 591NM DIFF LENS 2012 | Avago | HSMA-C170 |
| 19 | 1 | TP5 | GND Test Point (Black) | TEST POINT PC MINI .040"D Black | Keystone Electronics | 5001 |
| No Load Components | | | | | | |
| 20 | 3 | TP1,TP2,TP3 | RED | TEST POINT PC MINI .040"D RED | Keystone Electronics | 5000 |
| 21 | 1 | TP4 | BLACK | TEST POINT PC MINI .040"D Black | Keystone Electronics | 5001 |
| Special Jumper Installation Instructions | | | | | | |
| 22 | 1 | J5 | Install jumper across pins 1 and 2 | MINI JUMPER GF 6.0MM CLOSE TYPE BLACK | Kobiconn | 151-8010-E |
| 23 | 1 | J6 | Install jumper across pins 2 and 3 | MINI JUMPER GF 6.0MM CLOSE TYPE BLACK | Kobiconn | 151-8010-E |
| 24 | 1 | J7 | Install jumper across pins 2 and 3 | MINI JUMPER GF 6.0MM CLOSE TYPE BLACK | Kobiconn | 151-8010-E |
| 25 | 1 | J11 | Install jumper across pins 1 and 2 | MINI JUMPER GF 6.0MM CLOSE TYPE BLACK | Kobiconn | 151-8010-E |
| Label | | | | | | |
| 26 | 1 | N/A | N/A | LBL, PCA Label, Vendor Code, Date-code, Serial Number 121-60144-01 REV 01 (YYWWVVXXXXX) | Cypress Semiconductor | - |
| 27 | 1 | N/A | N/A | LBL, PCBA Anti-Static Warning, 10mm X 10mm | Cypress Semiconductor | - |

Revision History



CY8CKIT-019 PSoC Shield Adapter Kit Guide Revision History

| Document Title: CY8CKIT-019 PSoC® Shield Adapter Kit Guide | | | |
|---|-------------------|-------------------------|------------------------------|
| Document Number: 001-90332 | | | |
| Revision | Issue Date | Origin of Change | Description of Change |
| ** | 12/11/2013 | VRNK | New kit guide |