

NOTES:  
 1. TOTAL TRAVEL: .042±.010.  
 2. ACTUATING FORCE: 4 ±2 OZ.  
 3. TOLERANCE INCLUDES APPROX. .020 END PLAY (\*).  
 4. RATED TO MAKE AND BREAK 1/4 AMP., .115 V.A.C. RESISTIVE FOR 250,000 OPERATIONS.  
 5. MATERIALS AND FINISHES:  
 --BUSHING AND MOUNTING NUT ARE BRASS, TIN/ZINC PLATED  
 --BUTTON TOP AND BOTTOM, BASE AND INSULATING SLEEVE ARE MOLDED PHENOLIC PER MIL-M-14, TYPE CFG.  
 --SHORTING WASHER AND TERMINALS ARE FINE SILVER.  
 --SPRING IS TINNED MUSIC WIRE.

ASSEMBLY NOTES:  
 1. ASSEMBLE SWITCH AND LOCK BASE ASSEMBLY TO BUSHING.  
 2. LOCATE LABEL APPROX. AS SHOWN. LABEL TO CONTAIN E.I.A. DATE CODE.

REFERENCE NOTES:  
 GRAYHILL STANDARD 39-4.

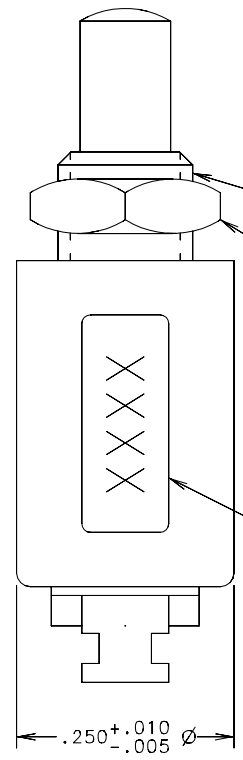
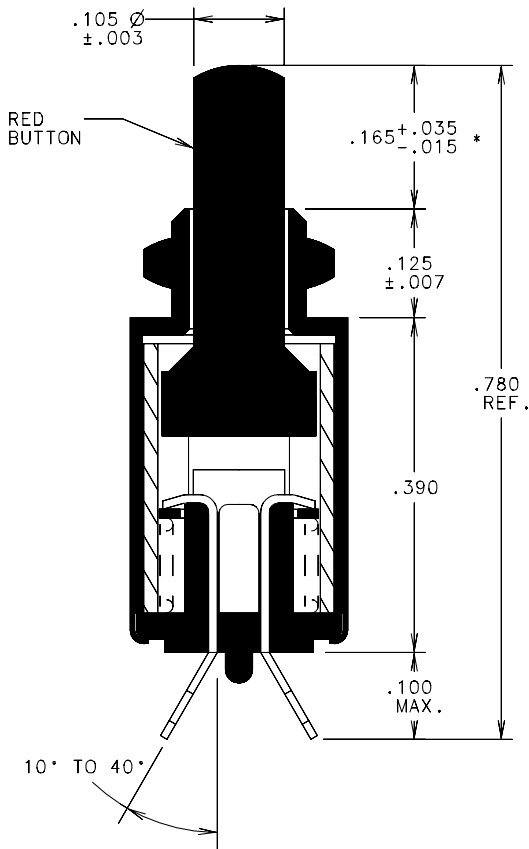

ENG210C

REVISIONS			
ISSUE	DESCRIPTION		APPD/DATE
A	ORIGINAL	ECN#346086	CWS 3-14-03 PR/CWS 3-14-03
B	MODIFIED NOTES: TIN/ZINC WAS CADMIUM ECN #371814		GAD 7-02-08 ANJ 6-30-08

ALL REVISIONS TO THIS DRAWING MUST BE MADE ON THE CAD SYSTEM

#8-40 UNS-2A TH'D FULL THREADS TO WITHIN .040 MAX. FROM SHOULDER  
 HEX. MTG. NUT 1/16 THICK 7/32 ACROSS FLATS

LABEL, SEE ASSEMBLY NOTES

CIRCUIT DIAGRAM

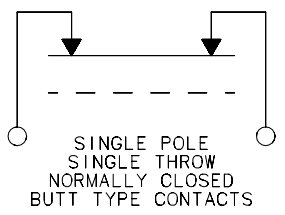

UNLESS OTHERWISE SPECIFIED TOLERANCES AND DIMENSIONS ARE IN INCHES  
 LINEAR ±.010 DIAMETERS ±.005  
 ANGULAR ± 1°  
 LIMITS APPLY BEFORE FINISHING DO NOT SCALE THIS PRINT

CRITICAL CHARACTERISTIC FLAGS PER GRAYHILL SPEC.SOP2338

- ▲ -- CRITICAL CHARACTERISTIC FLAG
- -- Cpk REQUIRED
- ☒ -- S.P.C. FLAG (CONTROL CHART REQ'D ON FEATURE SPECIFIED)

APPROVED	DATE
CWS	3-14-03
CHECKED	DATE
PR	3-14-03
DRAWN	DATE
CWS	3-14-03
FINISH	NOTED
MATERIAL	NOTED

**Grayhill** GRAYHILL, INC.  
 561 HILLGROVE AVE. PHONE (708)  
 LA GRANGE, IL 60525 354-1040

PUSHBUTTON SWITCH

B SIZE	DWG. NO.	ISSUE
	39YY2004	B