

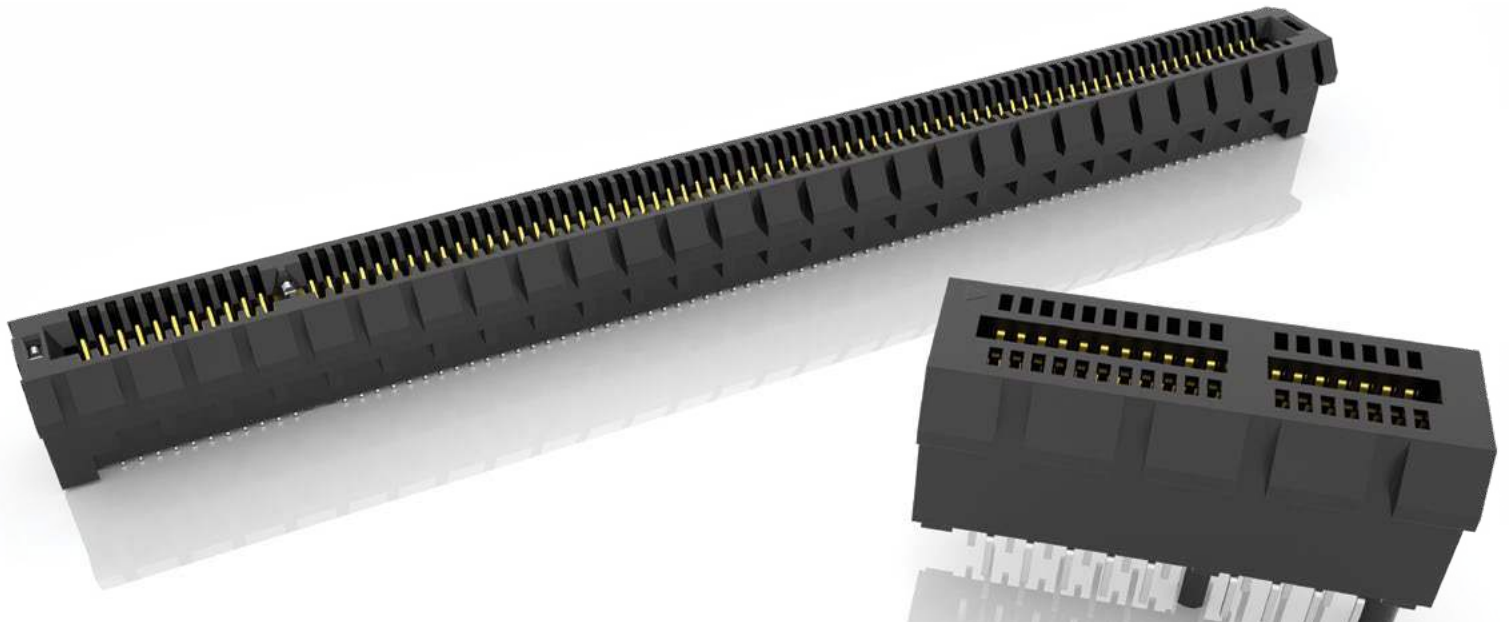

PCI EXPRESS® EDGE CARD SOCKETS

(1.00 mm) .0394" PITCH



FEATURES & BENEFITS

- 1.00 mm pitch
- Supports 1, 4, 8 and 16 PCI Express® links
- PCIe® 3.0 Solution (PCI-E)
- PCIe® 4.0 Solution with low-profile design for space savings (PCI-E-LP)
- PCIe® 4.0 with slim body design (PCI-E-G4)
- PCIe® 5.0 Solution with differential pair signaling (PCI-E-G5)
- Vertical, right-angle and edge mount
- Mates with .062" (1.60 mm) thick cards
- Alignment pin and weld tab options

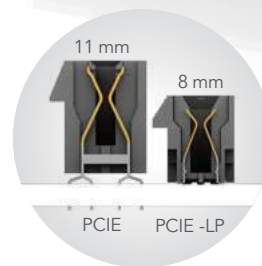

PCI-E® 3.0 & 4.0
Edge Card
connectors



PCI-E® 4.0 slim body
socket with Edge Rate®
contacts (PCI-E-G4)

KEY SPECIFICATIONS

SERIES	TOTAL PINS (LANES)	INSULATOR MATERIAL	CONTACT MATERIAL	OPERATING TEMP RANGE	CURRENT RATING	VOLTAGE RATING	PCI-E® COMPATIBILITY
PCI-E	36 (x1), 64 (x4), 98 (x8), 164 (x16)	-TH = Black Nylon -EMS2 & -TH = LCP	Phosphor Bronze	-55 °C to +125 °C	2.4 A (2 pins)	215 VAC	3.0
PCI-E-LP	36 (x1), 64 (x4), 98 (x8), 164 (x16)	LCP	Phosphor Bronze	-55 °C to +125 °C	2.1 A (2 pins)	215 VAC	4.0
PCI-E-G4	36 (x1), 64 (x4), 98 (x8), 164 (x16)	LCP	Copper Alloy	-55 °C to +125 °C	2.2 A (2 pins)	300 VAC	4.0
PCI-E-G5	36 (x1), 64 (x4), 98 (x8), 164 (x16)	LCP	Copper Alloy	-55 °C to +125 °C	3.2 A (2 pins)	235 VAC	5.0

(1.00 mm) .0394" PITCH • PCI EXPRESS® CARD SOCKETS

PCIE - **NUMBER OF POSITIONS** - **02** - **PLATING OPTION** - **D** - **TAIL OPTION**

-036, -064, -098, -164

-F
= Gold flash on contact,
Tin on tail

-EMS2
= Edge Mount

-TH
= Through-hole

-RA
= Right-angle

PCIE

Card Mates:
(1.60 mm)
.062" card
Cable Mates:
PCIEC

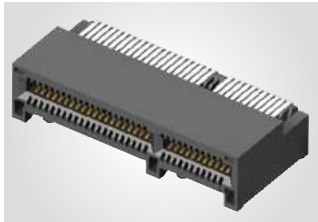

POSITIONS	A
-036 (x1)	(25.00) .984
-064 (x4)	(39.00) 1.535
-098 (x8)	(56.00) 2.205
-164 (x16)	(89.00) 3.504

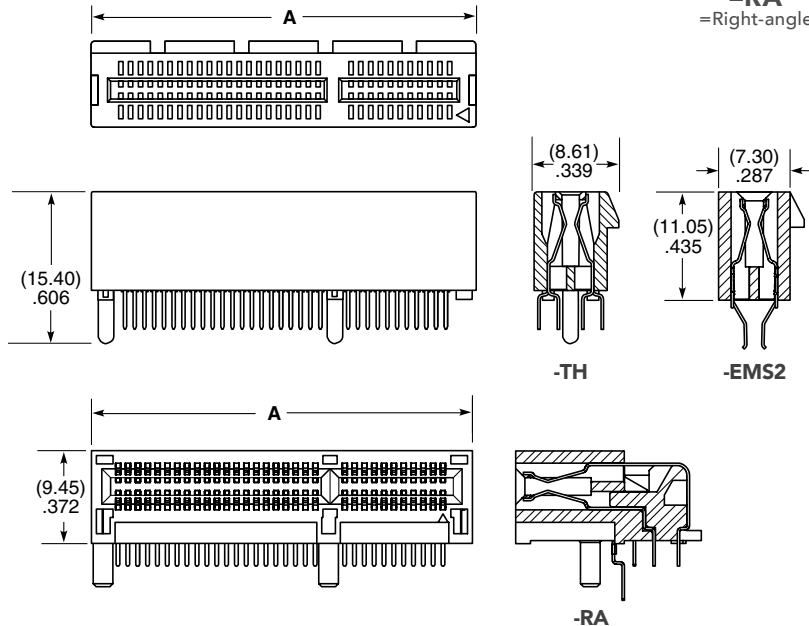

View complete specifications at: samtec.com?PCIE

PCIE - **LP** - **NUMBER OF LANES** - **01** - **PLATING OPTION** - **DV** - **A** - **OPTION** - **PACKAGING**

**-01, -04,
-08, -16**

-F
= Gold Flash on
contact, Matte
Tin on tail

-S
= 30 μ" (0.75 μm)
Gold on contact,
Matte Tin on tail

-WT
= Weld Tab

-K
= Polyimide film
Pick & Place Pad

(For -16 lanes
only leave blank for
Tray Packaging)

-TR
= Tape & Reel
("X"R required with
-01, -04, -08 lanes)

-FR
= Full Reel
Tape & Reel
(must order max.
quantity per reel;
contact Samtec for
quantity breaks)
("X"R required with
-01, -04, -08 lanes)

PCIE-LP

Card Mates:
(1.60 mm)
.062" card
Cable Mates:
PCIEC

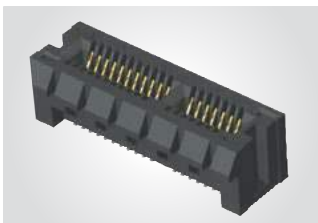

PCI-SIG®, PCI Express® and the PCIe® design marks are registered trademarks and/or service marks of PCI-SIG.

Note:
Some lengths, styles and options are non-standard, non-returnable.

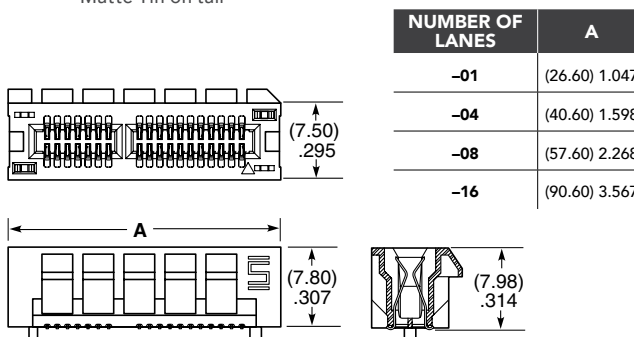

NUMBER OF LANES	A
-01	(26.60) 1.047
-04	(40.60) 1.598
-08	(57.60) 2.268
-16	(90.60) 3.567

View complete specifications at: samtec.com?PCIE-LP