

**PANEL CUT OUT**

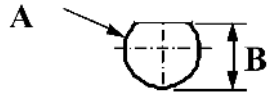

inches		
	Maxi	mini
<b>A</b>	<b>.198</b>	<b>.192</b>
<b>B</b>	<b>.183</b>	<b>.177</b>

REVISIONS			
REV.	DESCRIPTION	DATE	APPROVED
A	INITIAL RELEASE	04/16/18	C.E.

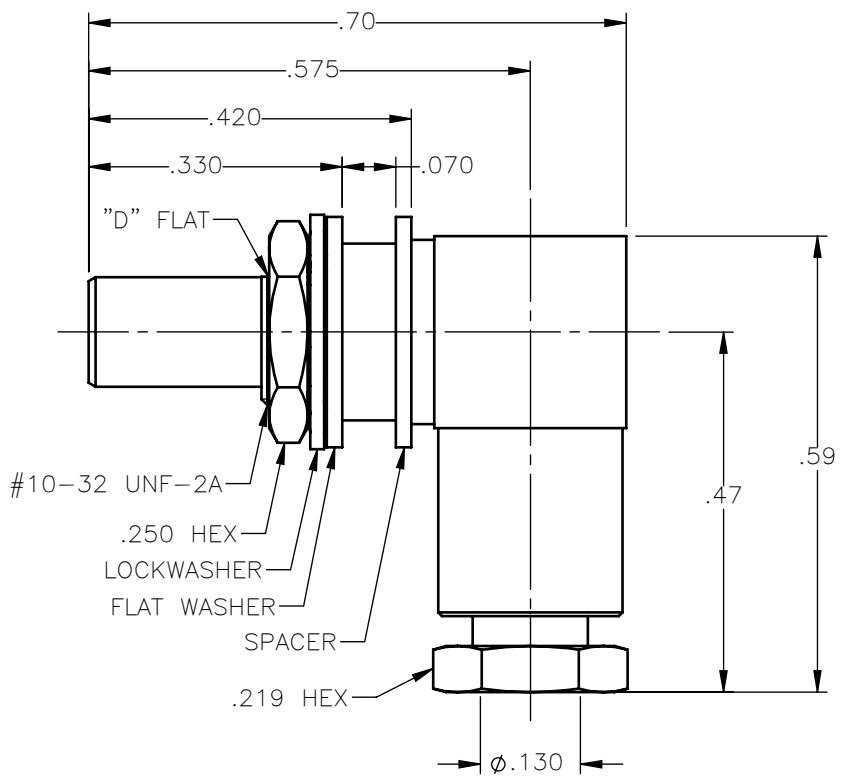



NOTES:

MATERIALS:

1. INSULATORS = VIRGIN WHITE TEFLON PER ASTM D1710, GRADE 1, TYPE I, CLASS "B".
2. LOCKWASHER = PHOSPHOR BRONZE PER ASTM B139, COPPER ALLOY C53400, TEMPER H04.
3. ALL OTHER METAL PARTS = BRASS PER ASTM B16, ALLOY C36000, TEMPER H02.

FINISHES:

1. CONTACT = GOLD PLATE PER ASTM B488-11, TYPE II, 50 $\mu$ in MIN, GRADE C, OVER 100 TO 200 $\mu$ in STRESS FREE SULFAMATE NICKEL PER AMS-QQ-N-290.
2. ALL OTHER METAL PARTS = GOLD PLATE PER ASTM B488-11, TYPE II, 30 $\mu$ in MIN, GRADE C OVER 100 TO 200 $\mu$ in COPPER STRIKE PER AMS 2418.

UNLESS OTHERWISE SPECIFIED DIMENSIONS ARE IN INCHES TOLERANCES ON	DWN: C.E.	DATE: 04/16/18	 Property of Radiall This document cannot be reproduced or communicated to a third party without prior written permission of RADIALL.		
	CHKD: D.N.	DATE: 04/16/18			
DECIMAL	ANGLE	APVD: J.M.	DATE: 04/16/18	<b>SLB RIGHT ANGLE MALE JACK BULKHEAD/FLOAT MOUNT CLAMP TYPE FOR RG-316DS &amp; SIMILAR CABLES</b>	
REFERENCE:	MATERIALS & FINISHES:	SIZE: A	FSCM NO.: 19505		DWG NO.: 3006-1551-619
ORIGINATED: C.E. DATE: 04/16/18	SEE NOTES	SCALE: 4:1	THIRD ANGLE PROJECTION		REV: A
			SHEET 1 OF 1		

3006-1551-619