

## OD- RAM HOLE PATTERN (CONNECTOR SIDE)

THIS DRAWING CONTAINS INFORMATION THAT IS PROPRIETARY TO MOLEX ELECTRONIC TECHNOLOGIES, LLC AND SHOULD NOT BE USED WITHOUT WRITTEN PERMISSION											
DIMENSION UNITS	SCALE	CURRENT REV DESC: MIGRATED TO NX								molex	
mm	NTS									IMPACT ORTHOGONAL DIRECT 6 PAIR RAM 90 & 270 ASSY BOTTOM GUIDE SALES DWG	
GENERAL TOLERANCES (UNLESS SPECIFIED)										PRODUCT CUSTOMER DRAWING	
ANGULAR TOL ± 0.5°		EC NO: 705090		2018/09/19		DOCUMENT NUMBER		DOC TYPE		DOC PART	
4 PLACES ±		DRWN: AAPPAROTHAKK		2022/02/17		SD-171576-0003		PSD		001 B3	
3 PLACES ±		CHK'D: VINODM3		2022/05/13							
2 PLACES ± 0.13		APPR: LZENG		2022/05/13		MATERIAL NUMBER		CUSTOMER		SHEET NUMBER	
1 PLACE ± 0.25		INITIAL REVISION:		2012/04/13		SEE TABLE		GENERAL MARKET		1 OF 4	
0 PLACES ±		DRWN: JMENDOZA		2012/12/03							
DRAFT WHERE APPLICABLE MUST REMAIN WITHIN DIMENSIONS		THIRD ANGLE PROJECTION		DRAWING		SERIES					
				C-SIZE		171576					

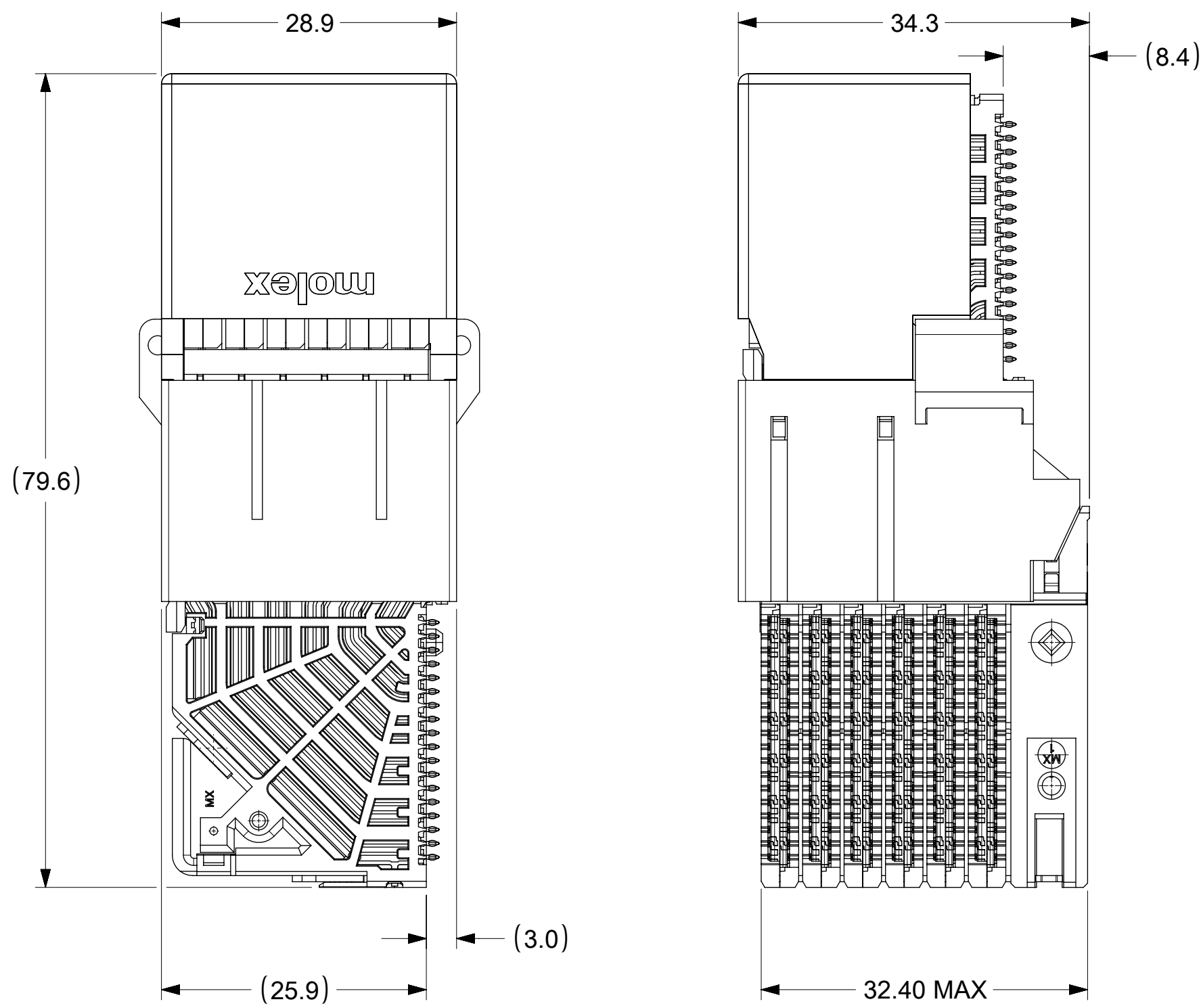

**171576-92\*\***

MODULE TYPE  
9 = BOTTOM GUIDED, TIN

# OF COLUMNS  
2 = 12 COLUMN

PIN LENGTH (P)  
4 = 4.90 (0.46 PTH)  
5 = 5.50 (0.46 PTH)  
7 = 4.90 (0.39 PTH)  
8 = 5.50 (0.39 PTH)

MATE POSITION  
0 = 90 DEGREE  
3 = 270 DEGREE

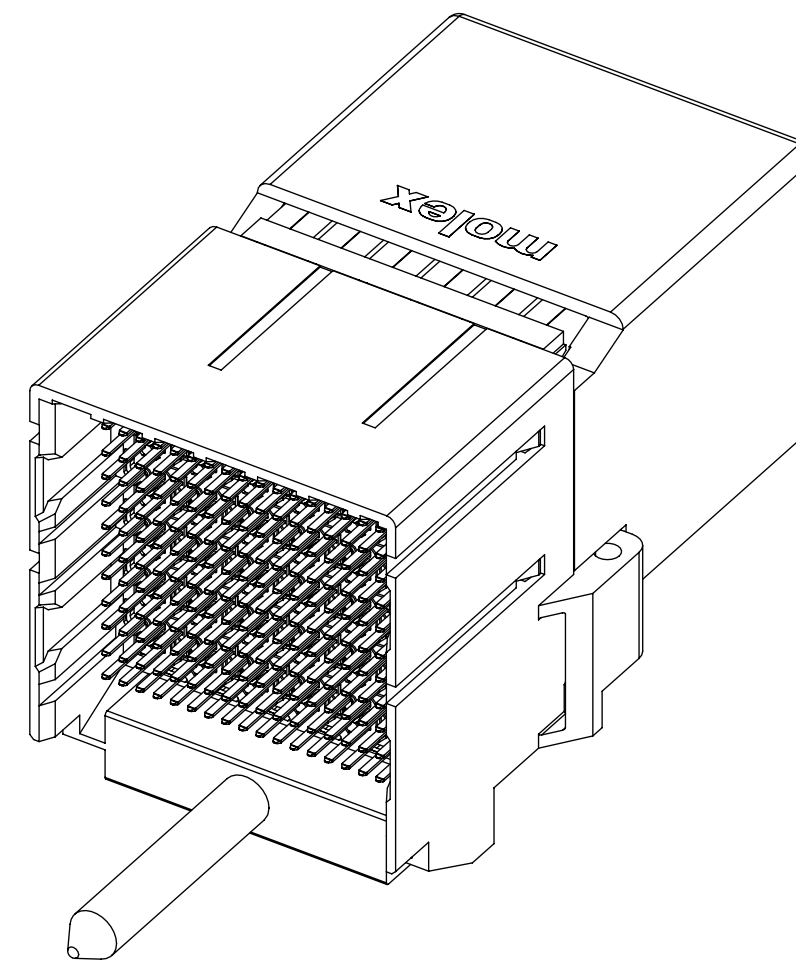

## MATED DIMENSIONS (POSITION 90° SHOWN)

### NOTES:

- MATERIALS: HOUSING - LIQUID CRYSTAL POLYMER (LCP)  
GLASS-FILLED, UL94V-0  
TERMINALS - HIGH PERFORMANCE COPPER ALLOY
- FINISH: 30μ MIN GOLD IN CONTACT AREA.  
SELECTIVE TIN ON PCB TAILS.  
NICKEL OVERALL.
- REFER TO MOLEX PRODUCT SPECIFICATION PS-76060-999  
FOR PERFORMANCE SPECIFICATIONS AND ADDITIONAL PCB INFORMATION.
- THIS PART CONFORMS TO CLASS B REQUIREMENTS OF  
COSMETIC SPEC PS-45499-002.
- PACKAGE PER: PK-70873-8025.
- SEE SHEETS 3 AND 4 FOR ORTHOGONAL PIN MAPPING.
- REFER TO SHEET 3 AND 4 FOR THE MATING RECEPTACLES.
- REFER TO MOLEX ROUTING GUIDE AS-76850-990 FOR ADDITIONAL PCB LAYOUT  
AND ROUTING RECOMMENDATIONS.
- CONNECTORS ARE SUPPLIED WITH TWO 2-32 THREAD FORMING  
SCREWS.
- THESE DIMENSIONS REPRESENT THE AREA NEEDED TO ACCOMODATE CONNECTOR  
INSERTION AND REPAIR ON THE PC BOARD. THIS IS REFERRED TO AS THE  
"CONNECTOR KEEP OUT ZONE" AND DOES NOT REPRESENT THE ACTUAL PERIMETER  
OF THE CONNECTOR.
- MARKING: LOCATED APPROXIMATELY AS SHOWN, ON BOTTOM OR TOP HOUSING.  
PART NUMBER AND DATE CODE.

THIS DRAWING CONTAINS INFORMATION THAT IS PROPRIETARY TO MOLEX ELECTRONIC TECHNOLOGIES, LLC AND SHOULD NOT BE USED WITHOUT WRITTEN PERMISSION									
DIMENSION UNITS	SCALE	CURRENT REV DESC: MIGRATED TO NX							
mm	NTS					IMPACT ORTHOGONAL DIRECT 6 PAIR RAM 90 & 270 ASSY BOTTOM GUIDE SALES DWG			
GENERAL TOLERANCES (UNLESS SPECIFIED)		EC NO: 705090				PRODUCT CUSTOMER DRAWING			
ANGULAR TOL	± 0.5°	DRWN: AAPPAROTHAKK 2018/09/19				DOCUMENT NUMBER			
4 PLACES	±	CHK'D: VINODM3 2022/02/17				SD-171576-0003			
3 PLACES	±	APPR: LZENG 2022/05/13				DOC TYPE DOC PART REVISION			
2 PLACES	± 0.13	INITIAL REVISION:				PSD 001 B3			
1 PLACE	± 0.25	DRWN: JMENDOZA 2012/04/13				MATERIAL NUMBER			
0 PLACES	±	APPR: JMENDOZA 2012/12/03				CUSTOMER			
DRAFT WHERE APPLICABLE MUST REMAIN WITHIN DIMENSIONS		THIRD ANGLE PROJECTION		DRAWING	SERIES	SHEET NUMBER		2 OF 4	
				C-SIZE	171576	SEE TABLE	GENERAL MARKET		

# ORTHO POSITION 90°

OD-RAM PIN A1 MAPS  
TO RAF PIN T12

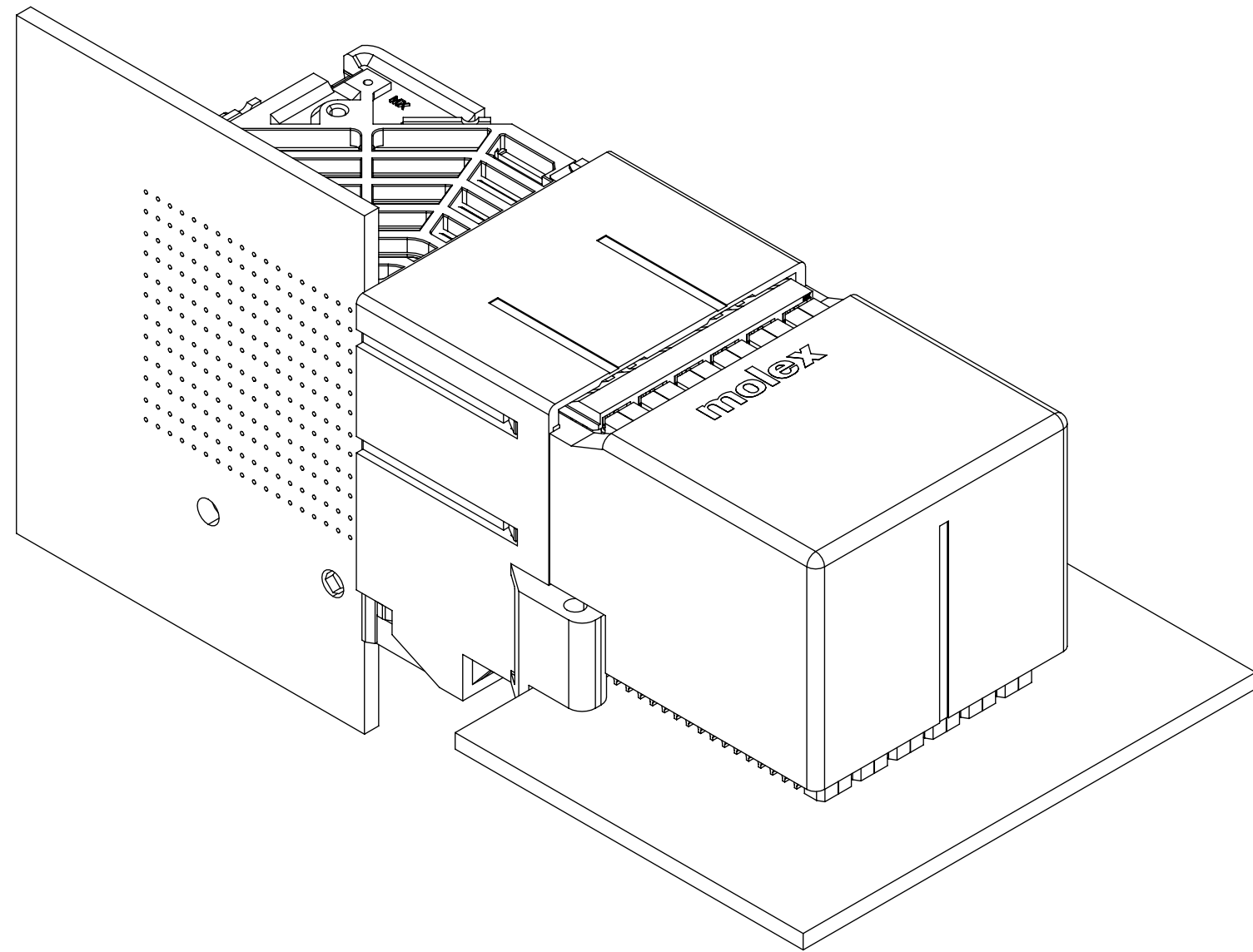

REFER TO MOLEX SALES DRAWING SD-76290-004  
FOR MATING RECEPTACLES.

## ORTHO PIN MAPPING

### OPTION 90 (NEAR SIDE - FAR SIDE)

A1-T12	A2-S12	A3-Q12	A4-P12	A5-M12	A6-L12	A7-J12	A8-H12	A9-F12	A10-E12	A11-C12	A12-B12
B1-T11	B2-R12	B3-Q11	B4-N12	B5-M11	B6-K12	B7-J11	B8-G12	B9-F11	B10-D12	B11-C11	B12-A12
C1-S11	C2-R11	C3-P11	C4-N11	C5-L11	C6-K11	C7-H11	C8-G11	C9-E11	C10-D11	C11-B11	C12-A11
D1-T10	D2-S10	D3-Q10	D4-P10	D5-M10	D6-L10	D7-J10	D8-H10	D9-F10	D10-E10	D11-C10	D12-B10
E1-T9	E2-R10	E3-Q9	E4-N10	E5-M9	E6-K10	E7-J9	E8-G10	E9-F9	E10-D10	E11-C9	E12-A10
F1-S9	F2-R9	F3-P9	F4-N9	F5-L9	F6-K9	F7-H9	F8-G9	F9-E9	F10-D9	F11-B9	F12-A9
G1-T8	G2-S8	G3-Q8	G4-P8	G5-M8	G6-L8	G7-J8	G8-H8	G9-F8	G10-E8	G11-C8	G12-B8
H1-T7	H2-R8	H3-Q7	H4-N8	H5-M7	H6-K8	H7-J7	H8-G8	H9-F7	H10-D8	H11-C7	H12-A8
J1-S7	J2-R7	J3-P7	J4-N7	J5-L7	J6-K7	J7-H7	J8-G7	J9-E7	J10-D7	J11-B7	J12-A7
K1-T6	K2-S6	K3-Q6	K4-P6	K5-M6	K6-L6	K7-J6	K8-H6	K9-F6	K10-E6	K11-C6	K12-B6
L1-T5	L2-R6	L3-Q5	L4-N6	L5-M5	L6-K6	L7-J5	L8-G6	L9-F5	L10-D6	L11-C5	L12-A6
M1-S5	M2-R5	M3-P5	M4-N5	M5-L5	M6-K5	M7-H5	M8-G5	M9-E5	M10-D5	M11-B5	M12-A5
N1-T4	N2-S4	N3-Q4	N4-P4	N5-M4	N6-L4	N7-J4	N8-H4	N9-F4	N10-E4	N11-C4	N12-B4
P1-T3	P2-R4	P3-Q3	P4-N4	P5-M3	P6-K4	P7-J3	P8-G4	P9-F3	P10-D4	P11-C3	P12-A4
Q1-S3	Q2-R3	Q3-P3	Q4-N3	Q5-L3	Q6-K3	Q7-H3	Q8-G3	Q9-E3	Q10-D3	Q11-B3	Q12-A3
R1-T2	R2-S2	R3-Q2	R4-P2	R5-M2	R6-L2	R7-J2	R8-H2	R9-F2	R10-E2	R11-C2	R12-B2
S1-T1	S2-R2	S3-Q1	S4-N2	S5-M1	S6-K2	S7-J1	S8-G2	S9-F1	S10-D2	S11-C1	S12-A2
T1-S1	T2-R1	T3-P1	T4-N1	T5-L1	T6-K1	T7-H1	T8-G1	T9-E1	T10-D1	T11-B1	T12-A1

NOTE: PINOUTS SHOWN IN BALLOONS ARE GROUNDS.  
GROUND PATHS ARE NOT DISCRETE CIRCUITS.

MATERIAL NUMBER	# OF COLUMNS	# OF DIFF PAIR	MATE POSITION	DIM P	PTH Ø
171576-9204	12	72	90	4.90	0.46±0.05
171576-9205	12	72	90	5.50	0.46±0.05
171576-9207	12	72	90	4.90	0.39±0.05
171576-9208	12	72	90	5.50	0.39±0.05

THIS DRAWING CONTAINS INFORMATION THAT IS PROPRIETARY TO MOLEX ELECTRONIC TECHNOLOGIES, LLC AND SHOULD NOT BE USED WITHOUT WRITTEN PERMISSION

DIMENSION UNITS	SCALE	CURRENT REV DESC: MIGRATED TO NX				
mm	NTS					
GENERAL TOLERANCES (UNLESS SPECIFIED)		EC NO: 705090		IMPACT ORTHOGONAL DIRECT 6 PAIR RAM 90 & 270 ASSY BOTTOM GUIDE SALES DWG		
ANGULAR TOL	± 0.5°	DRWN: AAPPAROTHAKK 2018/09/19				
4 PLACES	±	CHK'D: VINODM3 2022/02/17		PRODUCT CUSTOMER DRAWING		
3 PLACES	±	APPR: LZENG 2022/05/13				
2 PLACES	± 0.13	INITIAL REVISION:		DOCUMENT NUMBER		
1 PLACE	± 0.25	DRWN: JMENDOZA 2012/04/13				
0 PLACES	±	APPR: JMENDOZA 2012/12/03		DOC TYPE		
DRAFT WHERE APPLICABLE MUST REMAIN WITHIN DIMENSIONS		THIRD ANGLE PROJECTION	DRAWING			
			C-SIZE	171576	CUSTOMER	
					GENERAL MARKET	
					SHEET NUMBER	
					3 OF 4	

# ORTHO POSITION 270°

OD-RAM PIN A1 MAPS  
TO RAF PIN A1

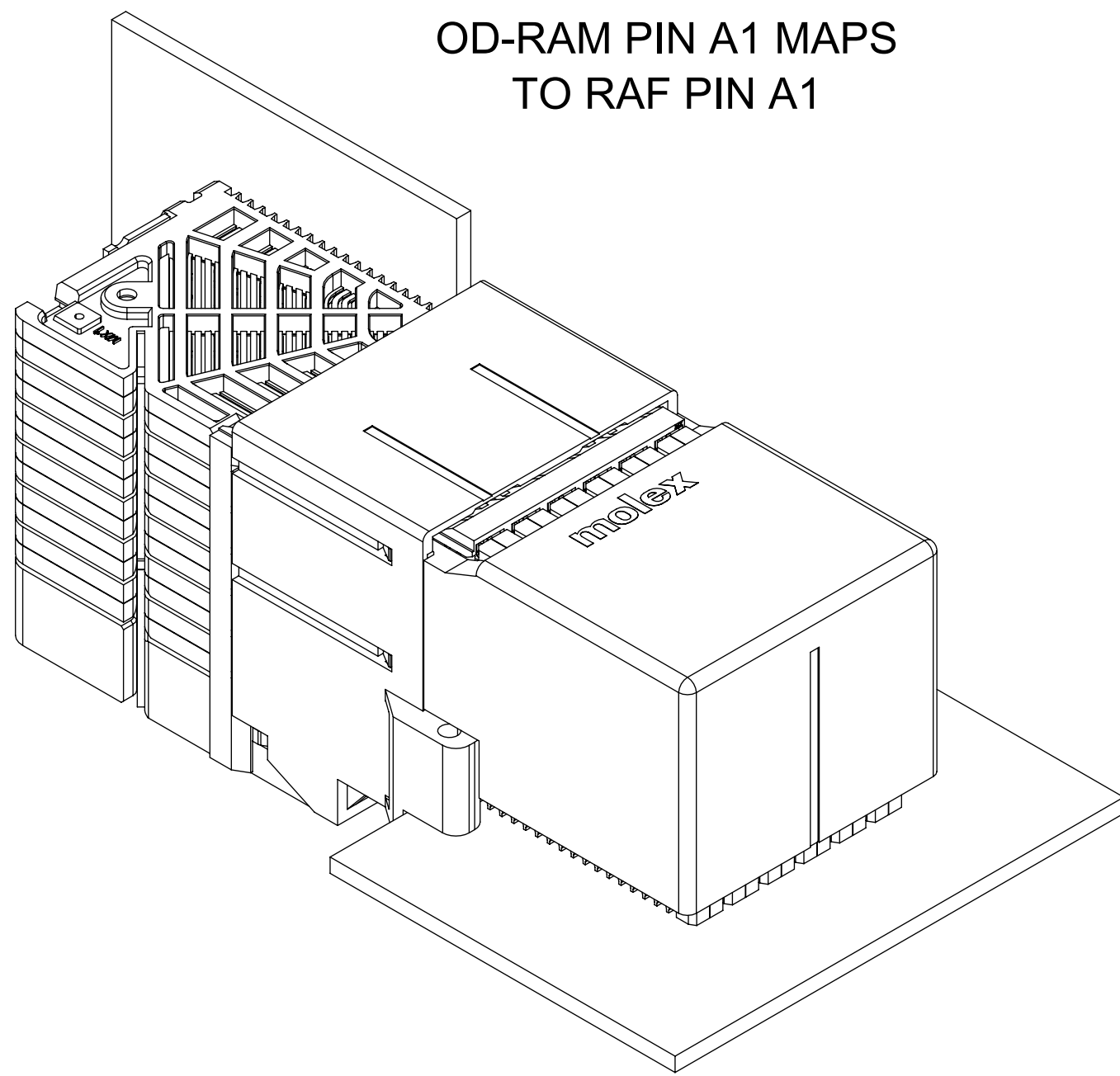

REFER TO MOLEX SALES DRAWING SD-76290-002  
FOR MATING RECEPTACLES.

## ORTHO PIN MAPPING

### OPTION 270 (NEARSIDE - FAR SIDE)

A1-A1	A2-B1	A3-D1	A4-E1	A5-G1	A6-H1	A7-K1	A8-L1	A9-N1	A10-P1	A11-R1	A12-S1
B1-A2	B2-C1	B3-D2	B4-F1	B5-G2	B6-J1	B7-K2	B8-M1	B9-N2	B10-Q1	B11-R2	B12-T1
C1-B2	C2-C2	C3-E2	C4-F2	C5-H2	C6-J2	C7-L2	C8-M2	C9-P2	C10-Q2	C11-S2	C12-T2
D1-A3	D2-B3	D3-D3	D4-E3	D5-G3	D6-H3	D7-K3	D8-L3	D9-N3	D10-P3	D11-R3	D12-S3
E1-A4	E2-C3	E3-D4	E4-F3	E5-G4	E6-J3	E7-K4	E8-M3	E9-N4	E10-Q3	E11-R4	E12-T3
F1-B4	F2-C4	F3-E4	F4-F4	F5-H4	F6-J4	F7-L4	F8-M4	F9-P4	F10-Q4	F11-S4	F12-T4
G1-A5	G2-B5	G3-D5	G4-E5	G5-G5	G6-H5	G7-K5	G8-L5	G9-N5	G10-P5	G11-R5	G12-S5
H1-A6	H2-C5	H3-D6	H4-F5	H5-G6	H6-J5	H7-K6	H8-M5	H9-N6	H10-Q5	H11-R6	H12-T5
J1-B6	J2-C6	J3-E6	J4-F6	J5-H6	J6-J6	J7-L6	J8-M6	J9-P6	J10-Q6	J11-S6	J12-T6
K1-A7	K2-B7	K3-D7	K4-E7	K5-G7	K6-H7	K7-K7	K8-L7	K9-N7	K10-P7	K11-R7	K12-S7
L1-A8	L2-C7	L3-D8	L4-F7	L5-G8	L6-J7	L7-K8	L8-M7	L9-N8	L10-Q7	L11-R8	L12-T7
M1-B8	M2-C8	M3-E8	M4-F8	M5-H8	M6-J8	M7-L8	M8-M8	M9-P8	M10-Q8	M11-S8	M12-T8
N1-A9	N2-B9	N3-D9	N4-E9	N5-G9	N6-H9	N7-K9	N8-L9	N9-N9	N10-P9	N11-R9	N12-S9
P1-A10	P2-C9	P3-D10	P4-F9	P5-G10	P6-J9	P7-K10	P8-M9	P9-N10	P10-Q9	P11-R10	P12-T9
Q1-B10	Q2-C10	Q3-E10	Q4-F10	Q5-H10	Q6-J10	Q7-L10	Q8-M10	Q9-P10	Q10-Q10	Q11-S10	Q12-T10
R1-A11	R2-B11	R3-D11	R4-E11	R5-G11	R6-H11	R7-K11	R8-L11	R9-N11	R10-P11	R11-R11	R12-S11
S1-A12	S2-C11	S3-D12	S4-F11	S5-G12	S6-J11	S7-K12	S8-M11	S9-N12	S10-Q11	S11-R12	S12-T11
T1-B12	T2-C12	T3-E12	T4-F12	T5-H12	T6-J12	T7-L12	T8-M12	T9-P12	T10-Q12	T11-S12	T12-T12

NOTE: PINOUTS SHOWN IN BALLOONS ARE GROUNDS.  
GROUND PATHS ARE NOT DISCRETE CIRCUITS.

MATERIAL NUMBER	# OF COLUMNS	# OF DIFF PAIR	MATE POSITION	DIM P	PTH Ø
171576-9234	12	72	270	4.90	0.46±0.05
171576-9235	12	72	270	5.50	0.46±0.05
171576-9237	12	72	270	4.90	0.39±0.05
171576-9238	12	72	270	5.50	0.39±0.05

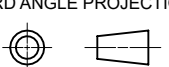
THIS DRAWING CONTAINS INFORMATION THAT IS PROPRIETARY TO MOLEX ELECTRONIC TECHNOLOGIES, LLC AND SHOULD NOT BE USED WITHOUT WRITTEN PERMISSION											
DIMENSION UNITS		SCALE		CURRENT REV DESC: MIGRATED TO NX				 <p>IMPACT ORTHOGONAL DIRECT 6 PAIR RAM 90 &amp; 270 ASSY BOTTOM GUIDE SALES DWG</p>			
mm		NTS									
GENERAL TOLERANCES (UNLESS SPECIFIED)				EC NO: 705090				PRODUCT CUSTOMER DRAWING			
ANGULAR TOL ± 0.5°				DRWN: AAPPAROTHAKK 2018/09/19							
4 PLACES ±				CHK'D: VINODM3 2022/02/17				DOCUMENT NUMBER			
3 PLACES ±				APPR: LZENG 2022/05/13							
2 PLACES ± 0.13				INITIAL REVISION:				SD-171576-0003			
1 PLACE ± 0.25				DRWN: JMENDOZA 2012/04/13							
0 PLACES ±				APPR: JMENDOZA 2012/12/03				DOC TYPE DOC PART REVISION			
DRAFT WHERE APPLICABLE MUST REMAIN WITHIN DIMENSIONS				THIRD ANGLE PROJECTION		DRAWING		SERIES		MATERIAL NUMBER	
						C-SIZE		171576		CUSTOMER	
								GENERAL MARKET		SHEET NUMBER	
								SEE TABLE		4 OF 4	