

THIS COPY IS PROVIDED ON A RESTRICTED BASIS AND IS NOT TO BE USED IN ANY WAY DETRIMENTAL TO THE INTERESTS OF PANDUIT CORP.

PANDUIT P/N	WEIGHT
CFPE6**Y	.67 LB/10 PCS 303.9 g/10 PCS)

NOTES:

1. SEE CURRENT CATALOG FOR ADDITIONAL PART NUMBER SUFFIXES TO INDICATE COLOR AND OR PACKAGE QUANTITY.
2. SEE CATALOG FOR COMPLETE LIST OF PARTS APPLICABLE FOR USE WITH THIS PART.
3. DIMENSIONS IN [] ARE IN METRIC.
4. PART INCLUDES:
1- FACEPLATE
2- LABEL
2- LABEL COVER
2- MOUNTING SCREW

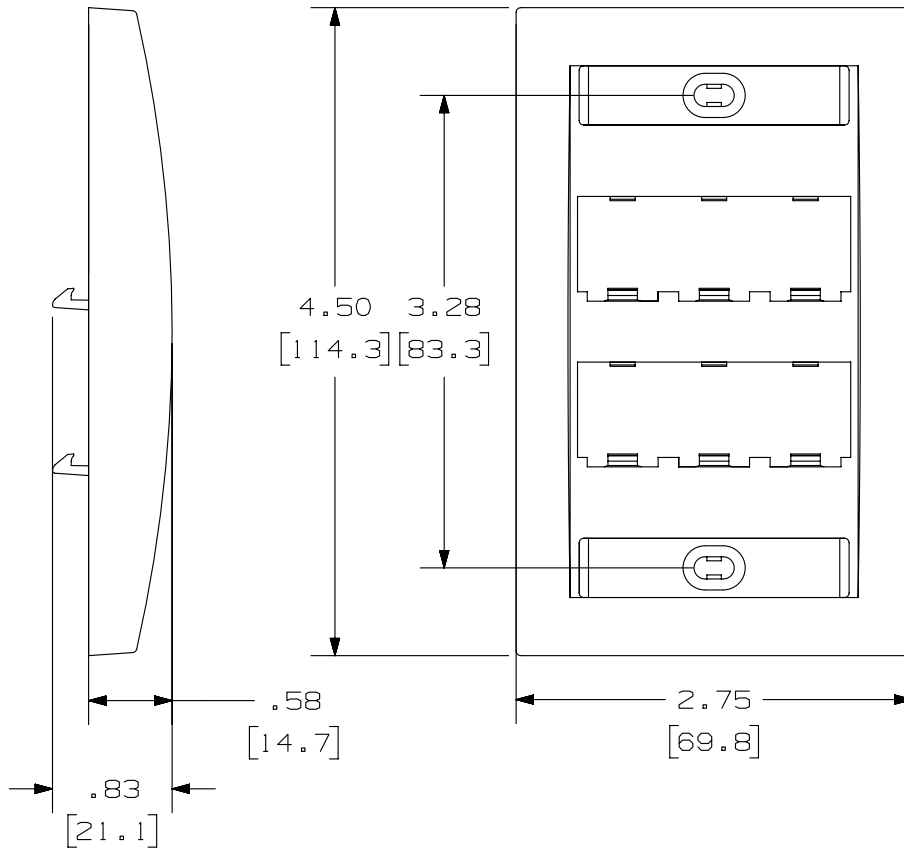

PART NUMBER		CFPE6**Y	
TITLE			
MINI-COM 6 POSITION EXECUTIVE		SERIES FACEPLATE	
CUSTOMER DRAWING			
ITEM REVISION NAME		M02479EM/00	
DATASET FILE NAME		M02479EM_DC119/00A	
UNLESS OTHERWISE SPECIFIED, DIMENSIONAL TOLERANCES ARE: IN [mm]		MATERIAL:	
.x ± .xx ± .03 [.8]		.xxx ± .010 [.3]	
ANGLES ±		ABS	
DRAWN BY		DRAWING NUMBER:	
JSP		02479-119	
DATE		SCALE	
4/2/14		NONE	
CHK		SHT 1 OF 1	
MJD		A	
THIRD ANGLE PROJECTION			

REV	DATE	BY	CHK	APR	DESCRIPTION	ECN
1	4/214	JSP	REFR	MMR	A. REVISED DRAWING TITLE BLOCK.	02479-119
R	4-26-06	JSP	MJD	MJD	RELEASED TO PRODUCTION	02479-119

D10100DA/14