

SERPAC C6

Electronic Enclosures

NOTES:

1) When machine or I-plates modifications are required, use the center of the enclosure to dimension.

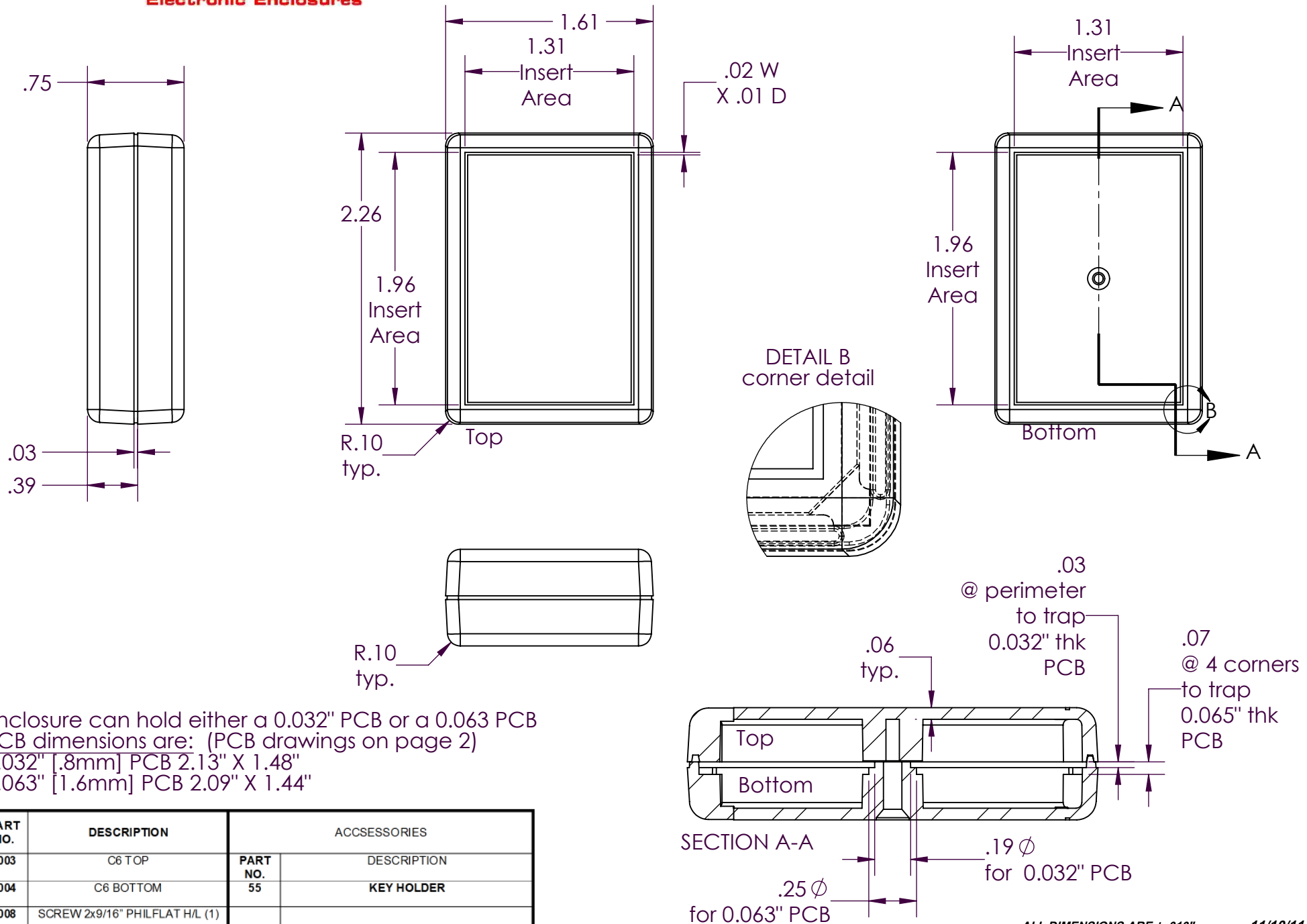

Enclosure can hold either a 0.032" PCB or a 0.063 PCB
 PCB dimensions are: (PCB drawings on page 2)
 0.032" [.8mm] PCB 2.13" X 1.48"
 0.063" [1.6mm] PCB 2.09" X 1.44"

PART NO.	DESCRIPTION	ACCESSORIES	
1003	C6 TOP	PART NO.	DESCRIPTION
1004	C6 BOTTOM	55	KEY HOLDER
6008	SCREW 2x9/16" PHILFLAT H/L (1)		

SERPAC CIRCUIT BOARD C6

Electronic Enclosures

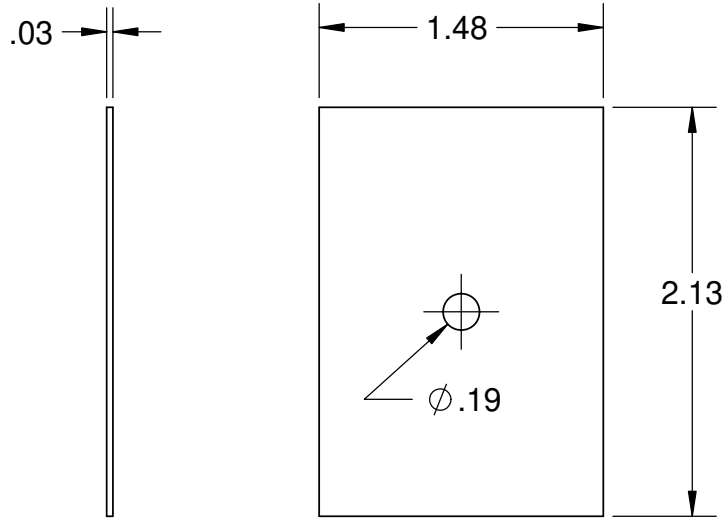

.032 board

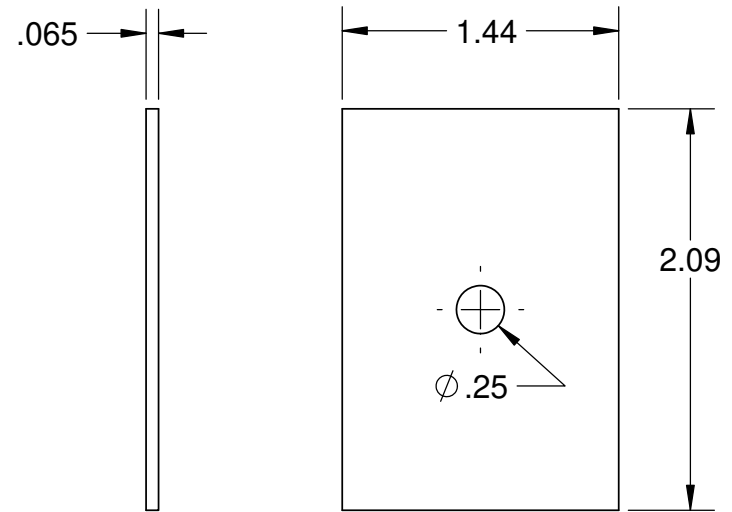

.065 board

NOTES:
These are suggested dimensions.
Plastic parts have a ± 0.010 " manufacturing tolerance.