

THIS DRAWING IS UNPUBLISHED. RELEASED FOR PUBLICATION  
 © COPYRIGHT BY TYCO ELECTRONICS CORPORATION. ALL RIGHTS RESERVED.

DESIGNED FOR USE WITH .085 SR CABLE	
CABLE ENTRY DIAMETER MINIMUM	
HOUSING	.089
DIELECTRIC	.049
CONTACT	.022

LOC		DIST		REVISIONS			
AJ	00	P	LTR	DESCRIPTION	DATE	DWN	APVD
		B		REV PER ECO 07-004710	3-02-2007	DW	KW

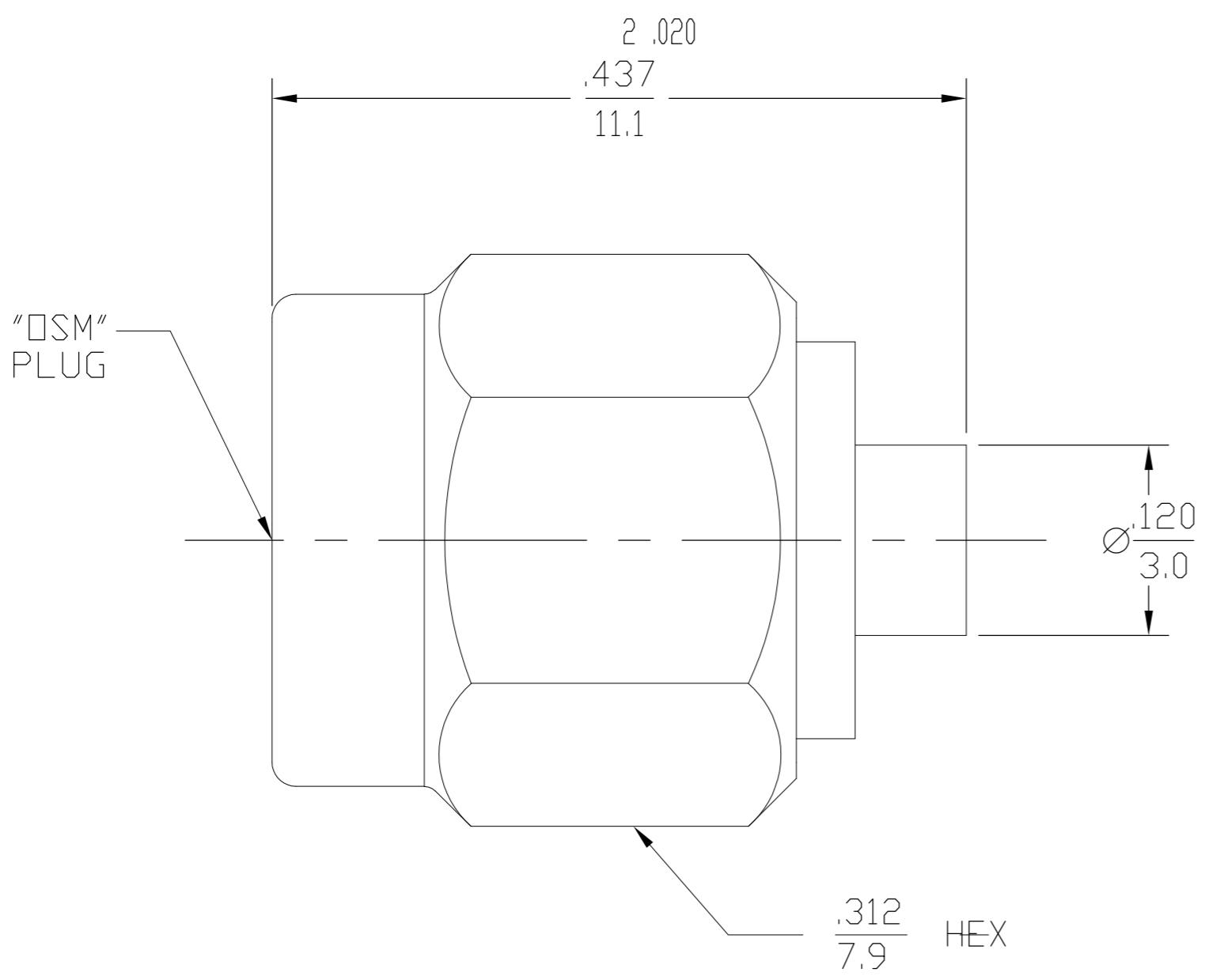

1056232-1  
PART NUMBER

ELECTRICAL	MECHANICAL	ENVIRONMENTAL
Nominal Impedance (Ohms) 50	Interface Dimensions MIL-STD-348, Fig. 310.1	TEMPERATURE RATING -65°C TO 105°C
Frequency Range (GHz) DC to 27	Recommended Mating Torque 7 to 10 in-LBs	Vibration MIL-STD-202, Method 204, Condition D
Volt Rating (VRMS MAX) @ Sea Level 335	Mating Characteristics: Insertion (MAX Lbs) N/A	Shock MIL-STD-202, Method 213, Condition I
VSWR 1.05 + .005f(GHz)	Withdrawal (MIN Oz) N/A	Thermal Shock MIL-STD-202, Method 107, Condition B, EXCEPT HIGH TEMP 115°C
Insertion Loss (dB MAX) .05 √f(GHz)	Force to Engage and Disengage (In/Lbs MAX) 2.0	Moisture Resistance MIL-STD-202, Method 106
RF Leakage (dB MIN) -(90-f(GHz))	Center Contact Captivation Axial (Lbs) N/A	Corrosion - MIL-STD-202, Method 101, Condition B, 5% salt spray
Corona, 70,000 Ft (VRMS MIN) 250	Cable Retention Axial Force (Lbs) 30	
Dielectric Withstanding Voltage (VRMS MIN) @ Sea Level 1000	Torque (In/Oz) 16	
Contact Resistance (Milliohms MAX) Center Contact 2.0	Weight (Grams) T.B.D.	
Outer Contact 2.0		
Cable to Housing 0.5		
RF High Potential @ Sea Level (VRMS MIN @ 5 MHz) 670		
I.R.(Megohms MIN) 10,000		

COMPONENT	MATERIAL	FINISH
HOUSING COUPLING NUT	STAINLESS STEEL PER ASTM-A484 AND ASTM-A582, TYPE 303	GOLD PLATE PER MIL-G-45204
DIELECTRIC	PTFE FLUOROCARBON PER ASTM-D-1457	N/A
CENTER CONTACT	BERYLLIUM COPPER PER ASTM-B-196 OR ASTM-B-197, ALLOY C17300, CONDITION H OR BRASS PER ASTM-B-16	GOLD PLATE PER MIL-G-45204
RETAINING RING	BERYLLIUM COPPER PER ASTM-B-194, ALLOY C17200, CONDITION H	N/A
GASKET	SILICONE RUBBER PER ZZ-R-765	N/A

.XXX = in  
XX.X = mm (REF)

THIS DRAWING IS A CONTROLLED DOCUMENT.		DWN RR 5-02-79	<b>tyco</b> Electronics		Tyco Electronics Corporation Harrisburg, PA 17105-3608	
DIMENSIONS: INCHES		CHK CGH 5-11-79				
TOLERANCES UNLESS OTHERWISE SPECIFIED:		APVD GH 5-11-79	NAME		OSM 27 GHz STRAIGHT CABLE PLUG-DIRECT SOLDER ATTACHMENT	
0 PLC ± -		PRODUCT SPEC	SIZE		CAGE CODE	
1 PLC ± -		APPLICATION SPEC	DRAWING NO		RESTRICTED TO	
2 PLC ± -			A2		00779	
3 PLC ± -			C=1056232		-	
4 PLC ± -			SCALE 8:1		SHEET 1 of 1	
ANGLES ± -			CUSTOMER DRAWING		REV B	
MATERIAL		FINISH	WEIGHT			