

## HFBR-1312TZ Transmitter

## HFBR-2316TZ Receiver

1300 nm Fiber Optic Transmitter and Receiver



## Data Sheet



### Description

The HFBR-1312TZ Transmitter and HFBR-2316TZ Receiver are designed to provide the most cost-effective 1300 nm fiber optic links for a wide variety of data communication applications from low-speed distance extenders up to SONET OC-3 signal rates. Pinouts identical to Avago HFBR-0400Z Series allow designers to easily upgrade their 820 nm links for farther distance. The transmitter and receiver are compatible with two popular optical fiber sizes: 50/125  $\mu\text{m}$  and 62.5/125  $\mu\text{m}$  diameter. This allows flexibility in choosing a fiber size. The 1300 nm wavelength is in the lower dispersion and attenuation region of fiber, and provides longer distance capabilities than 820 nm LED technology. Typical distance capabilities are 2 km at 125 MBd and 5 km at 32 MBd.

### Features

- RoHS-compliant
- Low cost fiber optic link
- Signal rates over 155 megabaud
- 1300 nm wavelength
- Link distances up to 5 km
- Dual-in-line package panel-mountable ST\* port
- Auto-insertable and wave-solderable
- Specified with 62.5/125  $\mu\text{m}$  and 50/125  $\mu\text{m}$  fiber
- Compatible with 820 nm Miniature Link Series
- Receiver also specified for SM cable spec (9/125  $\mu\text{m}$ )

### Applications

- Desktop links for high speed LANs
- Distance extension links
- Telecom switch systems
- TAXIchip® compatible

\*ST is a registered trademark of AT&T Lightguide Cable Connectors

## Transmitter

The HFBR-1312TZ fiber optic transmitter contains a 1300 nm InGaAsP light emitting diode capable of efficiently launching optical power into 50/125  $\mu\text{m}$  and 62.5/125  $\mu\text{m}$  diameter fiber. Due to the pin compatibility to the 820 nm Miniature Link Series, converting the driver circuit from a HFBR-14xxZ 820 nm transmitter to the HFBR-1312TZ requires the modification of only a few passive components.

## HFBR-1312TZ Transmitter

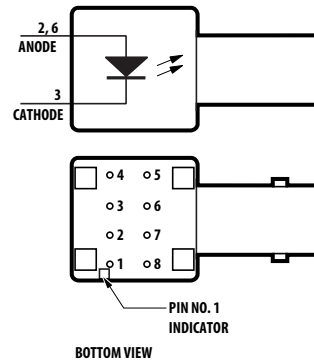

| PIN | FUNCTION |
|-----|----------|
| 1   | N.C.     |
| 2   | ANODE    |
| 3   | CATHODE  |
| 4   | N.C.     |
| 5   | N.C.     |
| 6   | ANODE    |
| 7*  | N.C.     |
| 8   | N.C.     |

\* PIN 7 IS ELECTRICALLY ISOLATED FROM PINS 1, 4, 5, AND 8, BUT IS CONNECTED TO THE HEADER.

PINS 1, 4, 5, AND 8 ARE ISOLATED FROM THE INTERNAL CIRCUITRY, BUT ARE ELECTRICALLY CONNECTED TO EACH OTHER.

## Receiver

The HFBR-2316TZ receiver contains an InGaAs PIN photodiode and a low-noise transimpedance preamplifier that operate in the 1300 nm wavelength region. The HFBR-2316TZ receives an optical signal and converts it to an analog voltage. The buffered output is an emitter-follower, with frequency response from DC to typically 125 MHz. Low-cost external components can be used to convert the analog output to logic compatible signal levels for a variety of data formats and data rates. Due to the pin compatibility to the 820 nm Miniature Link receiver HFBR-2416xxZ, converting from a 820nm to a 1300nm receiver circuit is realizable by replacing the HFBR-2416xxZ with the HFBR-2316TZ.

## HFBR-2316TZ Receiver

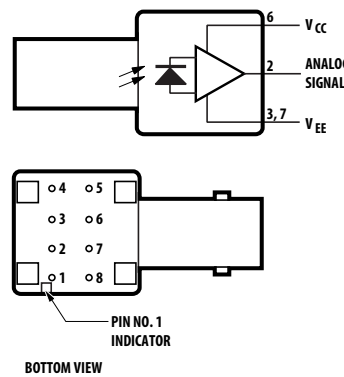

| PIN | FUNCTION        |
|-----|-----------------|
| 1   | N.C.            |
| 2   | SIGNAL          |
| 3*  | V <sub>EE</sub> |
| 4   | N.C.            |
| 5   | N.C.            |
| 6   | V <sub>CC</sub> |
| 7*  | V <sub>EE</sub> |
| 8   | N.C.            |

\* PINS 3 AND 7 ARE ELECTRICALLY CONNECTED TO THE HEADER.

PINS 1, 4, 5, AND 8 ARE ISOLATED FROM THE INTERNAL CIRCUITRY, BUT ARE ELECTRICALLY CONNECTED TO EACH OTHER.

## Mechanical Dimensions

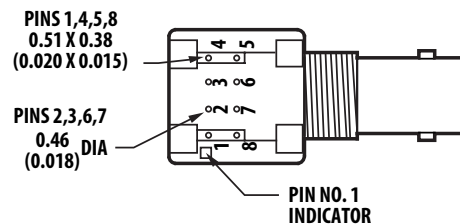
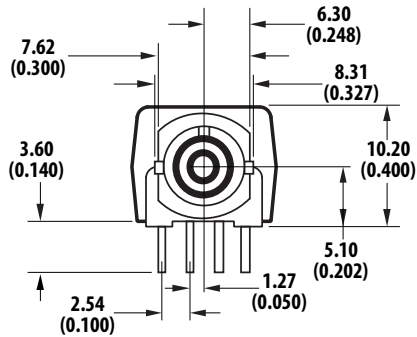
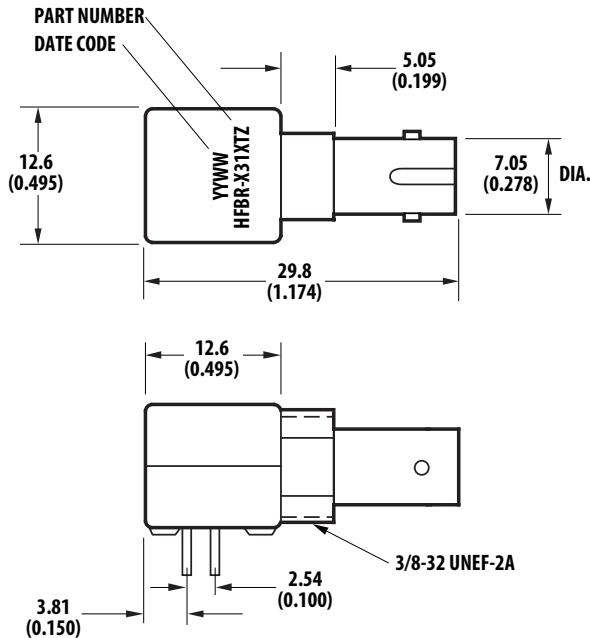

Dimensions in mm (inches)

## Package Information

The transmitter and receiver are housed in a dual-in-line package made of high strength, heat resistant, chemically resistant, and UL V-0 flame retardant plastic. The package is auto-insertable and wave solderable for high volume production applications.

Note: The "T" in the product numbers indicates a Threaded ST connector (panel mountable), for both transmitter and receiver.

## Handling and Design Information

When soldering, it is advisable to leave the protective cap on the unit to keep the optics clean. Good system performance requires clean port optics and cable ferrules to avoid obstructing the optical path. Clean compressed air is often sufficient to remove particles of dirt; methanol on a cotton swab also works well.

## Recommended Chemicals for Cleaning/Degreasing

- Alcohols (methyl, isopropyl, isobutyl)
- Aliphatics (hexane, heptane)
- Other (soap solution, naphtha)

Do not use partially halogenated hydrocarbons (such as 1.1.1 trichloroethane), ketones (such as MEK), acetone, chloroform, ethyl acetate, methylene dichloride, phenol, methylene chloride, or N-methylpyrrolidone. Also, Avago does not recommend the use of cleaners that use halogenated hydrocarbons because of their potential environmental harm.

## Panel Mounting Hardware

The HFBR-4411Z kit consists of 100 nuts and 100 washers with dimensions as shown in Figure 1. These kits are available from Avago or any authorized distributor. Any standard size nut and washer will work, provided the total thickness of the wall, nut, and washer does not exceed 0.2 inch (5.1 mm).

When preparing the chassis wall for panel mounting, use the mounting template in Figure 2. When tightening the nut, torque should not exceed 0.8 N-m (8.0 in-lb).

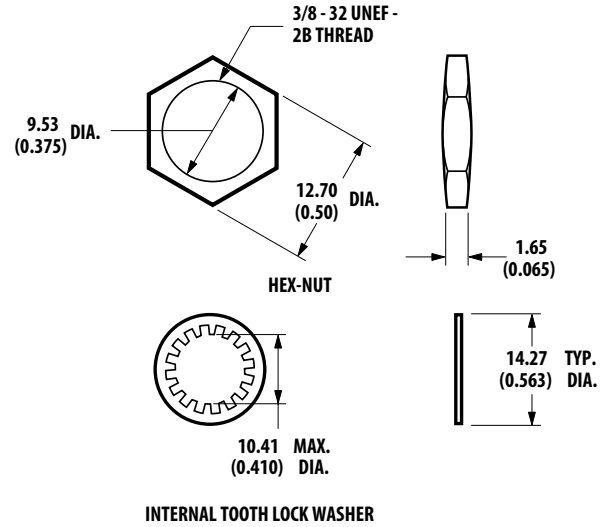

Figure 1. HFBR-4411Z mechanical dimensions

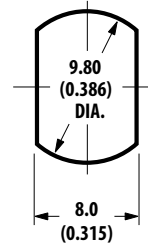

Figure 2. Recommended cut-out for panel mounting

Dimensions in mm (inches)

## HFBR-1312TZ Transmitter Absolute Maximum Ratings

| Parameter                        | Symbol    | Min. | Max. | Unit | Reference |
|----------------------------------|-----------|------|------|------|-----------|
| Storage Temperature              | $T_S$     | -55  | 85   | °C   |           |
| Operating Temperature            | $T_A$     | -40  | 85   | °C   |           |
| Lead Soldering Cycle Temperature |           |      | 260  | °C   | Note 1    |
| Lead Soldering Cycle Time        |           |      | 10   | sec  |           |
| Forward Input Current DC         | $I_{FDC}$ |      | 100  | mA   |           |
| Reverse Input Voltage            | $V_R$     |      | 1    | V    |           |

Notes:

1. 2.0 mm from where leads enter case.

**CAUTION:** The small junction sizes inherent to the design of this bipolar component increase the component's susceptibility to damage from electrostatic discharge (ESD). It is advised that normal static precautions be taken in handling and assembly of this component to prevent damage and/or degradation which may be induced by ESD.

## HFBR-1312TZ Transmitter Electrical/Optical Characteristics

0 to 70°C unless otherwise specified

| Parameter                               | Symbol                  | Min. | Typ. <sup>[2]</sup> | Max. | Unit  | Condition                | Ref.   |
|---|-------------------------|------|---------------------|------|-------|--------------------------|--------|
| Forward Voltage                         | $V_F$                   | 1.1  | 1.4                 | 1.7  | V     | $I_F = 75$ mA            | Fig. 3 |
|   |                         |      | 1.5                 |      |       | $I_F = 100$ mA           |        |
| Forward Voltage Temperature Coefficient | $\Delta V_F / \Delta T$ |      | -1.5                |      | mV/°C | $I_F = 75 - 100$ mA      |        |
| Reverse Input Voltage                   | $V_R$                   | 1    | 4                   |      | V     | $I_R = 100$ $\mu$ A      |        |
| Center Emission Wavelength              | $\lambda_c$             | 1270 | 1300                | 1370 | nm    |                          |        |
| Full Width Half Maximum                 | FWHM                    |      | 130                 | 185  | nm    |                          |        |
| Diode Capacitance                       | $C_T$                   |      | 16                  |      | pF    | $V_F = 0$ V, $f = 1$ MHz |        |
| Optical Power Temperature Coefficient   | $\Delta P_T / \Delta T$ |      | -0.03               |      | dB/°C | $I_F = 75 - 100$ mA DC   |        |
| Thermal Resistance                      | $\theta_{JA}$           |      | 260                 |      | °C/W  |                          | Note 3 |

Notes:

2. Typical data are at  $T_A = 25^\circ\text{C}$ .
3. Thermal resistance is measured with the transmitter coupled to a connector assembly and mounted on a printed circuit board;  $\theta_{JC} < \theta_{JA}$ .

## HFBR-1312TZ Transmitter Output Optical Power and Dynamic Characteristics

| Parameter                               | Symbol           | Min.  | Typ. <sup>[1]</sup> | Max.  | Unit | Condition      |                     | Ref.                       |
|---|------------------|-------|---------------------|-------|------|----------------|---------------------|----------------------------|
|   |                  |       |                     |       |      | T <sub>A</sub> | I <sub>F,peak</sub> |                            |
| Peak Power<br>62.5/125 μm<br>NA = 0.275 | P <sub>T62</sub> | -16.0 | -14.0               | -12.5 | dBm  | 25°C           | 75 mA               | Notes<br>2, 3, 4<br>Fig. 4 |
|   |                  | -17.5 |                     | -11.5 |      | 0-70°C         | 75 mA               |                            |
|   |                  | -15.5 | -13.5               | -12.0 |      | 25°C           | 100 mA              |                            |
|   |                  | -17.0 |                     | -11.0 |      | 0-70°C         | 100 mA              |                            |
| Peak Power<br>50/125 μm<br>NA = 0.20    | P <sub>T50</sub> | -19.5 | -17.0               | -14.5 | dBm  | 25°C           | 75 mA               | Notes<br>2, 3, 4<br>Fig. 4 |
|   |                  | -21.0 |                     | -13.5 |      | 0-70°C         | 75 mA               |                            |
|   |                  | -19.0 | -16.5               | -14.0 |      | 25°C           | 100 mA              |                            |
|   |                  | -20.5 |                     | -13.0 |      | 0-70°C         | 100 mA              |                            |
| Optical Overshoot                       | OS               |       | 5                   | 10    | %    | 0-70°C         | 75 mA               | Note 5<br>Fig. 5           |
| Rise Time                               | t <sub>r</sub>   |       | 1.8                 | 4.0   | ns   | 0-70°C         | 75 mA               | Note 6<br>Fig. 5           |
| Fall Time                               | t <sub>f</sub>   |       | 2.2                 | 4.0   | ns   | 0-70°C         | 75 mA               | Note 6<br>Fig. 5           |

Notes:

- Typical data are at T<sub>A</sub> = 25°C.
- Optical power is measured with a large area detector at the end of 1 meter of mode stripped cable, with an ST\* precision ceramic ferrule (MIL-STD-83522/13), which approximates a standard test connector. Average power measurements are made at 12.5 MHz with a 50% duty cycle drive current of 0 to I<sub>F,peak</sub>; I<sub>F,average</sub> = I<sub>F,peak</sub>/2. Peak optical power is 3 dB higher than average optical power.
- When changing from μW to dBm, the optical power is referenced to 1 mW (1000 μW).  
Optical power P(dBm) = 10\*log[P(μW)/1000μW].
- Fiber NA is measured at the end of 2 meters of mode stripped fiber using the far-field pattern. NA is defined as the sine of the half angle, determined at 5% of the peak intensity point. When using other manufacturer's fiber cable, results will vary due to differing NA values and test methods.
- Overshoot is measured as a percentage of the peak amplitude of the optical waveform to the 100% amplitude level. The 100% amplitude level is determined at the end of a 40 ns pulse, 50% duty cycle. This will ensure that ringing and other noise sources have been eliminated.
- Optical rise and fall times are measured from 10% to 90% with 62.5/125 μm fiber. LED response time with recommended test circuit (Figure 3) at 25 MHz, 50% duty cycle.

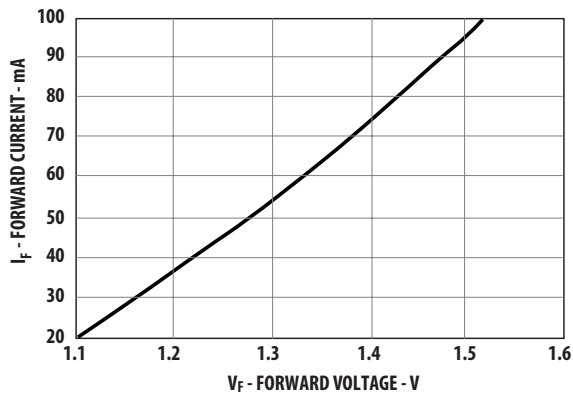

Figure 3. Typical forward voltage and current characteristics

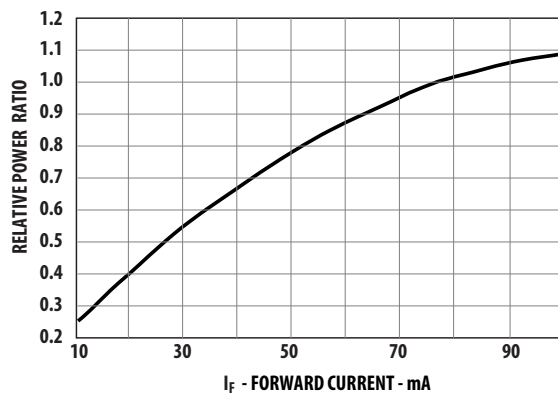

Figure 4. Normalized transmitter output power vs. forward current

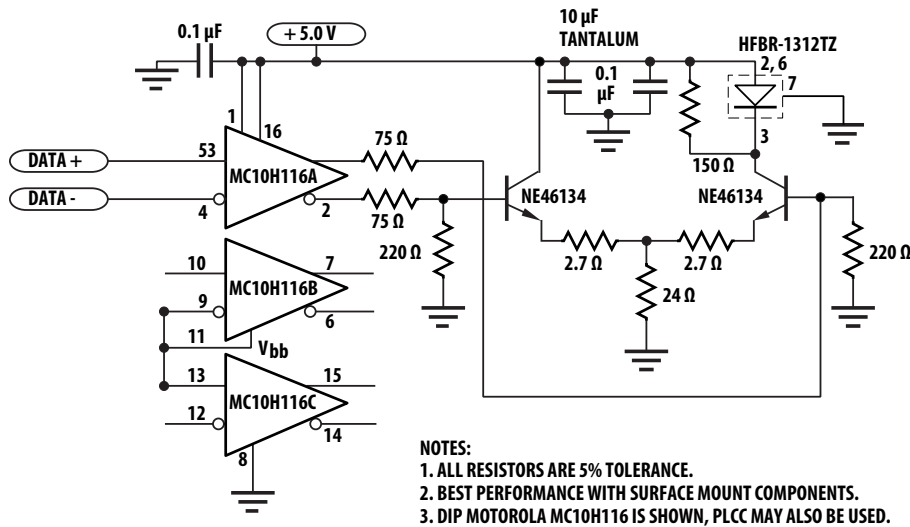

Figure 5. Recommended transmitter drive and test circuit

### HFBR-2316TZ Receiver Absolute Maximum Ratings

| Parameter                  | Symbol            | Min. | Max.     | Unit | Reference |
|----------------------------|-------------------|------|----------|------|-----------|
| Storage Temperature        | $T_s$             | -55  | 85       | °C   |           |
| Operating Temperature      | $T_A$             | -40  | +85      | °C   |           |
| Lead Soldering Temperature |                   |      | 260      | °C   | Note 1    |
| Cycle Time                 |                   |      | 10       | s    |           |
| Signal Pin Voltage         | $V_O$             | -0.5 | $V_{CC}$ | V    |           |
| Supply Voltage             | $V_{CC} - V_{EE}$ | -0.5 | 6.0      | V    | Note 2    |
| Output Current             | $I_O$             |      | 25       | mA   |           |

Notes:

- 2.0 mm from where leads enter case.
- The signal output is referred to  $V_{CC}$  and does not reject noise from the  $V_{CC}$  power supply. Consequently, the  $V_{CC}$  power supply must be filtered. The recommended power supply is +5 V on  $V_{CC}$  for typical usage with +5 V ECL logic. A -5 V power supply on  $V_{EE}$  is used for test purposes to minimize power supply noise.

**CAUTION:** The small junction sizes inherent to the design of this bipolar component increase the component's susceptibility to damage from electrostatic discharge (ESD). It is advised that normal static precautions be taken in handling and assembly of this component to prevent damage and/or degradation which may be induced by ESD.

## HFBR-2316TZ Receiver Electrical/Optical and Dynamic Characteristics

0 to 70°C;  $4.75\text{ V} < V_{CC} - V_{EE} < 5.25\text{ V}$ ; power supply must be filtered (see note 10).

| Parameter                                     | Symbol                   | Min. | Typ. <sup>(1)</sup> | Max.  | Unit              | Condition  | Ref.                 |
|---|--------------------------|------|---------------------|-------|-------------------|--|----------------------|
| Responsivity                                  | $R_p$ 62.5 $\mu\text{m}$ | 6.5  | 13                  | 19    | mV/ $\mu\text{W}$ | $\lambda_p = 1300\text{ nm}$ , 50 MHz<br>Multimode Fiber<br>62.5/125 $\mu\text{m}$ | Note 2<br>Fig. 6, 10 |
|   | $R_p$ 9 $\mu\text{m}$    | 8.5  | 17                  |       |                   | Singlemode Fiber<br>9/125 $\mu\text{m}$  |                      |
| RMS Output Noise Voltage                      | $V_{NO}$                 |      | 0.4                 | 0.59  | mV <sub>RMS</sub> | 100 MHz Bandwidth,<br>$P_R = 0\ \mu\text{W}$                                       | Note 3<br>Fig. 7     |
|   |                          |      |                     | 1.0   | mV <sub>RMS</sub> | Unfiltered Bandwidth<br>$P_R = 0\ \mu\text{W}$                                     |                      |
| Equivalent Optical<br>Noise Input Power (RMS) | $P_{N,RMS}$              |      | -45                 | -41.5 | dBm               | @ 100 MHz, $P_R = 0\ \mu\text{W}$  | Note 3               |
| Peak Input Optical Power                      | $P_R$                    |      | 0.032               | 0.071 | $\mu\text{W}$     |  |                      |
|   |                          |      |                     | -11.0 | dBm               | 50 MHz, 1 ns PWD   | Note 4<br>Fig. 8     |
|   |                          |      |                     | 80    | $\mu\text{W}$     |  |                      |
| Output Resistance                             | $R_O$                    |      | 30                  |       | Ohm               | $f = 50\text{ MHz}$  |                      |
| DC Output Voltage                             | $V_{O,DC}$               | 0.8  | 1.8                 | 2.6   | V                 | $V_{CC} = 5\text{ V}$ , $V_{EE} = 0\text{ V}$<br>$P_R = 0\ \mu\text{W}$            |                      |
| Supply Current                                | $I_{CC}$                 |      | 9                   | 15    | mA                | $R_{LOAD} = \infty$  |                      |
| Electrical Bandwidth                          | $BW_E$                   | 75   | 125                 |       | MHz               | -3 dB electrical   | Note 5               |
| Bandwidth * Rise Time Product                 |                          |      | 0.41                |       | Hz *s             |  | Note 9               |
| Electrical Rise, Fall Times,<br>10-90%        | $t_r, t_f$               |      | 3.3                 | 5.3   | ns                | $P_R = -15\text{ dBm peak}$ ,<br>@ 50 MHz  | Note 6<br>Fig. 9     |
| Pulse-Width Distortion                        | PWD                      |      | 0.4                 | 1.0   | ns                | $P_R = -11\text{ dBm, peak}$   | Note 4,7<br>Fig. 8   |
| Overshoot                                     |                          |      | 2                   |       | %                 | $P_R = -15\text{ dBm, peak}$   | Note 8               |

### Notes:

- Typical specifications are for operation at  $T_A = 25^\circ\text{C}$  and  $V_{CC} = +5\text{ V}_{DC}$ .
- The test circuit layout should be in accordance with good high frequency circuit design techniques.
- Measured with a 9-pole "brick wall" low-pass filter [Mini-Circuits™, BLP-100\*] with -3 dB bandwidth of 100 MHz.
- 11.0 dBm is the maximum peak input optical power for which pulse-width distortion is less than 1 ns.
- Electrical bandwidth is the frequency where the responsivity is -3 dB (electrical) below the responsivity measured at 50 MHz.
- The specified rise and fall times are referenced to a fast square wave optical source. Rise and fall times measured using an LED optical source with a 2.0 ns rise and fall time (such as the HFBR-1312TZ) will be approximately 0.6 ns longer than the specified rise and fall times.  
E.g.: measured  $t_{rf} \sim [(\text{specified } t_{rf})^2 + (\text{test source optical } t_{rf})^2]^{1/2}$ .
- 10 ns pulse width, 50% duty cycle, at the 50% amplitude point of the waveform.
- Percent overshoot is defined as:  $((V_{PK} - V_{100\%})/V_{100\%}) \times 100\%$ . The overshoot is typically 2% with an input optical rise time  $\leq 1.5\text{ ns}$ .
- The bandwidth\*risetime product is typically 0.41 because the HFBR-2316TZ has a second-order bandwidth limiting characteristic.
- The signal output is referred to  $V_{CC}$  and does not reject noise from the  $V_{CC}$  power supply. Consequently, the  $V_{CC}$  power supply must be filtered. The recommended power supply is +5 V on  $V_{CC}$  for typical usage with +5 V ECL logic. A -5 V power supply on  $V_{EE}$  is used for test purposes to minimize power supply noise.

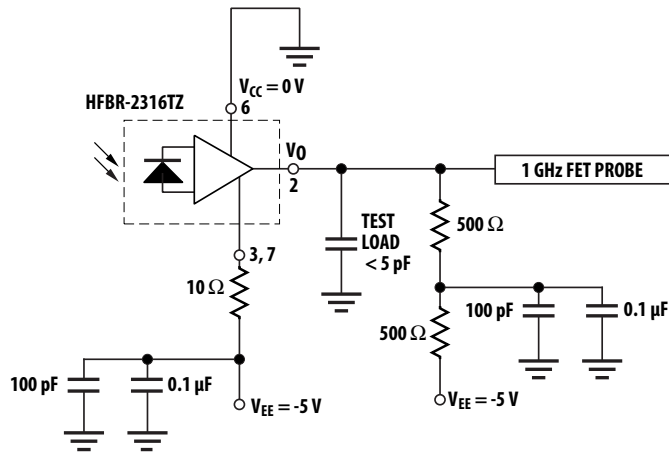

Figure 6. HFBR-2316TZ receiver test circuit

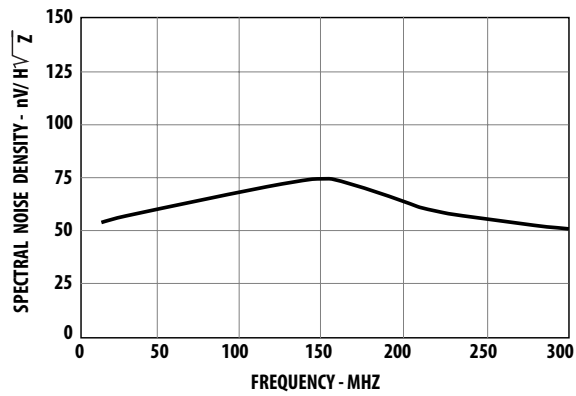

Figure 7. Typical output spectral noise density vs. frequency

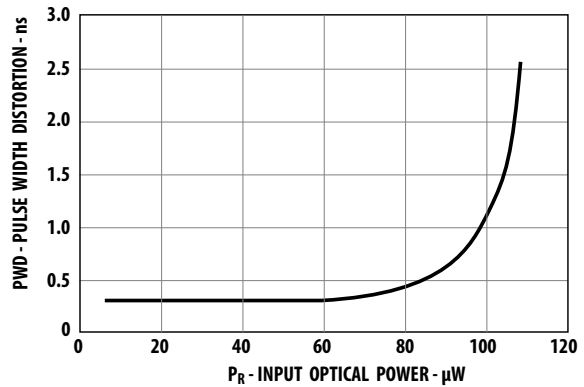

Figure 8. Typical pulse width distortion vs. peak input power.

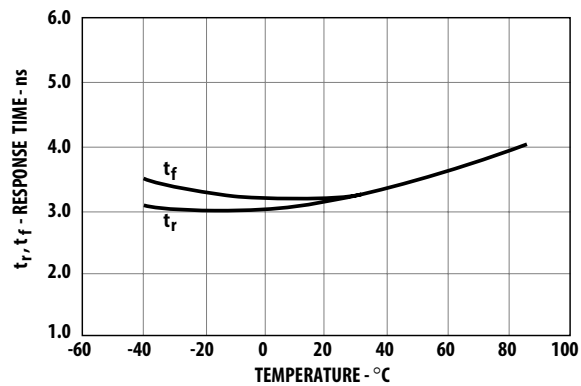

Figure 9. Typical rise and fall times vs. temperature

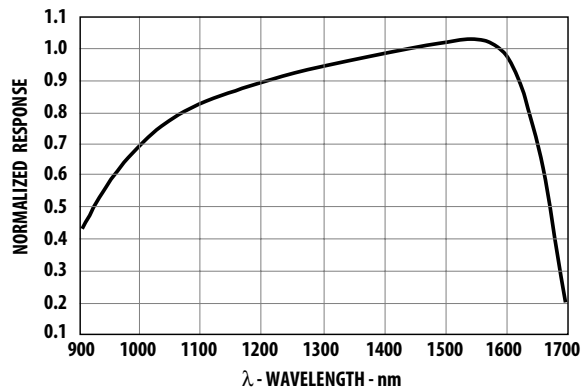

Figure 10. Normalized receiver spectral response

For product information and a complete list of distributors, please go to our web site: [www.avagotech.com](http://www.avagotech.com)

Avago, Avago Technologies, and the A logo are trademarks of Avago Technologies in the United States and other countries. Data subject to change. Copyright © 2005-2013 Avago Technologies. All rights reserved. AV02-1500EN - October 10, 2013

