

注記 NOTES

- △ 接点部までの嵌合長さ。
LENGTH TO CONTACT POINT.
- 2. 使用材料 MATERIAL
ハウジング : 46ナイロン, UL94V-0
HOUSING : 46NYLON, UL94V-0
アクチュエータ : PPS, UL94V-0
ACTUATOR : PPS, UL94V-0
ターミナル : リン青銅 (t=0.25)
TERMINAL : PHOS-BRO.(t=0.25)
メッキ : 錫ビスマスメッキ 1. 0マイクロメートル以上
PLATING : TIN-BISMUTH 1.0 MICROMETER MINIMUM
メッキ : ニッケル下地 1. 0マイクロメートル以上
PLATING : NICKEL(UNDER PLATING) 1.0 MICROMETER MINIMUM
金具 : 銅合金 (t=0.25)
FITTING NAIL : COPPER ALLOY (t=0.25)
メッキ : 錫メッキ 1. 0マイクロメートル以上
PLATING : TIN 1.0 MICROMETER MINIMUM
メッキ : ニッケル下地 1. 0マイクロメートル以上
PLATING : NICKEL(UNDER PLATING) 1.0 MICROMETER MINIMUM
- △ 3. パターンはくり止め用金具
FITTING NAIL FOR PREVENTION OF PEELING OF P.C.B.PATTERN.
- 4. エンボステープ梱包時は、アクチュエータがロックした状態とする。
WHEN CONNECTOR IS SHIPED, ACTUATOR SHOULD BE LOCKED.
- △ 5. FPC挿入深さ。
INSERTION DEPTH OF FPC
- △ 6. パターン書き込み禁止エリア。
NO FOOT PRINT AREA.
- 7. 本製品は 5 2 2 7 1 - * * 9 0 の鉛フリー品である。
THIS PRODUCT IS LEAD FREE OF 52271-**90
- △ 8. テール及び金具の平坦度は、0.15以下とする。
TAIL AND NAIL COPLANARITY TO BE 0.15 MAXIMUM.

| | | | | |
|------|------|----|------------------|---------|
| 35 | 31.2 | 29 | 52271-3079 | 30 |
| 34 | 30.2 | 28 | 52271-2979 | 29 |
| 33 | 29.2 | 27 | 52271-2879 | 28 |
| 32 | 28.2 | 26 | 52271-2779 | 27 |
| 31 | 27.2 | 25 | 52271-2679 | 26 |
| 30 | 26.2 | 24 | 52271-2579 | 25 |
| 29.0 | 25.2 | 23 | 52271-2479 | 24 |
| 28.0 | 24.2 | 22 | 52271-2379 | 23 |
| 27.0 | 23.2 | 21 | 52271-2279 | 22 |
| 26.0 | 22.2 | 20 | 52271-2179 | 21 |
| 25.0 | 21.2 | 19 | 52271-2079 | 20 |
| 24.0 | 20.2 | 18 | 52271-1979 | 19 |
| 23.0 | 19.2 | 17 | 52271-1879 | 18 |
| 22.0 | 18.2 | 16 | 52271-1779 | 17 |
| 21.0 | 17.2 | 15 | 52271-1679 | 16 |
| 20.0 | 16.2 | 14 | 52271-1579 | 15 |
| 19.0 | 15.2 | 13 | 52271-1479 | 14 |
| 18.0 | 14.2 | 12 | 52271-1379 | 13 |
| 17.0 | 13.2 | 11 | 52271-1279 | 12 |
| 16.0 | 12.2 | 10 | 52271-1179 | 11 |
| 15.0 | 11.2 | 9 | 52271-1079 | 10 |
| 14.0 | 10.2 | 8 | 52271-0979 | 9 |
| 13.0 | 9.2 | 7 | 52271-0879 | 8 |
| 12.0 | 8.2 | 6 | 52271-0779 | 7 |
| 11.0 | 7.2 | 5 | 52271-0679 | 6 |
| 10.0 | 6.2 | 4 | 52271-0579 | 5 |
| 9.00 | 5.2 | 3 | 52271-0479 | 4 |
| C | B | A | EMBOSSED PACKAGE | CKT No. |
| | | | Order No. | |

| | | | | | | |
|---|------------------------|--|--------|-----------------|----------------|--------------|
| THIS DRAWING CONTAINS INFORMATION THAT IS PROPRIETARY TO MOLEX ELECTRONIC TECHNOLOGIES, LLC AND SHOULD NOT BE USED WITHOUT WRITTEN PERMISSION | | | | | | |
| DIMENSION UNITS mm | SCALE 8:1 | CURRENT REV DESC: | | | | |
| GENERAL TOLERANCES (UNLESS SPECIFIED) | | <p style="text-align: center;">molex</p> <p>1.0 FPC CONN ZIF SMT (BOTTOM CONTACT) -LEAD FREE-</p> <p>PRODUCT CUSTOMER DRAWING</p> | | | | |
| ANGULAR TOL | ± 3.0 ° | | | | | |
| 4 PLACES | ± 0.2 | | | | | |
| 3 PLACES | ± 0.2 | | | | | |
| 2 PLACES | ± 0.2 | | | | | |
| 1 PLACE | ± 0.25 | | | | | |
| 0 PLACES | ± 0.3 | | | | | |
| DRAFT WHERE APPLICABLE MUST REMAIN WITHIN DIMENSIONS | THIRD ANGLE PROJECTION | DRAWING | SERIES | MATERIAL NUMBER | CUSTOMER | SHEET NUMBER |
| | | A3-SIZE | 52271 | SEE TABLE | GENERAL MARKET | 1 OF 2 |

NOTES

- 製品番号 52271-**-19 の梱包状態はアクチュエータがロックした状態とする。
IN THE PACKAGE, ACTUATOR OF PART NO. 52271-**-19 SHOULD BE LOCKED RE DETAILED DIMENSIONS, SEE SD-52271-036.
- 梱包数量：1000個/リール
NUMBER OF CONNECTORS：1000 PCS/REEL
- リードテープ長さ LEAD TAPE LENGTH

| | |
|---|--|
| トップテープ リーダー部 TOP TAPE LEADER PART | トップテープ 未接着部 TOP TAPE NON-BONDED PART |
| 175 ±25 | 25 ±5 |
- トップテープの剥離強度：0.1~1.3N (10~130gf) (剥離方向は下図参照)
尚、本規格値は、出荷時に適用。(但し、輸送時に剥離が発生しない事。)
PEELING OFF FORCE OF TOP TAPE：0.1~1.3N (10~130gf)
(PEELING DIRECTION AS SHOWN IN FOLLOWING FIG.)
THIS REQUIREMENT SHOULD BE APPLIED AT SHIPMENT
PEEL OFF SHOULD NOT BE ALLOWED, DURING TRANSPORTATION
- 材料 (MATERIAL)
キャリアテープ (CARRIER TAPE)：ポリプロピレン (POLYPROPYLENE)
トップテープ (TOP TAPE)：PET, PE, PEF
リール (REEL)：ポリスチレン (PS) <リサイクル材を含む>
POLYSTYRENE (PS) <RECYCLE MATERIAL CONTAINED>
- 本製品は52271-**-19の鉛フリー品である。
THIS PRODUCT IS LEAD FREE OF 52271-**-19.
- 本製品は乾燥剤入り、ハイバリア梱包仕様である。
THIS PRODUCT IS HIGH BARRIER PACKAGE WITH DESICCANT.

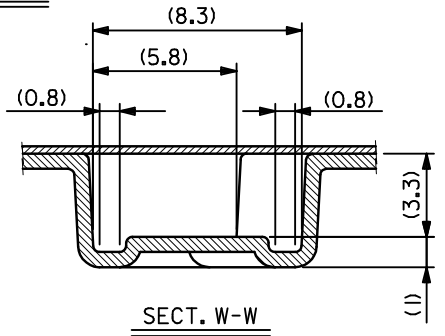
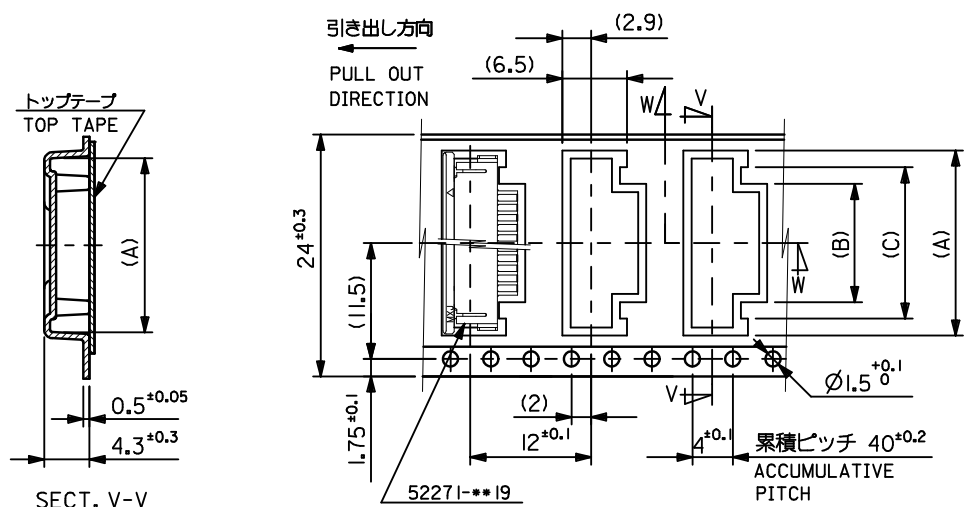
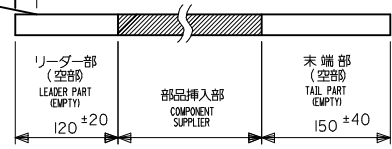
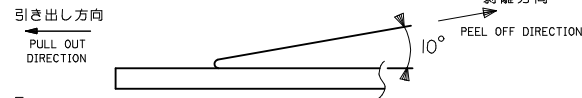
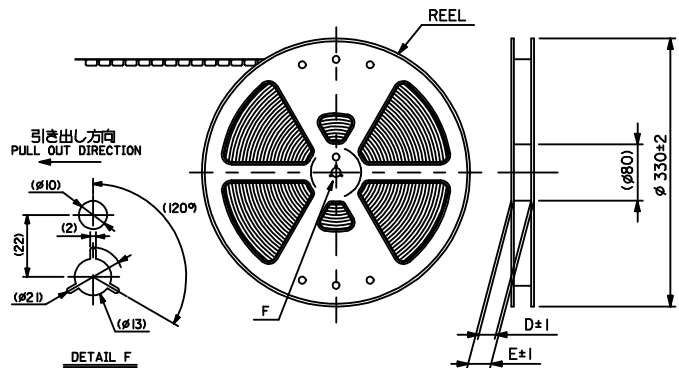

| | | | | | | | | | | | |
|-----------|-------------|--------------------|----|------|------|------------|-----|--------------|------------|------------|---|
| 24 | 29.4 | 25.4 | 15 | 11.4 | 18.3 | 52271-1179 | 11 | | | | |
| | | | 14 | 10.4 | 17.3 | -1079 | 10 | | | | |
| | | | 13 | 9.4 | 16.3 | -0979 | 9 | | | | |
| | | | 12 | 8.4 | 15.3 | -0879 | 8 | | | | |
| | | | 11 | 7.4 | 14.3 | -0779 | 7 | | | | |
| | | | 10 | 6.4 | 13.3 | -0679 | 6 | | | | |
| | | | 9 | 5.4 | 12.3 | -0579 | 5 | | | | |
| | | | 8 | 4.4 | 11.3 | 52271-0479 | 4 | | | | |
| MODEL NO. | 52271-**-19 | CARRIER TAPE WIDTH | E | D | (C) | (B) | (A) | MATERIAL NO. | 52271-0479 | 種数 CKT. | 4 |

| | | | | | | | | | | | |
|---|-------------|---------------------------------------|-------|--|--------------------|--|------------------------|------------------------|--------------|-------------------------------------|--|
| REVISED EC NO.: J2009-2061 DRWN:TKON 2009/05/20 CHKD:HMATSUMOTO 2009/05/21 APPR:NIKI ITA 2009/05/21 | DESCRIPTION | GENERAL TOLERANCES (UNLESS SPECIFIED) | | DIMENSION STYLE MM ONLY | | SCALE --- | DESIGN UNITS METRIC | THIRD ANGLE PROJECTION | | | |
| | | 10 UNDER | ±0.2 | DRAWN BY H. KAWABATA | DATE 2004/03/12 | TITLE EMBOSSED TAPE PACKAGE FOR 52271-**-19 -LEAD FREE- | | | | | |
| | | 10 OVER 30 UNDER | ±0.25 | CHECKED BY K. TOJO | DATE 2004/03/12 | MOLEX INCORPORATED | | | | | |
| | | 30 OVER | ±0.3 | APPROVED BY M. SASAO | DATE 2004/03/12 | | | | | | |
| A | REV | ANGULAR | ±3 | DRAFT WHERE APPLICABLE MUST REMAIN WITHIN DIMENSIONS | | SEE TABLE | | MATERIAL NO. | DOCUMENT NO. | SHEET NO. SD-52271-037 1 OF 3 | |

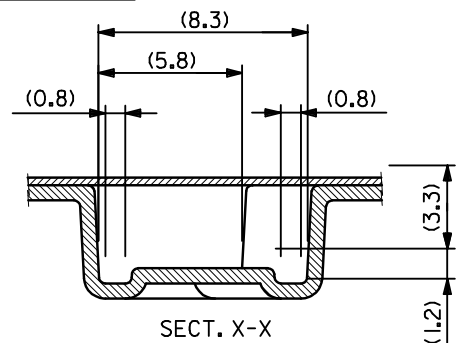
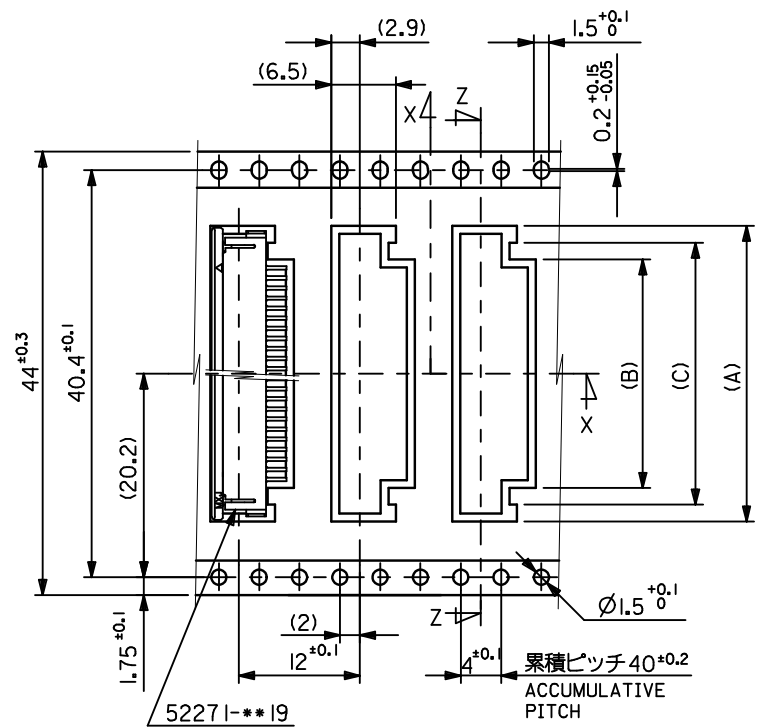
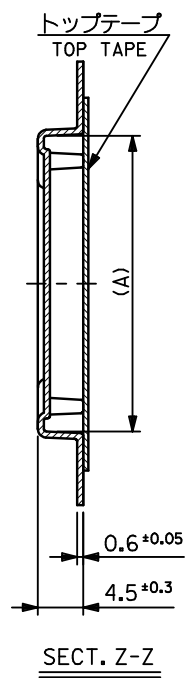
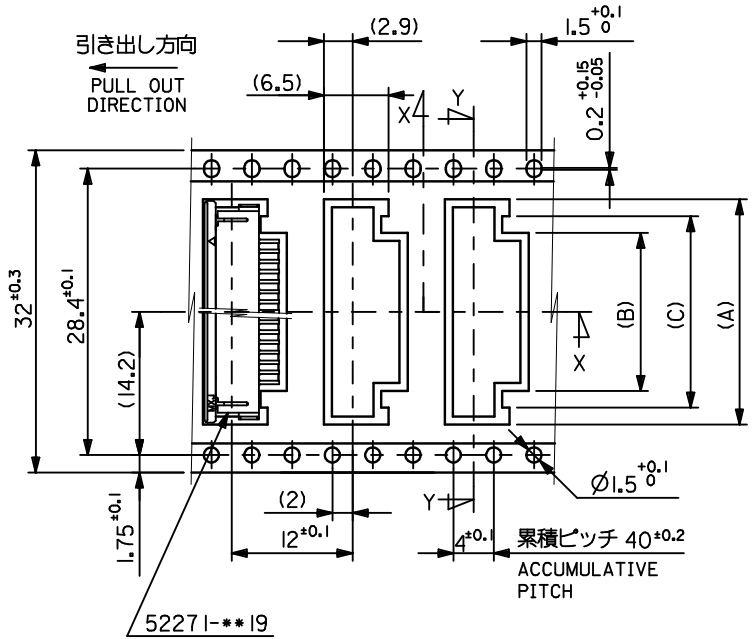
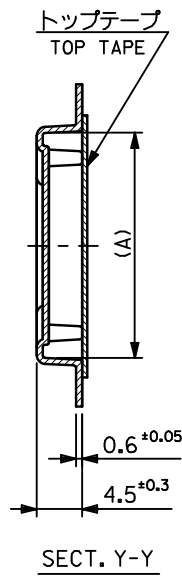

| | | | | | | | | | | |
|----|------|-------|-----|------|-------|--------------|-------------|-------|-------|----|
| 44 | 49.4 | 45.4 | 31 | 27.4 | 34.35 | 52271-2779 | 27 | | | |
| | | | 30 | 26.4 | 33.35 | -2679 | 26 | | | |
| | | | 29 | 25.4 | 32.35 | -2579 | 25 | | | |
| | | | 28 | 24.4 | 31.35 | -2479 | 24 | | | |
| | | | 27 | 23.4 | 30.35 | -2379 | 23 | | | |
| | | | 26 | 22.4 | 29.35 | -2279 | 22 | | | |
| | | | 25 | 21.4 | 28.35 | -2179 | 21 | | | |
| | | | 24 | 20.4 | 27.35 | -2079 | 20 | | | |
| | | | 23 | 19.4 | 26.35 | -1979 | 19 | | | |
| | | | 22 | 18.4 | 25.35 | -1879 | 18 | | | |
| | | | 21 | 17.4 | 24.35 | -1779 | 17 | | | |
| | | | 20 | 16.4 | 23.35 | -1679 | 16 | | | |
| | | | 32 | 37.4 | 33.4 | 19 | 15.4 | 22.35 | -1579 | 15 |
| | | | | | | 18 | 14.4 | 21.35 | -1479 | 14 |
| 17 | 13.4 | 20.35 | | | | -1379 | 13 | | | |
| 16 | 12.4 | 19.35 | | | | 52271-1279 | 12 | | | |
| | | | (C) | (B) | (A) | MATERIAL NO. | 標 記 CKT. | | | |

| | | | | | | |
|--|--|---|--------------------|--|------------------------|------------------------------|
| REVISED EC NO.: J2009-2061 DRWN:TKON 2009/05/20 CHKD:HATSUMOTO 2009/05/21 APPR:NIKI ITA 2009/05/21 REV: A | DESCRIPTION GENERAL TOLERANCES (UNLESS SPECIFIED) 10 UNDER ±0.2 10 OVER 30 UNDER ±0.25 30 OVER ±0.3 ANGULAR ±3° DRAFT WHERE APPLICABLE MUST REMAIN WITHIN DIMENSIONS | DIMENSION STYLE MM ONLY | SCALE --- | DESIGN UNITS METRIC | THIRD ANGLE PROJECTION | |
| | | DRAWN BY H. KAWABATA | DATE 2004/03/12 | TITLE EMBOSSED TAPE PACKAGE FOR 52271-**-19 -LEAD FREE- | | |
| | | CHECKED BY K. TOJO | DATE 2004/03/12 | MOLEX INCORPORATED | | |
| | | APPROVED BY M. SASAO | DATE 2004/03/12 | MATERIAL NO. SEE TABLE | | DOCUMENT NO. SD-52271-037 |
| SIZE A3 | | THIS DRAWING CONTAINS INFORMATION THAT IS PROPRIETARY TO MOLEX INCORPORATED AND SHOULD NOT BE USED WITHOUT WRITTEN PERMISSION | | | | |

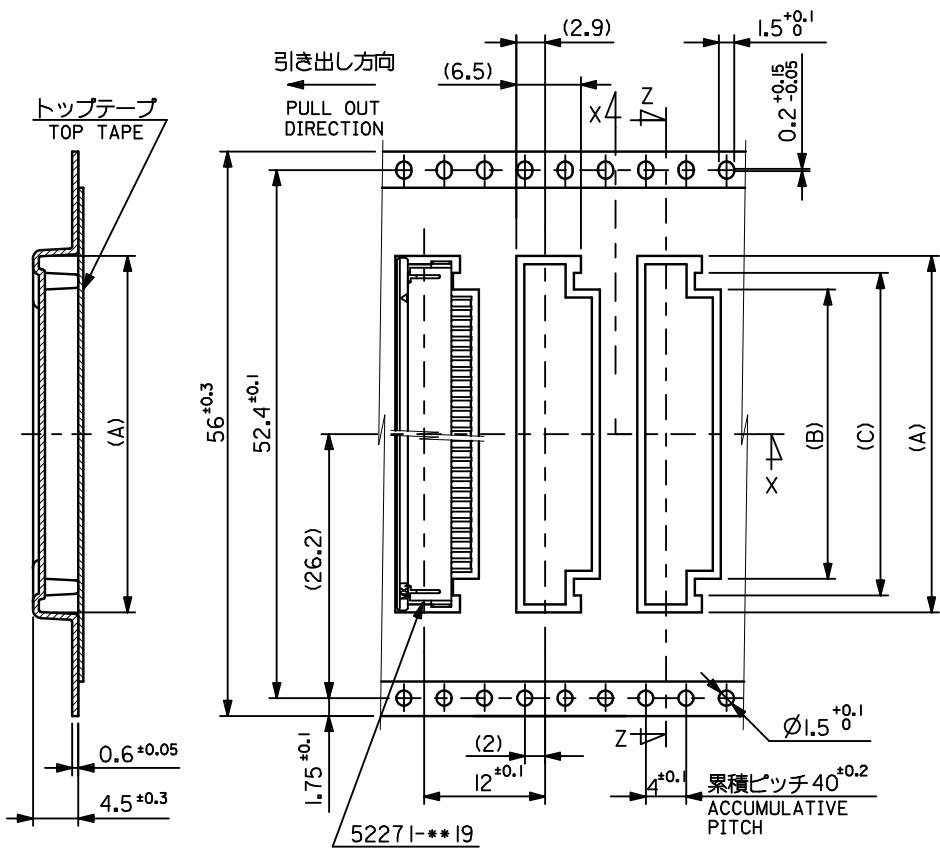

SECT. Z-Z

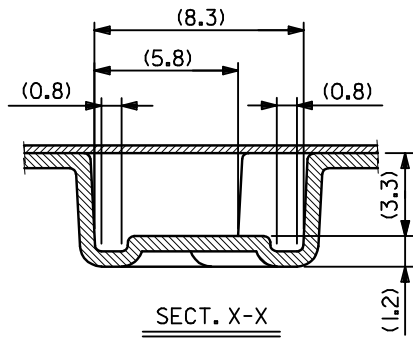

SECT. X-X

| | | | | | | | |
|--------------------------------|------|------|-----|------|-------|--------------|-------------|
| 56 | 61.4 | 57.4 | 34 | 30.4 | 37.35 | 52271-3079 | 30 |
| | | | 33 | 29.4 | 36.35 | 52271-2979 | 29 |
| | | | 32 | 28.4 | 35.35 | 52271-2879 | 28 |
| キャリアテープ幅 CARRIER TAPE WIDTH | E | D | (C) | (B) | (A) | MATERIAL NO. | 種 数 CKT. |

| | | | | | | | | |
|--|--|-----------|----------------------------|--|---|------------------------|---------------------------|--|
| REVISED EC NO.: J2009-2061 2009/05/20 DRWN:TKON CHKD:HMATSUMOTO 2009/05/21 APPR:NUKITA 2009/05/21 | GENERAL TOLERANCES (UNLESS SPECIFIED) | | DIMENSION STYLE MM ONLY | | SCALE --- | DESIGN UNITS METRIC | THIRD ANGLE PROJECTION | |
| | 10 UNDER | ±0.2 | DRAWN BY H.KAWABATA | DATE 2004/03/12 | TITLE EMBOSSSED TAPE PAKEGE FOR 52271-**-19 -LEAD FREE- | | | |
| | 10 OVER 30 UNDER | ±0.25 | CHECKED BY K.TOJO | DATE 2004/03/12 | MOLEX INCORPORATED DOCUMENT NO. SD-52271-037 SHEET NO. 3 OF 3 | | | |
| | 30 OVER | ±0.3 | APPROVED BY M.SASAO | DATE 2004/03/12 | | | | |
| ANGULAR DRAFT WHERE APPLICABLE MUST REMAIN WITHIN DIMENSIONS | ±3 | SEE TABLE | | THIS DRAWING CONTAINS INFORMATION THAT IS PROPRIETARY TO MOLEX INCORPORATED AND SHOULD NOT BE USED WITHOUT WRITTEN PERMISSION | | | | |