

DISK # K6 DWG SIZE C DATA CONTAINED IN THIS DOCUMENT IS PROPRIETARY TO TROMPETER ELECTRONICS INC. AND SHALL NOT BE DISCLOSED, COPIED OR USED FOR PROCUREMENT OR MANUFACTURE WITHOUT EXPRESS WRITTEN PERMISSION.

REV		EO	DESCRIPTION	DWN	APPROVED	DATE
M	9322		-7, -23, -24A, -25A, -26, -32, -33, -42, -43, -56, -57, -60, -64; ASSEMBLE PER BLOCK WAS TAI-104; AND GENERAL UPDATE	DKC	B.M.; <i>[Signature]</i>	6/8/91

DASH NO	CABLES ACCOMMODATED	A DIM	B DIM	C FLATS	D FLATS	E DIA	ASSEMBLE PER
-7	TRC-50-2 TRC-75-2	1.135	.096	.438	.438	.500	TAI-189
-8	8227, BELDEN	1.716	.130	.625	.688	.750	TAI-103
-9	TWC-78-2 TWC-124-2	1.135	.096	.438	.438	.500	TAI-102
-A9	BL782, TIMES BL982, TIMES BL1242, TIMES						
-10	RG-22 754E, AT&T						
-11	760A, AT&T						
-12	16 PEVL, AT&T V1-AL, GENERAL	1.716	.130	.625	.688	.750	TAI-128
-13	TRF-59, TIMES						TAI-129
-13A	8232, BELDEN						TAI-165
-14	8233, BELDEN						TAI-129
-23	250-3884, MICRODOT						TAI-189
-24	202-3934, MICRODOT						TAI-102
-24A	9530A5117, RAYCHEM						TAI-189
-25	T-43M, GENERAL						TAI-102
-25A	5021H5331, RAYCHEM						
-26	7028A5518, RAYCHEM						TAI-189
-27	T19TPSJ2619EN, WOVEN 202-3927, MICRODOT 202-3942, MICRODOT	1.135	.096	.438	.438	.500	TAI-102
-29	TWC-78-1/TWC-124-1A						
-30	761A, AT&T 8441, BELDEN						
-32	TRC-50-1						
-33	TRC-75-1						
-42	21-204, ESSEX 4463, CONSOLIDATED						TAI-189
-43	250-4044/250-4045 293-3930, MICRODOT						
-45	M275000-22TE2T14 1100-66F, STANDARD						TAI-102
-46	9860, BELDEN	1.716	.130	.625	.688	.750	TAI-103
-47	M17/176-00002	1.135	.096	.438	.438	.500	TAI-102
-49	TWAC-78-1F2	1.716	.130	.625	.688	.750	TAI-103
-54	89207, BELDEN	1.716	.130	.625	.688	.750	TAI-103
-55	89272, BELDEN						TAI-102
-56	6C8756C1, GRUMMAN						TAI-189
-57	6C8756B1, GRUMMAN						TAI-102
-58	6C875TM24H, GRUMMAN	1.135	.096	.438	.438	.500	TAI-189
-59	6C875LN1, GRUMMAN						
-60	M17/177, THERMATICS 380-10045, BOEING						
-64	7528A5314, RAYCHEM						

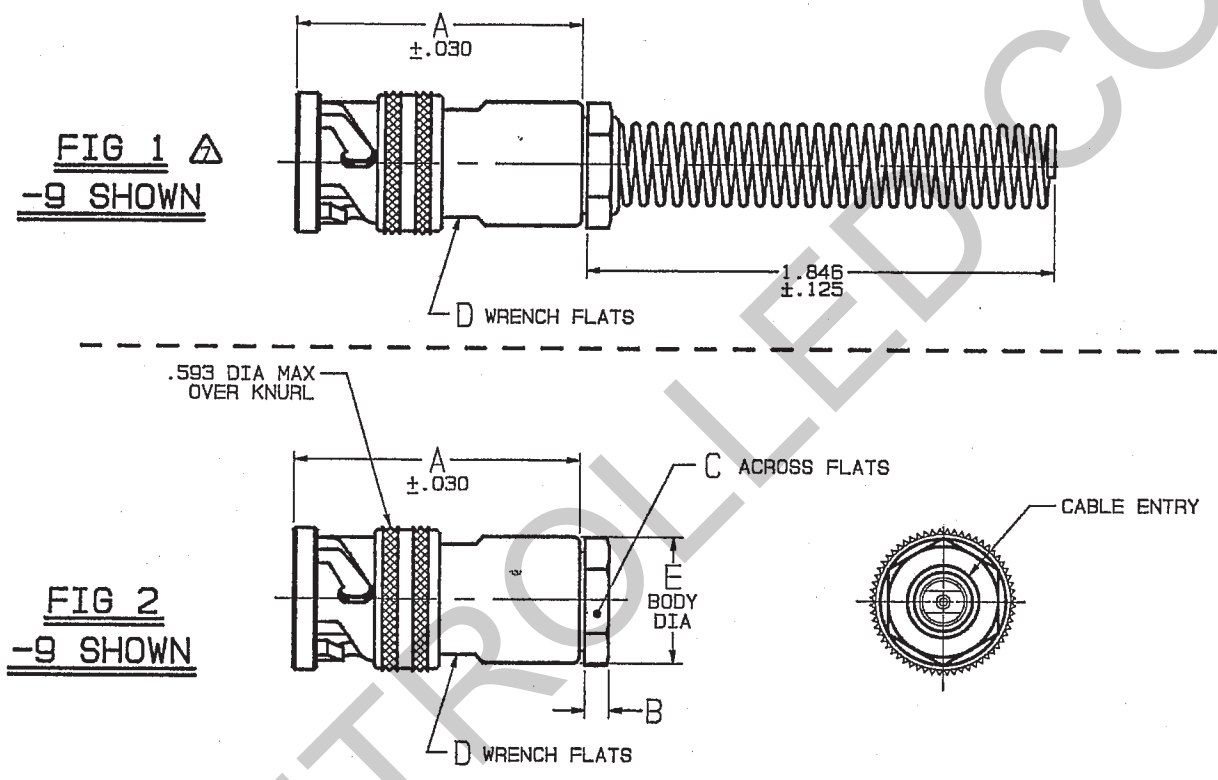

INCH	MM	INCH	MM
.005	0.13	.345	8.76
.030	0.76	.347	8.81
.096	2.44	.352	8.94
.125	3.18	.362	9.19
.130	3.30	.438	11.13
.132	3.35	.455	11.56
.145	3.68	.475	12.07
.164	4.17	.485	12.32
.183	4.65	.490	12.45
.191	4.85	.500	12.70
.198	5.03	.593	15.06
.200	5.08	.625	15.88
.217	5.51	.688	17.48
.235	5.97	.750	19.05
.274	6.96	1.135	28.83
.285	7.24	1.716	43.59
.300	7.62	1.846	46.89
.323	8.20		

DASH NO	ENTRY DIA	DASH NO	ENTRY DIA
-7	.274	-30	.235
-8	.345	-32	.191
-9	.285	-33	.217
-A9	.285	-42	.300
-10	.455	-43	.200
-11	.347	-45	.183
-12	.485	-46	.475
-13	.362	-47	.164
-13A	.352	-49	.132
-14	.490	-54	.323
-23	.183	-55	.250
-24	.191	-56	.191
-24A	.200	-57	.191
-25	.285	-58	.198
-25A	.285	-59	.198
-26	.183	-60	.217
-27	.145	-64	.183
-29	.191		

MODEL NO	DASH NO/CABLE GROUP																
PL75FL (TWINAX)	-8	-9	-A9	-10	-11	-12	-24	-25	-27	-29	-30	-45	-46	-47	-49	-54	-55
PL75FL (TRIAx)	-7	-13	-13A	-14	-23	-24A	-25A	-26	-32	-33	-42	-43	-56	-57	-59	-60	-64
PL75FL (QUADRAX)	-58																

6. EXAMPLE OF COMPLETE MODEL NO:
 PL75FL - 47 
 BASIC MODEL NO ——— DASH NO

5. EXAMPLE OF COMPLETE PART NO:
 310-0006 - 47 
 BASIC PART NO ——— DASH NO

RED INDICATES ORIGINAL

-  CLAMP NUT OMITTED
-  IF BEND RELIEF SPRING REQD (SEE FIG 1)
 ADD SUFFIX "BR" TO MODEL NO (NOT AVAILABLE
 WITH CABLE GROUPS -8, -10, -11, -12, -13,
 -13A, -14, -46 & -54)
- 3. CONCENTRIC TWINAX/TRIAx 4-LUG TRB CABLE PLUG
- 2. FINISH: TFS-1A (NICKEL)
- 1. ALL DIM ARE IN INCHES

QTY	DESCRIPTION	PART NUMBER	ITEM
TOL UNLESS SPECIFIED .XX ± .XXX ± .005 .XXXX ± ANGLE ±	TROMPETER RF connectivity	PL75FL/PL75FLBR	
DWN DKC 5-23-91	MATERIAL CODE IDENT	DRAWING NO.	REV
CHK B.M. 5-24-91	14949	310-0006	M
ENGR			
NEXT ASSY APPR <i>[Signature]</i> 6-3-91	SCALE 2/1	DATE 3/21/83	SHEET 1 OF 2