

Mini overload relays

Bimetallic style



CGT-12M

Description

- Direct mount on the mini contactors with screw clamp connection.
contactor types : CGMS-6A(D), CGMS-9A(D),
CGMS-12A(D), CGMS-16A(D)
- DIN rail or screw mountable with the optional base AZ-12H
- Small physical size : 44 mm wide
- 1NO+1NC trip contacts
- Trip class 10A according to IEC60947-4-1
- Differential current/Phase failure protection : CGT types
- Non-differential CGTH types are available for the economic solution
- Ambient compensated -5 to 40 °C
- Manual/Automatic reset convertible.
- Remote reset is optional
- Trip free designed

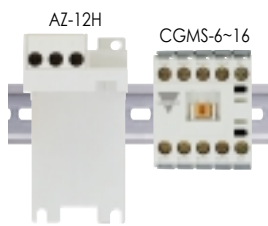

Separate mount
Direct mount



CGT-12M

Catalog No.

Setting ranges(A)	Differential type	Non-differential type	
	3-heater	3-heater	2-heater
0.1 - 0.16	CGT-12M • 0.16	CGTH-12MH/3 • 0.16	CGTH-12MH • 0.16
0.16 - 0.25	CGT-12M • 0.25	CGTH-12MH/3 • 0.25	CGTH-12MH • 0.25
0.25 - 0.4	CGT-12M • 0.4	CGTH-12MH/3 • 0.4	CGTH-12MH • 0.4
0.4 - 0.63	CGT-12M • 0.63	CGTH-12MH/3 • 0.63	CGTH-12MH • 0.63
0.63 - 1	CGT-12M • 1	CGTH-12MH/3 • 1	CGTH-12MH • 1
1 - 1.6	CGT-12M • 1.6	CGTH-12MH/3 • 1.6	CGTH-12MH • 1.6
1.6 - 2.5	CGT-12M • 2.5	CGTH-12MH/3 • 2.5	CGTH-12MH • 2.5
2.5 - 4	CGT-12M • 4	CGTH-12MH/3 • 4	CGTH-12MH • 4
4 - 6	CGT-12M • 6	CGTH-12MH/3 • 6	CGTH-12MH • 6
5 - 8	CGT-12M • 8	CGTH-12MH/3 • 8	CGTH-12MH • 8
6 - 9	CGT-12M • 9	CGTH-12MH/3 • 9	CGTH-12MH • 9
7 - 10	CGT-12M • 10	CGTH-12MH/3 • 10	CGTH-12MH • 10
9 - 13	CGT-12M • 13	CGTH-12MH/3 • 13	CGTH-12MH • 13
12 - 16	CGT-12M • 16	CGTH-12MH/3 • 16	CGTH-12MH • 16

Auxiliary (Trip) contact rating

AC15(11) duty			DC13(11) duty	
110V	220V	550V	110V	220V
2.5(0.3)A	2(0.3)A	1(0.3)A	0.28A	0.14A

Note) Values of () are the ratings of NO contact under auto reset mode.

For more information

- Drawings → page 37
- Mini Contactors → page 18~26
- Starters → page 32
- Separate mounting unit → page 33
- Operating curves → page 39



CGT(H)-12M

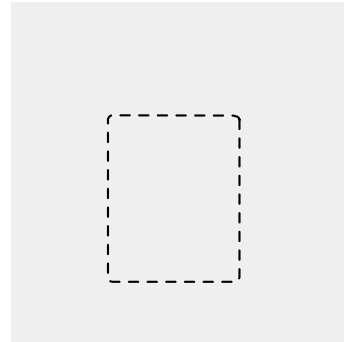
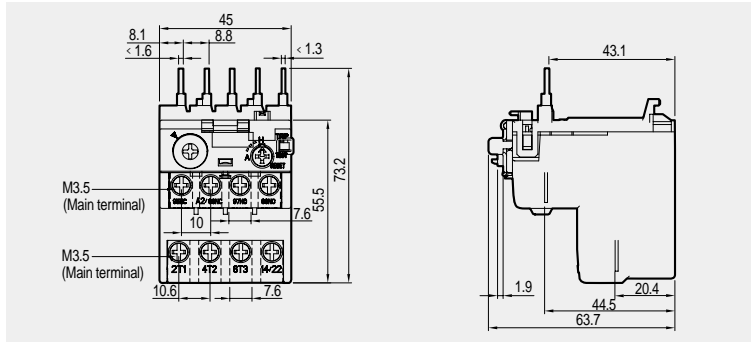

0.1kg

CGT(H)-12MH

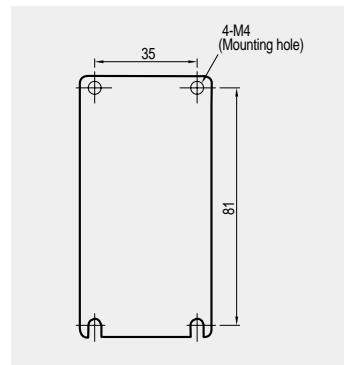
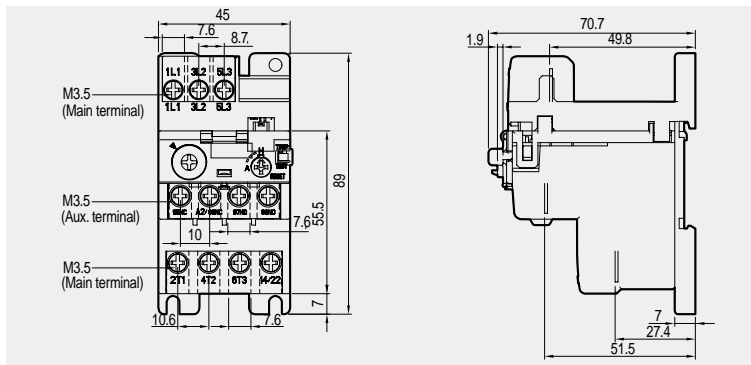

0.4kg

**CGMSS-6,9,
12,16A**

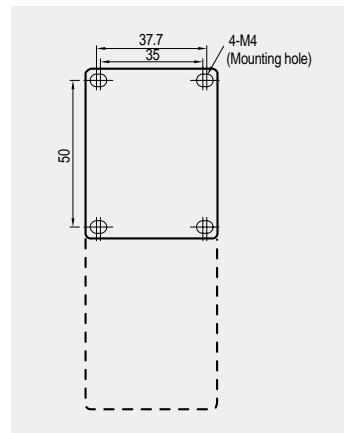
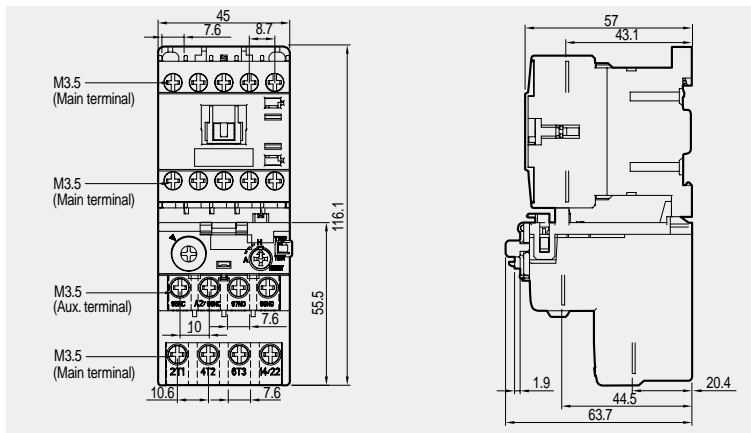

0.26kg

**CGMSS-6,9,
12,16D**

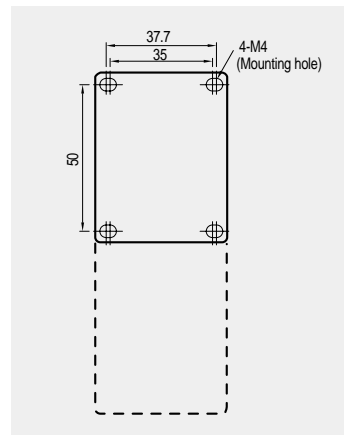
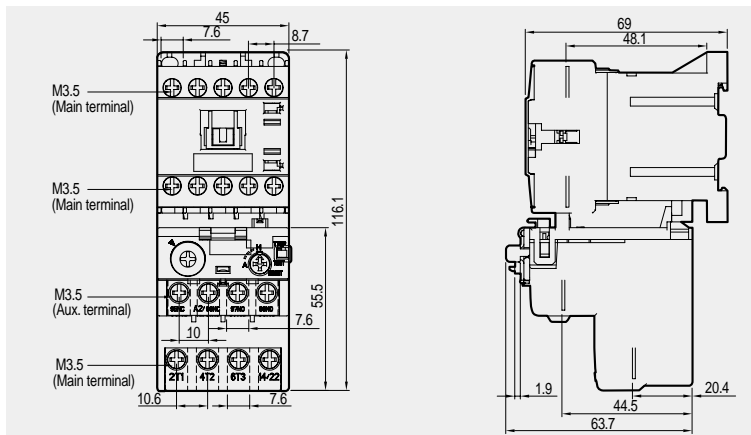

0.39kg

Overload relay curves

Non-Differential type

CGTH-12M

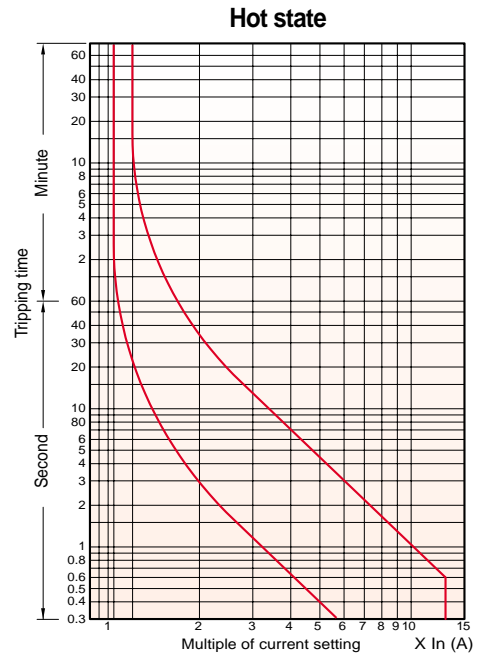
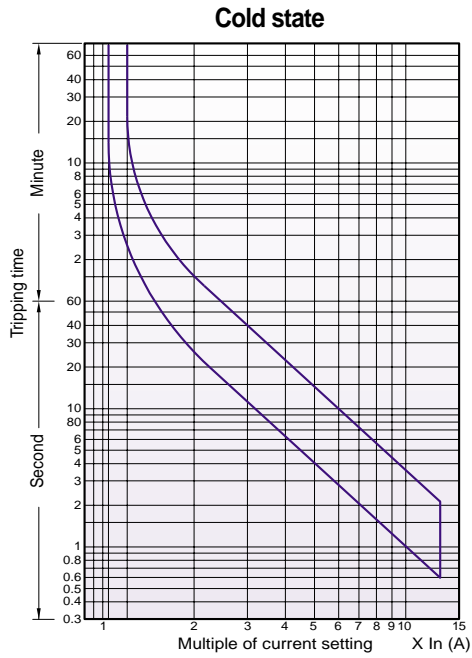

Differential type

CGT-12M

