

NOTES:

1. PCB THICKNESS BETWEEN 1.4 TO 2.6MM
2. ELECTRICAL PERFORMANCE ACCORDING TO CAT 5
3. MATERIAL COMPLIANT TO ROHS DIRECTIVE 2002/95/EC

PCB FOOTPRINT FOR CAT 5  
VIEW FROM COMPONENT SIDE

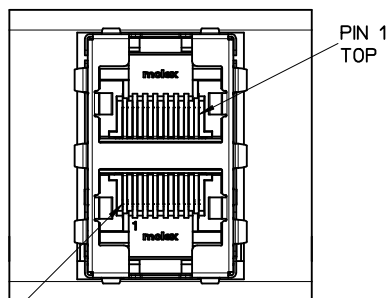
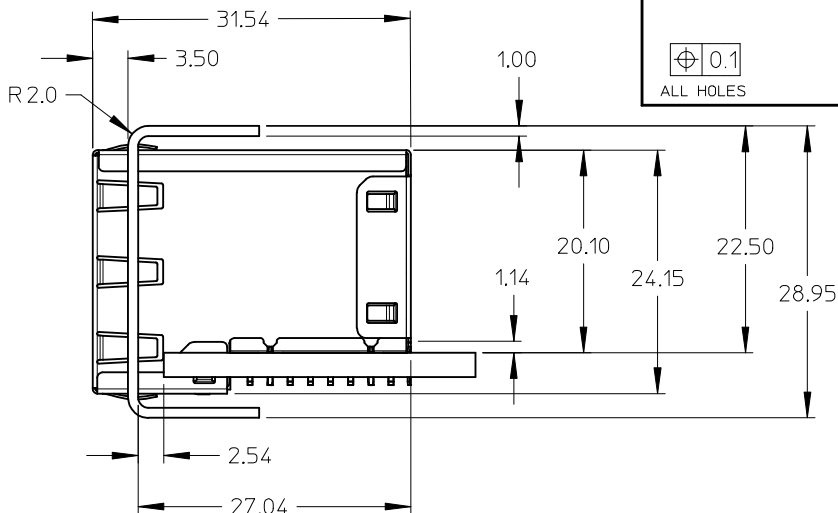
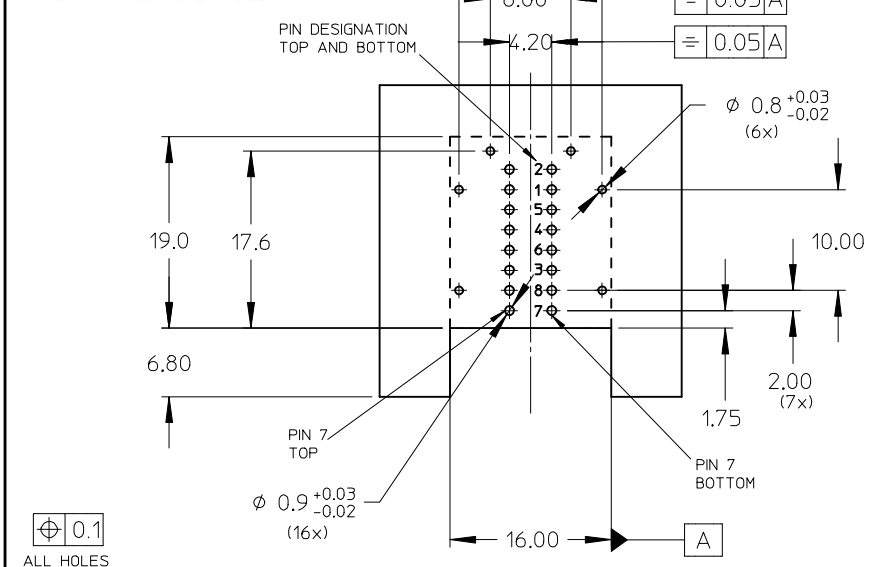

FRONT PANEL CUT OUT

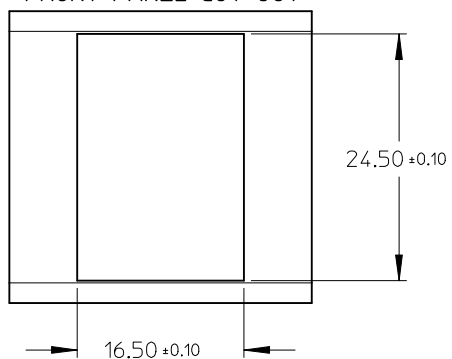

SCALE 1:1

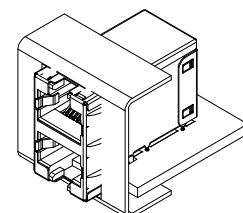

<b>COSMETIC UPDATE</b> EC NO: MG2007-0112 2007/05/02 DRWN:FCARABET 2007/05/03 CHKD:WFUNK 2007/05/03 APPR:TREMHOFF 2007/05/09	QUALITY SYMBOLS ▽=0 ◻=0	GENERAL TOLERANCES (UNLESS SPECIFIED) <table border="1"> <tr> <td></td> <td>mm</td> <td>INCH</td> </tr> <tr> <td>4 PLACES</td> <td>± ---</td> <td>± ---</td> </tr> <tr> <td>3 PLACES</td> <td>± ---</td> <td>± ---</td> </tr> <tr> <td>2 PLACES</td> <td>± ---</td> <td>± ---</td> </tr> <tr> <td>1 PLACE</td> <td>± ---</td> <td>± ---</td> </tr> </table>		mm	INCH	4 PLACES	± ---	± ---	3 PLACES	± ---	± ---	2 PLACES	± ---	± ---	1 PLACE	± ---	± ---	DIMENSION STYLE <b>MM ONLY</b>	SCALE <b>2:1</b>	DESIGN UNITS <b>METRIC</b>	THIRD ANGLE PROJECTION
		mm	INCH																		
	4 PLACES	± ---	± ---																		
	3 PLACES	± ---	± ---																		
2 PLACES	± ---	± ---																			
1 PLACE	± ---	± ---																			
DRAWN BY FCARABETTA	DATE 2006/10/18	TITLE <b>ATCA 2X1 RJ45 JACK CAT 5</b>																			
CHECKED BY WFUNK	DATE 2006/10/18	APPROVED BY TREMHOF																			
MATERIAL NO. <b>85067-0003</b>	DATE 2006/10/18	MOLEX INCORPORATED	DOCUMENT NO. <b>SD-85067-003</b>	SHEET NO. <b>1 OF 1</b>																	

DRAFT WHERE APPLICABLE  
MUST REMAIN  
WITHIN DIMENSIONS

THIS DRAWING CONTAINS INFORMATION THAT IS PROPRIETARY TO MOLEX INCORPORATED AND SHOULD NOT BE USED WITHOUT WRITTEN PERMISSION