

AT25QF641



64-Mbit, 2.7 V Minimum

SPI Serial Flash Memory with Dual I/O, Quad I/O, and QPI Support

**NOT RECOMMENDED
FOR NEW DESIGNS.
Use AT25QF641B.**

Features

- Single 2.7 V - 3.6 V Supply
- Serial Peripheral Interface (SPI) and Quad Peripheral Interface (QPI) Compatible
 - Supports SPI Modes 0 and 3
 - Supports Dual Output Read and Quad I/O Program and Read
 - Supports QPI Program and Read
 - 104 MHz Maximum Operating Frequency
 - Clock-to-Output (t_{V1}) of 6 ns
 - Up to 52 MB/s continuous data transfer rate
- Quad SPI Enabled (factory default setting, see Section 6.7)
- Full Chip Erase
- Flexible, Optimized Erase Architecture for Code and Data Storage Applications
 - 0.6 ms Typical Page Program (256 Bytes) Time
 - 60 ms Typical 4-Kbyte Block Erase Time
 - 350 ms Typical 32-Kbyte Block Erase Time
 - 700 ms Typical 64-Kbyte Block Erase Time
- Hardware Controlled Locking of Protected Blocks via \overline{WP} Pin
- 4 kbit secured One-Time Programmable Security Register
- Software and Hardware Write Protection
- Serial Flash Discoverable Parameters (SFDP) Register
- Flexible Programming
 - Byte/Page Program (1 to 256 Bytes)
 - Dual or Quad Input Byte/Page Program (1 to 256 Bytes)
- Erase/Program Suspend and Resume
- JEDEC Standard Manufacturer and Device ID Read Methodology
- Low Power Dissipation
 - 2 μ A Deep Power-Down Current (Typical)
 - 10 μ A Standby current (Typical)
- Endurance: 100,000 program/erase cycles (4 kB, 32 kB or 64 kB blocks)
- Data Retention: 20 Years
- Industrial Temperature Range: -40°C to +85°C
- Industry Standard Green (Pb/Halide-free/RoHS Compliant) Package Options
 - 8-lead SOIC (208-mil)
 - Die in Wafer Form

1. Introduction

The AT25QF641 is a serial interface Flash memory device designed for use in a wide variety of high-volume consumer based applications in which program code is shadowed from Flash memory into embedded or external RAM for execution. The flexible erase architecture of the AT25QF641 is ideal for data storage as well, eliminating the need for additional data storage devices.

The erase block sizes of the AT25QF641 have been optimized to meet the needs of today's code and data storage applications. By optimizing the size of the erase blocks, the memory space can be used much more efficiently. Because certain code modules and data storage segments must reside by themselves in their own erase regions, the wasted and unused memory space that occurs with large block erase Flash memory devices can be greatly reduced. This increased memory space efficiency allows additional code routines and data storage segments to be added while still maintaining the same overall device density.

SPI clock frequencies of up to 104 MHz are supported allowing equivalent clock rates of 208 MHz for Dual Output and 416 MHz for Quad Output when using the QPI and Fast Read Dual/Quad I/O instructions. The AT25QF641 array is organized into 65,536 programmable pages of 256-bytes each. Up to 256 bytes can be programmed at a time using the Page Program instructions. Pages can be erased 4 KB Block, 32 KB Block, 64 KB Block or the entire chip.

The devices operate on a single 2.7 V to 3.6 V power supply with current consumption as low as 5 mA active and 2 μ A for Deep Power Down. All devices are offered in space-saving packages. The device supports JEDEC standard manufacturer and device identification with a 4 Kbit Secure OTP.

2. Pinouts and Pin Descriptions

The following figure shows the available package types.

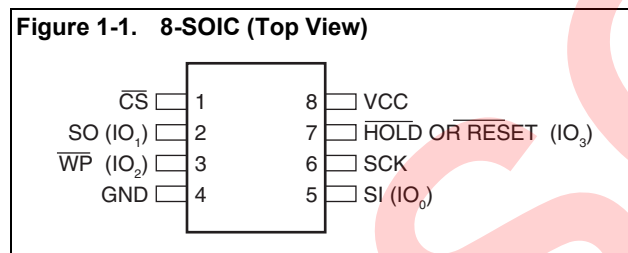

During all operations, V_{CC} must be held stable and within the specified valid range: V_{CC} (min) to V_{CC} (max).

All of the input and output signals must be held high or low (according to voltages of V_{IH} , V_{OH} , V_{IL} or V_{OL}).

Table 1-1. Pin Descriptions

Symbol	Name and Function	Asserted State	Type
$\overline{\text{CS}}$	<p>CHIP SELECT</p> <p>When this input signal is high, the device is deselected and serial data output pins are at high impedance. Unless an internal program, erase or write status register cycle is in progress, the device will be in the standby power mode (this is not the deep power down mode). Driving Chip Select ($\overline{\text{CS}}$) low enables the device, placing it in the active power mode. After power-up, a falling edge on Chip Select ($\overline{\text{CS}}$) is required prior to the start of any instruction.</p>	Low	Input
SCK	<p>SERIAL CLOCK</p> <p>This input signal provides the timing for the serial interface. Instructions, addresses, or data present at serial data input are latched on the rising edge of Serial Clock (SCK). Data are shifted out on the falling edge of the Serial Clock (SCK).</p>	-	Input
SI (I/O ₀)	<p>SERIAL INPUT</p> <p>The SI pin is used to shift data into the device. The SI pin is used for all data input including command and address sequences. Data on the SI pin is always latched in on the rising edge of SCK.</p> <p>With the Dual-Output and Quad-Output Read commands, the SI Pin becomes an output pin (I/O₀) in conjunction with other pins to allow two or four bits of data on (I/O₃₋₀) to be clocked in on every falling edge of SCK</p> <p>To maintain consistency with the SPI nomenclature, the SI (I/O₀) pin is referenced as the SI pin unless specifically addressing the Dual-I/O and Quad-I/O modes in which case it is referenced as I/O₀.</p> <p>Data present on the SI pin is ignored whenever the device is deselected ($\overline{\text{CS}}$ is deasserted).</p>	-	Input/Output
SO (I/O ₁)	<p>SERIAL OUTPUT</p> <p>The SO pin is used to shift data out from the device. Data on the SO pin is always clocked out on the falling edge of SCK.</p> <p>With the Dual-Output Read commands, the SO Pin remains an output pin (I/O₀) in conjunction with other pins to allow two bits of data on (I/O₁₋₀) to be clocked in on every falling edge of SCK</p> <p>To maintain consistency with the SPI nomenclature, the SO (I/O₁) pin is referenced as the SO pin unless specifically addressing the Dual-I/O modes in which case it is referenced as I/O₁. The SO pin is in a high-impedance state whenever the device is deselected ($\overline{\text{CS}}$ is deasserted).</p>	-	Input/Output
$\overline{\text{WP}}$ (I/O ₂)	<p>WRITE PROTECT</p> <p>The Write Protect ($\overline{\text{WP}}$) pin can be used to protect the Status Register against data modification. Used in company with the Status Register's Block Protect (SEC, TB, BP2, BP1 and BP0) bits and Status Register Protect SRP bits, a portion or the entire memory array can be hardware protected. The $\overline{\text{WP}}$ pin is active low. The $\overline{\text{WP}}$ pin (Hardware Write Protect) function is not available since the QE bit Status register is set to Quad I/O by factory default.</p>	-	Input/Output

Table 1-1. Pin Descriptions (Continued)

Symbol	Name and Function	Asserted State	Type
$\overline{\text{HOLD}}$ (I/O ₃)	<p>HOLD</p> <p>The $\overline{\text{HOLD}}$ pin is used to pause a serial sequence of the SPI flash memory without resetting the clocking sequence. To enable the HOLD mode, the $\overline{\text{CS}}$ must be in low state. The HOLD mode effects on with the falling edge of the HOLD signal with CLK being low. The HOLD mode ends on the rising edge of HOLD signal with SCK being low.</p> <p>In other words, $\overline{\text{HOLD}}$ mode can't be entered unless SCK is low at the falling edge of the $\overline{\text{HOLD}}$ signal. And HOLD mode can't be exited unless SCK is low at the rising edge of the $\overline{\text{HOLD}}$ signal.</p> <p>If $\overline{\text{CS}}$ is driven high during a $\overline{\text{HOLD}}$ condition, it resets the internal logic of the device. As long as HOLD signal is low, the memory remains in the HOLD condition. To re-work communication with the device, $\overline{\text{HOLD}}$ must go high, and $\overline{\text{CS}}$ must go low.</p>	-	Input/Output
V _{CC}	<p>DEVICE POWER SUPPLY</p> <p>V_{CC} is the supply voltage. It is the single voltage used for all device functions including read, program, and erase. The V_{CC} pin is used to supply the source voltage to the device. Operations at invalid V_{CC} voltages may produce spurious results and should not be attempted.</p>	-	Power
GND	<p>GROUND</p> <p>V_{SS} is the reference for the V_{CC} supply voltage. The ground reference for the power supply. GND should be connected to the system ground.</p>	-	Power

2. Block Diagram

Figure 2-1 shows a block diagram of the AT25QF641 serial Flash.

Figure 2-1. AT25QF641 Block Diagram

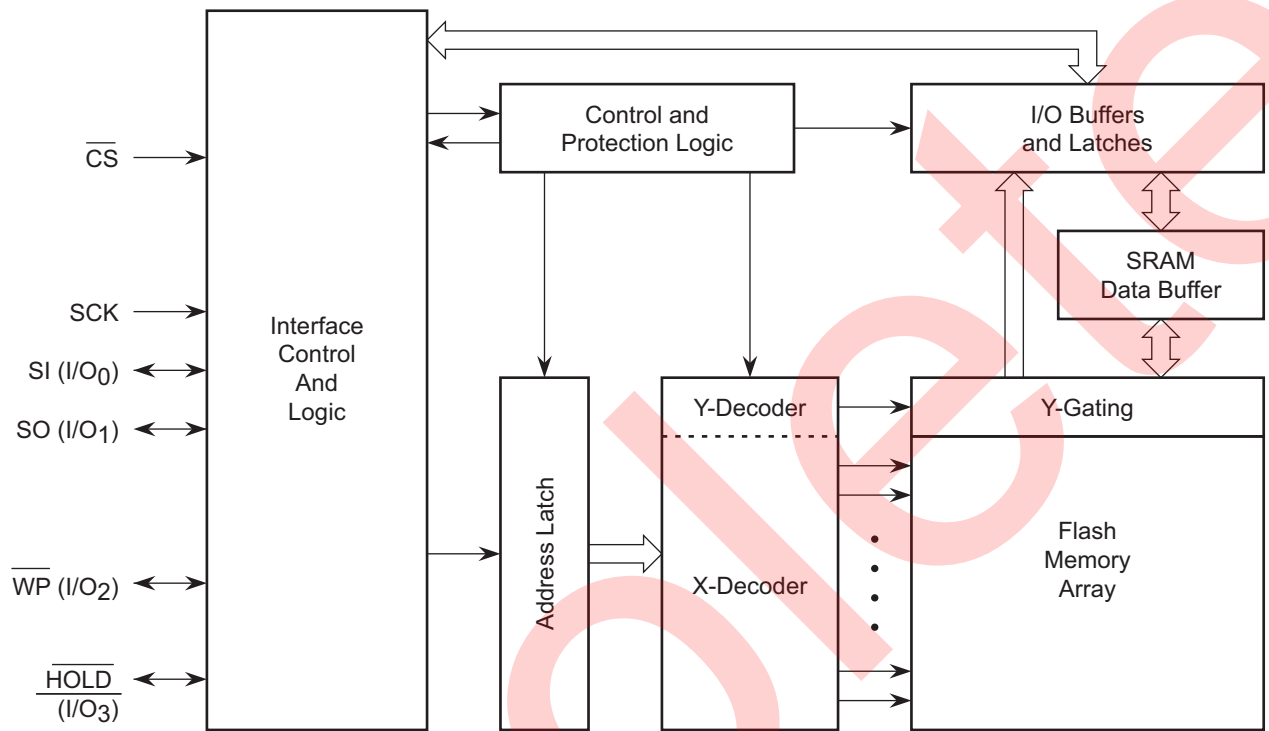

Note: I/O₃₋₀ pin naming convention is used for Dual-I/O and Quad-I/O commands.

3. Memory Array

To provide the greatest flexibility, the memory array of the AT25QF641 can be erased in four levels of granularity including a full chip erase. The size of the erase blocks is optimized for both code and data storage applications, allowing both code and data segments to reside in their own erase regions. The Memory Architecture Diagram below illustrates the breakdown of each erase level.

Figure 3-1. Memory Architecture Diagram

Block Erase Detail				Page Program Detail		
64KB	32KB	4KB	Block Address Range	1-256 byte	Page Address Range	
64KB	32KB	4KB	7FFFFFh – 7FF000h	256 bytes	7FFFFFh – 7FFF00h	
		4KB	7FEFFFh – 7FE000h	256 bytes	7FEFFFh – 7FFE00h	
		4KB	7FDFFFh – 7FD000h	256 bytes	7FDFFFh – 7FD000h	
		4KB	7FCFFFh – 7FC000h	256 bytes	7FCFFFh – 7FFC00h	
		4KB	7FBFFFh – 7FB000h	256 bytes	7FBFFFh – 7FFB00h	
		4KB	7FAFFFh – 7FA000h	256 bytes	7FAFFFh – 7FFA00h	
		4KB	7F9FFFh – 7F9000h	256 bytes	7F9FFFh – 7FF900h	
		4KB	7F8FFFh – 7F8000h	256 bytes	7F8FFFh – 7FF800h	
		4KB	7F7FFFh – 7F7000h	256 bytes	7F7FFFh – 7FF700h	
		4KB	7F6FFFh – 7F6000h	256 bytes	7F6FFFh – 7FF600h	
	32KB	4KB	7F5FFFh – 7F5000h	256 bytes	7F5FFFh – 7FF500h	
		4KB	7F4FFFh – 7F4000h	256 bytes	7F4FFFh – 7FF400h	
		4KB	7F3FFFh – 7F3000h	256 bytes	7F3FFFh – 7FF300h	
		4KB	7F2FFFh – 7F2000h	256 bytes	7F2FFFh – 7FF200h	
		4KB	7F1FFFh – 7F1000h	256 bytes	7F1FFFh – 7FF100h	
		4KB	7F0FFFh – 7F0000h	256 bytes	7F0FFFh – 7FF000h	
		4KB	7EFFFFh – 7EF000h	256 bytes	7EFFFFh – 7FEF00h	
		4KB	7EEDFFFh – 7EE000h	256 bytes	7EEDFFFh – 7FEE00h	
		4KB	7EDFFFh – 7ED000h	256 bytes	7EDFFFh – 7FED00h	
		4KB	7ECFFFh – 7EC000h	256 bytes	7ECFFFh – 7FEC00h	
64KB	32KB	4KB	7EBFFFh – 7EB000h	256 bytes	7EBFFFh – 7FEB00h	
		4KB	7EAFh – 7EA000h	256 bytes	7EAFh – 7FEA00h	
		4KB	7E9FFFh – 7E9000h	256 bytes	7E9FFFh – 7FE900h	
		4KB	7E8FFFh – 7E8000h	256 bytes	7E8FFFh – 7FE800h	
		4KB	7E7FFFh – 7E7000h	256 bytes	7E7FFFh – 7FE700h	
	32KB	4KB	7E6FFFh – 7E6000h	256 bytes	7E6FFFh – 7FE600h	
		4KB	7E5FFFh – 7E5000h	256 bytes	7E5FFFh – 7FE500h	
		4KB	7E4FFFh – 7E4000h	256 bytes	7E4FFFh – 7FE400h	
		4KB	7E3FFFh – 7E3000h	256 bytes	7E3FFFh – 7FE300h	
		4KB	7E2FFFh – 7E2000h	256 bytes	7E2FFFh – 7FE200h	
64KB	32KB	4KB	7E1FFFh – 7E1000h	256 bytes	7E1FFFh – 7FE100h	
		4KB	7E0FFFh – 7E0000h	256 bytes	7E0FFFh – 7FE000h	
		⋮	⋮	⋮	⋮	⋮
		4KB	00FFFFh – 00F000h	256 bytes	0017FFh – 001700h	
		4KB	00EFFFh – 00E000h	256 bytes	0016FFh – 001600h	
		4KB	00DFFFh – 00D000h	256 bytes	0015FFh – 001500h	
		4KB	00CFFFh – 00C000h	256 bytes	0014FFh – 001400h	
		4KB	00BFFFh – 00B000h	256 bytes	0013FFh – 001300h	
		4KB	00AFFh – 00A000h	256 bytes	0012FFh – 001200h	
		4KB	009FFFh – 009000h	256 bytes	0011FFh – 001100h	
64KB	32KB	4KB	008FFFh – 008000h	256 bytes	0010FFh – 001000h	
		4KB	007FFFh – 007000h	256 bytes	000FFFh – 000F00h	
		4KB	006FFFh – 006000h	256 bytes	000EFFh – 000E00h	
		4KB	005FFFh – 005000h	256 bytes	000DFFh – 000D00h	
		4KB	004FFFh – 004000h	256 bytes	000CFFh – 000C00h	
		4KB	003FFFh – 003000h	256 bytes	000BFFh – 000B00h	
		4KB	002FFFh – 002000h	256 bytes	000AFFh – 000A00h	
		4KB	001FFFh – 001000h	256 bytes	0009FFh – 000900h	
		4KB	000FFFh – 000000h	256 bytes	0008FFh – 000800h	
		4KB	000000h – 000000h	256 bytes	0007FFh – 000700h	
4KB	000000h – 000000h	256 bytes	0006FFh – 000600h			
4KB	000000h – 000000h	256 bytes	0005FFh – 000500h			
4KB	000000h – 000000h	256 bytes	0004FFh – 000400h			
4KB	000000h – 000000h	256 bytes	0003FFh – 000300h			
4KB	000000h – 000000h	256 bytes	0002FFh – 000200h			
4KB	000000h – 000000h	256 bytes	0001FFh – 000100h			
4KB	000000h – 000000h	256 bytes	0000FFh – 000000h			

4. Device Operation

4.1 Standard SPI Operation

The AT25QF641 features a serial peripheral interface on four signals: Serial Clock (SCK), Chip Select (\overline{CS}), Serial Data Input (SI) and Serial Data Output (SO). Standard SPI instructions use the SI input pin to serially write instructions, addresses or data to the device on the rising edge of SCK. The SO output pin is used to read data or status from the device on the falling edge of SCK.

SPI bus operation Modes 0 (0, 0) and 3 (1, 1) are supported. The primary difference between Mode 0 and Mode 3 concerns the normal state of the SCK signal when the SPI bus master is in standby and data is not being transferred to the Serial Flash. For Mode 0 the SCK signal is normally low on the falling and rising edges of \overline{CS} . For Mode 3 the SCK signal is normally high on the falling and rising edges of \overline{CS} .

4.2 Dual SPI Operation

The AT25QF641 supports Dual SPI operation. This instruction allows data to be transferred to or from the device at two times the rate of the standard SPI. The Dual Read instruction is ideal for quickly downloading code to RAM upon power-up (code-shadowing) or for executing non-speed-critical code directly from the SPI bus (XIP). When using Dual SPI instructions the SI and SO pins become bidirectional I/O pins; IO₀ and IO₁.

4.3 Quad SPI Operation

The AT25QF641 supports Quad SPI operation (factory default). This instruction allows data to be transferred to or from the device at four times the rate of the standard SPI. The Quad Read instruction offers a significant improvement in continuous and random access transfer rates allowing fast code-shadowing to RAM or execution directly from the SPI bus (XIP). When using Quad SPI instruction the SI and SO pins become bidirectional IO₀ and IO₁, and the \overline{WP} and \overline{HOLD} pins become IO₂ and IO₃ respectively. Quad SPI instructions require the non-volatile Quad Enable bit (QE) in Status Register-2 to be set.

4.4 QPI Operation

The AT25QF641 supports Quad Peripheral Interface (QPI) operation. The device is switched from Standard/Dual/Quad SPI mode to QPI mode using the Enable QPI (38h) instruction. Prior to executing the 38h instruction, software must first enable set the non-volatile Quad Enable bit (QE) in Status Register-2 to enable QPI mode. When using QPI instructions, the SI and SO pins become bidirectional IO₀ and IO₁, and the \overline{WP} and \overline{HOLD} pins become IO₂ and IO₃ respectively.

The typical SPI protocol requires that the byte-long instruction code being shifted into the device only via SI pin in eight serial clocks. The QPI mode utilizes all four IO pins to input the instruction code, thus only two serial clocks are required. This can significantly reduce the SPI instruction overhead and improve system performance in an XIP environment. Standard/ Dual/ Quad SPI mode and QPI mode are exclusive. Only one mode can be active at any given time, Enable QPI (38h) and Disable QPI (FFh) instructions are used to switch between these two modes. Upon power-up or after software reset using Reset (99h) instruction, the default state of the device is Standard/Dual/Quad SPI mode.

5. Write Protection

To protect inadvertent writes by the possible noise, several means of protection are applied to the Flash memory.

5.1 Write Protect Features

- While Power-on reset, all operations are disabled and no instruction is recognized.
- An internal time delay of t_{PUW} can protect the data against inadvertent changes while the power supply is outside the operating specification. This includes the Write Enable, Page program, Block Erase, Chip Erase, Write Security Register and the Write Status Register instructions.
- For data changes, Write Enable instruction must be issued to set the Write Enable Latch (WEL) bit to "0". Power-up, Completion of Write Disable, Write Status Register, Page program, Block Erase and Chip Erase are subjected to this condition.
- By setting the Status Register protect (SRP) and Block protect (SEC, TB, BP2, BP1, and BP0) bits, a portion of memory can be configured as read-only.
- Write Protect (\overline{WP}) pin can control to change the Status Register under hardware control.
- The Deep Power Down mode provides extra software protection from unexpected data changes as all instructions are ignored under this status except for the Release Deep Power Down (ABh) instruction.

6. Status Register

The Read Status Register instruction can be used to provide status on the availability of the Flash memory array, if the device is write enabled or disabled the state of write protection and the Quad SPI setting. The Write Status Register instruction can be used to configure the devices writes protection features and Quad SPI setting. Write access to the Status Register is controlled by in some cases of the WP pin.

Table 6-1. Status Register 1

S7	S6	S5	S4	S3	S2	S1	S0
SRP	SEC	TB	BP2	BP1	BP	WEL	BUSY
Status Register Protect 0 (Non-Volatile)	Sector Protect (Non-Volatile)	Top/Bottom Write Protect (Non-Volatile)	Block Protect (Non-Volatile)	Block Protect (Non-Volatile)	Block Protect (Non-Volatile)	Write Enable Latch	Erase or Write in Progress

Table 6-2. Status Register 2

S15	S14	S13	S12	S11	S10	S9	S8
SUS	CMP	(R)	(R)	(R)	(R)	QE	SRP1
Suspend Status	Complement Protect (Non-Volatile)	Reserved	Reserved	Reserved	Reserved	Quad Enable (Non-Volatile)	Status Register Protect 1 (Non-Volatile)

6.1 Busy

The BUSY bit is a read-only bit in the status register (S0) that is set to 1 by hardware when the device is executing a Page Program, Erase, Write Status Register or Write Security Register instruction. During this time the device ignores further instructions except for the Read Status Register and Erase / Program Suspend instruction (see t_W , t_{PP} , t_{SE} , t_{BE1} , t_{BE2} and t_{CE} in [Section 8.7, AC Electrical Characteristics](#)). When the Program, Erase, Write Status Register or Write Security Register instruction has completed, hardware clears the BUSY bit to 0, indicating the device is ready for further instructions.

6.2 Write Enable Latch (WEL)

The Write Enable Latch (WEL) is a read-only bit in the status register (S1) that is set to 1 by hardware when the Write Enable instruction is executed. Hardware clears the WEL status bit to 0 when device is write disabled. A write disable state occurs upon power-up or after any of the following instructions: Write Disable, Page Program, Erase and Write Status Register.

6.3 Block Protect Bits (BP2, BP1, BP0)

The Block Protect Bits (BP2, BP1, BP0) are non-volatile read/write bits in the status register (S4, S3, and S2) that provide write protection control and status. Block protect bits can be set using the Write Status Register Instruction (see t_W in [Section 8.7, AC Electrical Characteristics](#)). All, none or a portion of the memory array can be protected from Program and Erase instructions (see Status Register Memory Protection table). The factory default setting for the Block Protection Bits is 0, none of the array protected.

6.4 Top/Bottom Block protect (TB)

The Top/Bottom bit (TB) is non-volatile bits in the status register (S5) that controls if the Block Protect Bits (BP2, BP1, BP0) protect from the Top (TB = 0) or the Bottom (TB = 1) of the array as shown in the Status Register Memory Protection table. The factory default setting is TB = 0. The TB bit can be set with the Write Status Register Instruction depending on the state of the SRP0, SRP1 and WEL bits.

6.5 Sector/Block Protect (SEC)

The Sector protect bit (SEC) is non-volatile bits in the status register (S6) that controls if the Block Protect Bits (BP2, BP1, BP0) protect 4KB Sectors (SEC = 1) or 64KB Blocks (SEC = 0) in the Top (TB = 0) or the Bottom (TB = 1) of the array as shown in the Status Register Memory protection table. The default setting is SEC = 0.

6.6 Status Register Protect (SRP1, SRP0)

The Status Register Protect bits (SRP1 and SRP0) are non-volatile read/write bits in the status register (S8 and S7). The SRP bits control the method of write protection: software protection, hardware protection, power supply lock-down or one time programmable (OTP) protection.

Table 6-3. Encoding of SRP and WP Bits

SRP1	SRP0	\overline{WP}	Status Register	Description
0	0	X	Software Protection	The register can be written to and is not affected by the state of the \overline{WP} pin. [Factory Default]
0	1	0	Hardware Protected	When \overline{WP} pin is low the Status Register locked and cannot be written to.
0	1	1	Hardware Unprotected	When \overline{WP} pin is high the Status register is unlocked and can be written to after the WEL bit is set using the Write Enable (06h) instruction.
1	0	X	Power Supply Lock-Down	Status Register is protected and cannot be written to again until the next power down, power-up cycle. ⁽¹⁾
1	1	X	One Time Program	Status Register is permanently protected and cannot be written to.

1. When SRP1, SRP0 = (1,0), a power down, power-up cycle will change SRP1, SRP0 to the (0,0) state.

6.7 Quad Enable (QE)

The Quad Enable (QE) bit is a non-volatile read/write bit in the status register (S9) that allows Quad operation. When the QE bit is set to a 1 (factory default), pins 3 and 7 of the device are configured as bidirectional pins IO₂ and IO₃. **WARNING: The QE bit should never be set to a 1 during standard SPI or Dual SPI operation if the WP or HOLD pins are tied directly to the power supply or ground.**

6.8 Complement Protect (CMP)

The Complement Protect bit (CMP) is a non-volatile read/write bit in the status register (S14). It is used in conjunction with SEC, TB, BP2, BP1 and BP0 bits to provide more flexibility for the array protection. Once CMP is set to 1, previous array protection set by SEC, TB, BP2, BP1 and BP0 is reversed. For instance, when CMP = 0, a top 4 KB sector can be protected while the rest of the array is not; when CMP = 1, the top 4 KB sector becomes unprotected while the rest of the array become read-only. Please refer to the Status Register Memory Protection table for details. The default setting is CMP = 0.

6.9 Erase/Program Suspend Status (SUS)

The Suspend Status bit (SUS) is a read only bit in the status register (S15) that is set to 1 after executing an Erase/Program Suspend (75h) instruction. The SUS status bit can be cleared to 0 by executing an Erase/Program Resume (7Ah) instruction, as well as a power down, power-up cycle.

Table 6-4. Status Register Memory Protection (CMP = 0)

Status Register					Memory Protection			
SEC	TB	BP2	BP1	BP0	Block(s)	Addresses	Density	Portion
X	X	0	0	0	NONE	NONE	NONE	NONE
0	0	0	0	1	126 and 127	7E0000h-7FFFFFFh	128KB	Upper 1/64
0	0	0	1	0	124 thru 127	7C0000h-7FFFFFFh	256KB	Upper 1/32
0	0	0	1	1	120 thru 127	780000h-7FFFFFFh	512KB	Upper 1/16
0	0	1	0	0	112 thru 127	700000h-7FFFFFFh	1MB	Upper 1/8
0	0	1	0	1	96 thru 127	600000h-7FFFFFFh	2MB	Upper 1/4
0	0	1	1	0	64 thru 127	400000h-7FFFFFFh	4MB	Upper 1/2
0	1	0	0	1	0 and 1	000000h-01FFFFFFh	128KB	Lower 1/64
0	1	0	1	0	0 thru 3	000000h-03FFFFFFh	256KB	Lower 1/32
0	1	0	1	1	0 thru 7	000000h-07FFFFFFh	512KB	Lower 1/16
0	1	1	0	0	0 thru 15	000000h-0FFFFFFh	1MB	Lower 1/8
0	1	1	0	1	0 thru 31	000000h-1FFFFFFh	2MB	Lower 1/4
0	1	1	1	0	0 thru 63	000000h-3FFFFFFh	4MB	Lower 1/2
X	X	1	1	1	0 thru 127	000000h-7FFFFFFh	8MB	ALL
1	0	0	0	1	127	7FF000h-7FFFFFFh	4KB	U – 1/2048
1	0	0	1	0	127	7FE000h-7FFFFFFh	8KB	U – 1/1024
1	0	0	1	1	127	7FC000h-7FFFFFFh	16KB	U – 1/512
1	0	1	0	X	127	7F8000h-7FFFFFFh	32KB	U – 1/256
1	1	0	0	1	0	000000h-000FFFh	4KB	L – 1/2048
1	1	0	1	0	0	000000h-001FFFh	8KB	L – 1/1024
1	1	0	1	1	0	000000h-003FFFh	16KB	L – 1/512
1	1	1	0	X	0	000000h-007FFFh	32KB	L – 1/256

Note:

1. X = Don't care
2. L = Lower; U = Upper
3. If any Erase or Program instruction specifies a memory region that contains protected data portion, this instruction will be ignored.

Table 6-5. Status Register Memory Protection (CMP = 1)

Status Register					Memory Protection			
SEC	TB	BP2	BP1	BP0	Block(s)	Addresses	Density	Portion
X	X	0	0	0	0 thru 127	000000h - 7FFFFFFh	8MB	ALL
0	0	0	0	1	0 thru 125	000000h - 7DFFFFh	8,064KB	Lower 63/64
0	0	0	1	0	0 thru 123	000000h - 7BFFFFh	7,936KB	Lower 31/32
0	0	0	1	1	0 thru 119	000000h - 77FFFFh	7,680KB	Lower 15/16
0	0	1	0	0	0 thru 111	000000h - 6FFFFFFh	7,168KB	Lower 7/8
0	0	1	0	1	0 thru 95	000000h - 5FFFFFFh	6MB	Lower 3/4
0	0	1	1	0	0 thru 63	000000h - 3FFFFFFh	4MB	Lower 1/2
0	1	0	0	1	2 thru 127	020000h - 7FFFFFFh	8,064KB	Upper 63/64
0	1	0	1	0	4 and 127	040000h - 7FFFFFFh	7,936KB	Upper 31/32
0	1	0	1	1	8 thru 127	080000h - 7FFFFFFh	7,680KB	Upper 15/16
0	1	1	0	0	16 thru 127	100000h - 7FFFFFFh	7,168KB	Upper 7/8
0	1	1	0	1	32 thru 127	200000h - 7FFFFFFh	6MB	Upper 3/4
0	1	1	1	0	64 thru 127	400000h - 7FFFFFFh	4MB	Upper 1/2
X	X	1	1	1	NONE	NONE	NONE	NONE
1	0	0	0	1	0 thru 127	000000h - 7FEFFFh	8,188KB	L - 2047/2048
1	0	0	1	0	0 thru 127	000000h - 7FDFFFh	8,184KB	L - 1023/1024
1	0	0	1	1	0 thru 127	000000h - 7FBFFFh	8,176KB	L - 511/512
1	0	1	0	X	0 thru 127	000000h - 7F7FFFh	8,160KB	L - 255/256
1	1	0	0	1	0 thru 127	001000h - 7FFFFFFh	8,188KB	U - 2047/2048
1	1	0	1	0	0 thru 127	002000h - 7FFFFFFh	8,184KB	U - 1023/1024
1	1	0	1	1	0 thru 127	004000h - 7FFFFFFh	8,176KB	U - 511/512
1	1	1	0	X	0 thru 127	008000h - 7FFFFFFh	8,160KB	U - 255/256

Note:

1. X = don't care
2. L = Lower; U = Upper
3. If any Erase or Program instruction specifies a memory region that contains protected data portion, this instruction will be ignored.

7. Instructions

The SPI instruction set of the AT25QF641 consists of thirty eight basic instructions and the QPI instruction set of the AT25QF641 consists of thirty one basic instructions that are fully controlled through the SPI bus (see Instruction Set table). Instructions are initiated with the falling edge of Chip Select (CS). The first byte of data clocked into the input pins (SI or IO [3:0]) provides the instruction code. Data on the SI input is sampled on the rising edge of clock with most significant bit (MSB) first.

Instructions are completed with the rising edge of \overline{CS} . Clock relative timing diagrams for each instruction are included in the following subsections. However, all instructions that Write, Program or Erase must complete on a byte boundary (CS driven high after a full 8-bits have been clocked), otherwise the instruction is terminated. This feature further protects the device from inadvertent writes. Additionally, while the memory is being programmed or erased, or when the Status Register is being written, all instructions except for Read Register is ignored until the program or erase cycle has completed.

Table 7-1. Manufacturer and Device Identification

ID Type	Name	ID Code	Instruction(s)
Manufacturer ID	Dialog Semiconductor	1Fh	90h, 92h, 94h, 9Fh
Device ID	AT25QF641	16h	90h, 92h, 94h, ABh
Memory Type ID	SPI / QPI	32h	9Fh
Capacity Type ID	64M	17h	9Fh

7.1 Instruction Set Tables

The following tables list the instructions for the Single, Dual, Quad, and QPI modes of operation.

Table 7-2. Instruction Set Table 1 (SPI instructions)

Instruction Name (Clock Number)	Byte 0 (0 - 7)	Byte 1 (8 - 15)	Byte 2 (16 - 23)	Byte 3 (24 - 31)	Byte 4 (32 - 39)	Byte 5 (40 - 47)
Write Enable	06h					
Write Enable for Volatile Status Register	50h					
Write Disable	04h					
Read Status Register-1	05h	(SR7-SR0) ⁽²⁾				
Read Status Register-2	35h	(SR15-SR8) ⁽²⁾				
Write Status Register-1	01h	(SR7-SR0)	(SR15-SR8)			
Write Status Register-2	31h	(SR15-SR8)				
Read Data	03h	A23-A16	A15-A8	A7-A0	(D7-D0)	
Fast Read Data	0Bh	A23-A16	A15-A8	A7-A0	dummy	(D7-D0)
Page Program	02h	A23-A16	A15-A8	A7-A0	(D7-D0) ⁽³⁾	
Enable QPI	38h					
Block Erase (4 KB)	20h	A23-A16	A15-A8	A7-A0		
Block Erase (32 KB)	52h	A23-A16	A15-A8	A7-A0		

Table 7-2. Instruction Set Table 1 (SPI instructions) (Continued)

Instruction Name (Clock Number)	Byte 0 (0 - 7)	Byte 1 (8 - 15)	Byte 2 (16 - 23)	Byte 3 (24 - 31)	Byte 4 (32 - 39)	Byte 5 (40 - 47)
Block Erase (64 KB)	D8h	A23-A16	A15-A8	A7-A0		
Chip Erase	60h/C7h					
Erase/Program Suspend	75h					
Erase/Program Resume	7Ah					
Deep Power Down	B9h					
Release Deep Power Down/ Device ID ⁽⁴⁾	ABh	dummy	dummy	dummy	(ID7-ID0) ⁽²⁾	
Read Manufacturer/ Device ID ⁽⁴⁾	90h	00h	00h	00h or 01h	(MID7-MID0)	(DID7-DID0)
Read JEDEC ID	9Fh	(MID7-MID0) Manufacturer	(D7-D0) Memory Type	(D7-D0) Capacity Type		
Reset Enable	66h					
Reset	99h					
Enter Secured OTP	B1h					
Exit Secured OTP	C1h					
Read Security Register	2Bh	(SC7-SC0) ⁽¹⁰⁾				
Write Security Register	2Fh					
Read Serial Flash Discovery Parameter	5Ah	A23-A16	A15-A8	A7-A0	dummy	(D7-D0)

Table 7-3. Instruction Set Table 2 (Dual SPI Instructions)

Instruction Name (Clock Number)	Byte 0 (0 - 7)	Byte 1 (8 - 15)	Byte 2 (16 - 23)	Byte 3 (24 - 31)	Byte 4 (32 - 39)	Byte 5 (40 - 47)
Fast Read Dual Output	3Bh	A23-A16	A15-A8	A7-A0	dummy	(D7-D0) ⁽⁶⁾
Fast Read Dual I/O	BBh	A23-A8 ⁽⁵⁾	A7-A0, M7-M0 ⁽⁵⁾	(D7-D0, ...) ⁽⁶⁾		
Read Dual Manufacturer/ Device ID ⁽⁴⁾	92h	0000h	(00h, xxxx) or (01h, xxxx)	(MID7-MID0) (DID7-DID0) ⁽⁶⁾		

Table 7-4. Instruction Set Table 3 (Quad SPI Instructions)

Instruction Name (Clock Number)	Byte 0 (0 - 7)	Byte 1 (8 - 15)	Byte 2 (16 - 23)	Byte 3 (24 - 31)	Byte 4 (32 - 39)	Byte 5 (40 - 47)
Fast Read Quad Output	6Bh	A23-A16	A15-A8	A7-A0	dummy	(D7-D0) ⁽⁸⁾
Fast Read Quad I/O	EBh	A23-A0, M7-M0 ⁽⁷⁾	(xxx, D7-D0,...) ⁽⁹⁾	(D7-D0, ...) ⁽⁸⁾		
Quad Page Program	33h	A23-A0 (D7-D0, ...) ⁽⁸⁾				
Read Quad Manufacturer /Device ID ⁽⁴⁾	94h	(00_0000h, xx) or (00_0001h, xx)	(xxxx, MID7-MID0) (xxxx, DID7-DID0) ⁽⁹⁾			
Word Read Quad I/O	E7h	A23-A0, M7-M0 ⁽⁷⁾	(xx, D7-D0)	(D7-D0) ⁽⁸⁾		
Set Burst with Wrap	77h	xxxxxx, W6-W4 ⁽⁷⁾				

Table 7-5. Instruction Set Table 4 (QPI Instructions)

Instruction Name (Clock Number)	Byte 0 (0 - 7)	Byte 1 (8 - 15)	Byte 2 (16 - 23)	Byte 3 (24 - 31)	Byte 4 (32 - 39)	Byte 5 (40 - 47)	Byte 6 (48 - 55)	Byte 7 (56 - 63)	Byte 8 (64 - 71)
Write Enable	06h								
Write Enable for Volatile Status Register	50h								
Write Disable	04h								
Read Status Register-1	05h	(SR7-SR0) ⁽²⁾							
Read Status Register-2	35h	(SR15-SR8) ⁽²⁾							
Write Status Register-1 ⁽⁵⁾	01h	(SR7-SR0)	(SR15- SR8)						
Write Status Register-2	31h	(SR15-SR8)							
Fast Read Data	>80MHz	0Bh	A23-A16	A15-A8	A7-A0	dummy	dummy	(D7-D0)	
	>104MHz		A23-A16	A15-A8	A7-A0	dummy	dummy	dummy	(D7-D0)
Page Program	02h	A23-A16	A15-A8	A7-A0	(D7-D0) ⁽³⁾				
Block Erase(4KB)	20h	A23-A16	A15-A8	A7-A0					
Block Erase(32KB)	52h	A23-A16	A15-A8	A7-A0					
Block Erase(64KB)	D8h	A23-A16	A15-A8	A7-A0					
Chip Erase	60h/ C7h								
Erase/Program Suspend	75h								
Erase/Program Resume	7Ah								

Table 7-5. Instruction Set Table 4 (QPI Instructions) (Continued)

Instruction Name	Byte 0	Byte 1	Byte 2	Byte 3	Byte 4	Byte 5	Byte 6	Byte 7	Byte 8
(Clock Number)	(0 - 7)	(8 - 15)	(16 - 23)	(24 - 31)	(32 - 39)	(40 - 47)	(48 - 55)	(56 - 63)	(64 - 71)
Deep Power Down	B9h								
Release Deep Power Down	ABh								
Read Manufacturer/Device ID ⁽⁴⁾	90h	00h	00h	00h or 01h	(MID7-MID0)	(DID7-DID0)			
Read JEDEC ID ⁽⁴⁾	9Fh	(MID7- MID0) Manufacturer	(D7-D0) Memory Type	(D7-D0) Capacity Type					
Enter Security	B1h								
Exit Security	C1h								
Read Security Register	2Bh	(SC7-SC0) ⁽¹⁰⁾							
Write Security Register	2Fh								
Fast Read Quad I/O	>80 MHz	EBh	A23-A16	A15-A8	A7-A0	(M7-M0)	dummy	(D7-D0)	
	>104 MHz		A23-A16	A15-A8	A7-A0	(M7-M0)	dummy	dummy	(D7-D0)
Reset Enable	66h								
Reset	99h								
Disable QPI	FFh								
Burst Read with Wrap	>80 MHz	0Ch	A23-A16	A15-A8	A7-A0	dummy	dummy	(D7-D0)	
	>104 MHz		A23-A16	A15-A8	A7-A0	dummy	dummy	dummy	(D7-D0)
Set Read Parameter	C0h	P7-P0							
Quad Page Program	33h	A23-A16	A15-A8	A7-A0	(D7-D0)				

Notes:

- Data bytes are shifted with Most Significant Bit first. Byte fields with data in parenthesis “()” indicate data being read from the device on the IO pin.
- SR = status register, The Status Register contents and Device ID will repeat continuously until \overline{CS} terminates the instruction.
- At least one byte of data input is required for Page Program, Quad Page Program and Program Security Register, up to 256 bytes of data input. If more than 256 bytes of data are sent to the device, the addressing will wrap to the beginning of the page and overwrite previously sent data.
- See Manufacturer and Device Identification table for Device ID information.
- Dual Input Address
 IO0 = A22, A20, A18, A16, A14, A12, A10, A8, A6, A4, A2, A0, M6, M4, M2, M0
 IO1 = A23, A21, A19, A17, A15, A13, A11, A9, A7, A5, A3, A1, M7, M5, M3, M1
- Dual Output data
 IO0 = (D6, D4, D2, D0)
 IO1 = (D7, D5, D3, D1)
- Quad Input Address

IO0 = A20, A16, A12, A8, A4, A0, M4, M0	Set Burst with Wrap Input
IO1 = A21, A17, A13, A9, A5, A1, M5, M1	IO0 = x, x, x, x, x, x, W4, x
IO2 = A22, A18, A14, A10, A6, A2, M6, M2	IO1 = x, x, x, x, x, x, W5, x
IO3 = A23, A19, A15, A11, A7, A3, M7, M3	IO2 = x, x, x, x, x, x, W6, x
	IO3 = x, x, x, x, x, x, x, x
- Quad Input/ Output Data
 IO0 = (D4, D0...)

IO1 = (D5, D1...)
 IO2 = (D6, D2...)
 IO3 = (D7, D3...)

9. Fast Read Quad I/O Data Output
 IO0 = (x, x, x, x, D4, D0...)
 IO1 = (x, x, x, x, D5, D1...)
 IO2 = (x, x, x, x, D6, D2...)
 IO3 = (x, x, x, x, D7, D3...)
10. SC = security register

7.2 Write Enable (06h)

Write Enable instruction is for setting the Write Enable Latch (WEL) bit in the Status Register. The WEL bit must be set prior to every Program, Erase and Write Status Register instruction. To execute the Write Enable instruction, drive \overline{CS} low, followed by 06h being driven onto the SI pin on the rising edge of SCK, and then driving \overline{CS} high.

Figure 7-1. Write Enable Instruction for SPI Mode (left) and QPI Mode (right)

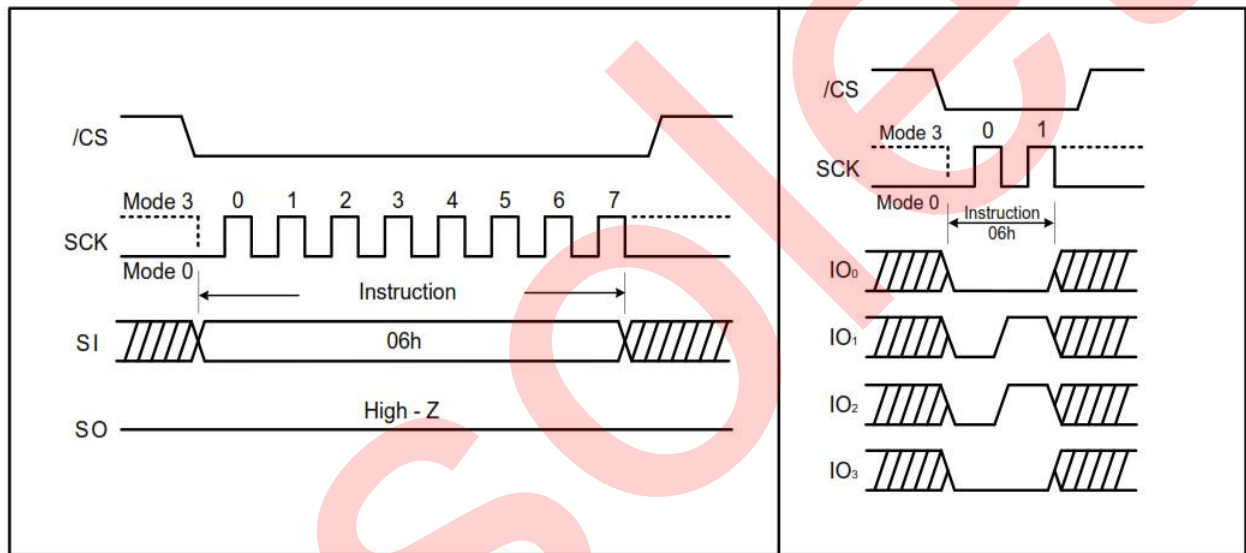

7.3 Write Enable for Volatile Status Register (50h)

This gives more flexibility to change the system configuration and memory protection schemes quickly without waiting for the typical non-volatile bit write cycles or affecting the endurance of the Status Register non-volatile bits. To write the volatile values into the Status Register bits, the Write Enable for Volatile Status Register (50h) instruction must be issued prior to a Write Status Register (01h) instruction. Write Enable for Volatile Status Register instruction (Figure 7-2) does not set the Write Enable Latch (WEL) bit. Once Write Enable for Volatile Status Register is set, a Write Enable instruction should not have been issued prior to setting Write Status Register instruction (01h or 31h).

Figure 7-2. Write Enable for Volatile Status Register Instruction for SPI Mode (left) and QPI Mode (right)

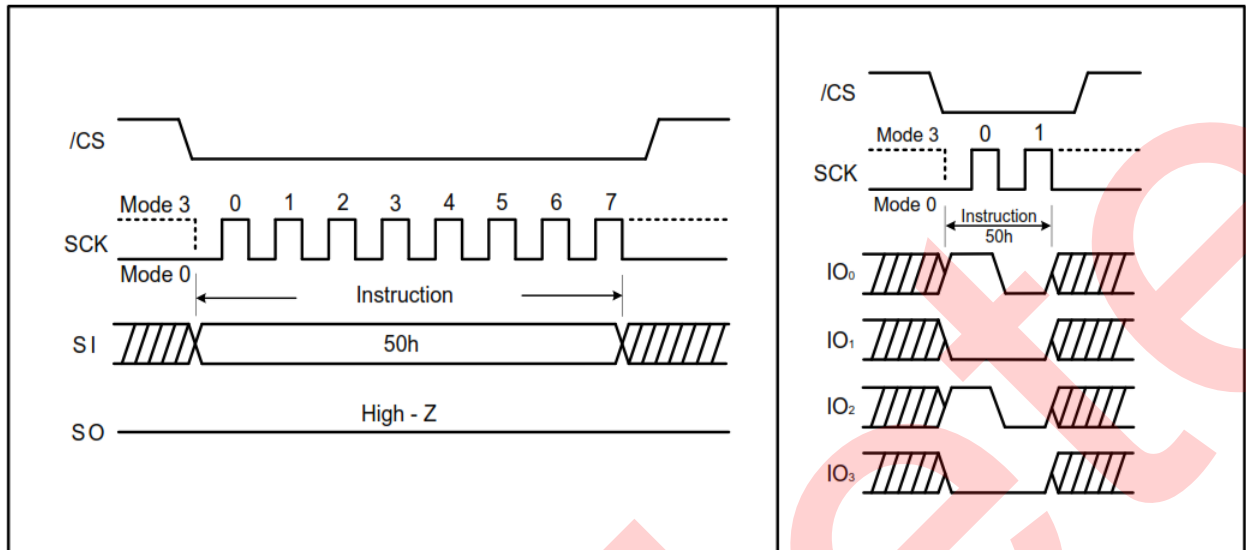

7.4 Write Disable (04h)

The Write Disable instruction is to reset the Write Enable Latch (WEL) bit in the Status Register. To enter the Write Disable instruction, \overline{CS} goes low prior to the instruction 04h being driven onto the SI pin on the rising edge of SCK, and then driving \overline{CS} high. The WEL bit is automatically reset by hardware after Power-up and upon completion of the every Program, Erase and Write Status Register instruction.

Figure 7-3. Write Disable Instruction for SPI Mode (left) and QPI Mode (right)

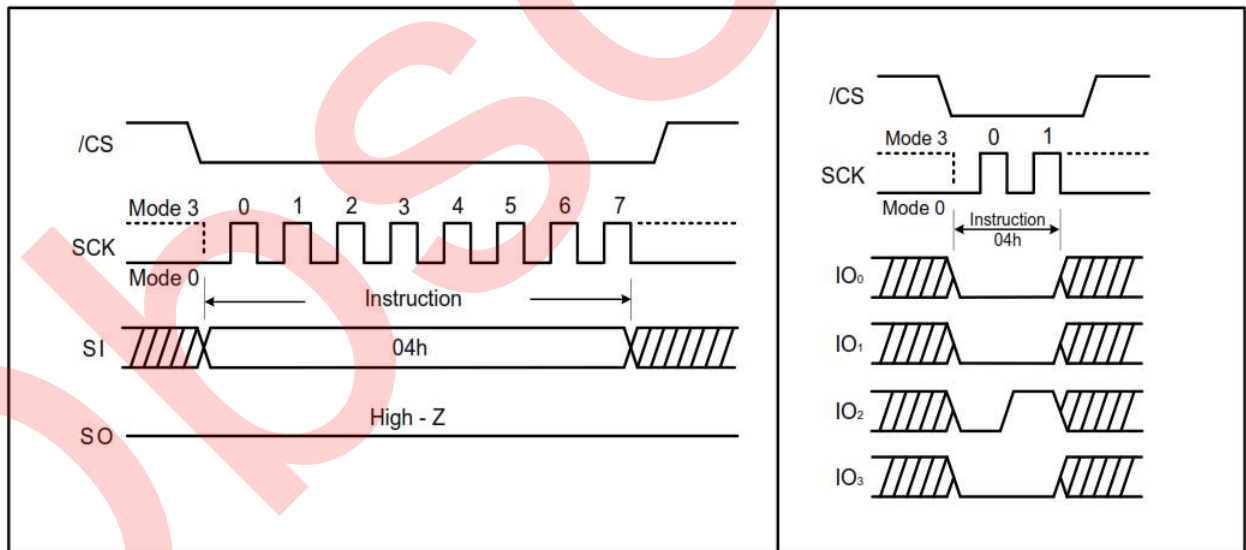

7.5 Read Status Register-1 (05h) and Read Status Register-2 (35h)

The Read Status Register instructions are to read the Status Register. The Read Status Register can be read at any time (even in program/erase/write Status Register and Write Security Register condition). It is recommended to check the BUSY bit before sending a new instruction when a Program, Erase, Write Status Register or Write Status Register operation is in progress.

The instruction is entered by driving \overline{CS} low and driving the instruction code 05h for Status Register-1 or 35h for Status Register-2 onto the SI pin on the rising edge of SCK. In SPI mode, the Status register bits are then shifted out on the SO pin at the falling edge of SCK with the most significant bit (MSB) first as shown in **Figure 7-4**.

In QPI mode, the Status register bits are then shifted out on the IO₀ - IO₃ pins at the falling edge of SCK with the most significant bit (MSB) first as shown in **Figure 7-5**. In QPI mode, bits 7:4 of the Status register are shifted out in one clock, and bits 3:0 are shifted out on the following clock. This allows the field to be read in only two clock cycles instead of eight with SPI mode.

The Status Register can be read continuously. The instruction is completed by driving \overline{CS} high.

Figure 7-4. Read Status Register Instruction (SPI Mode)

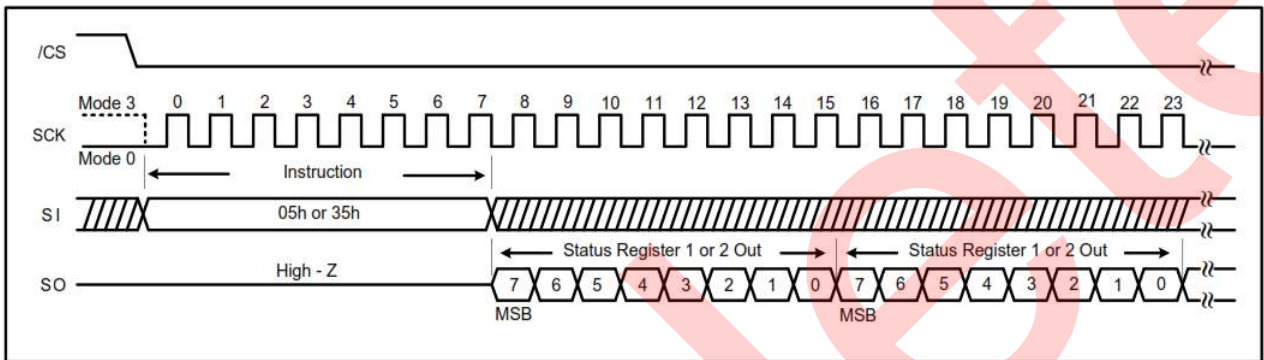
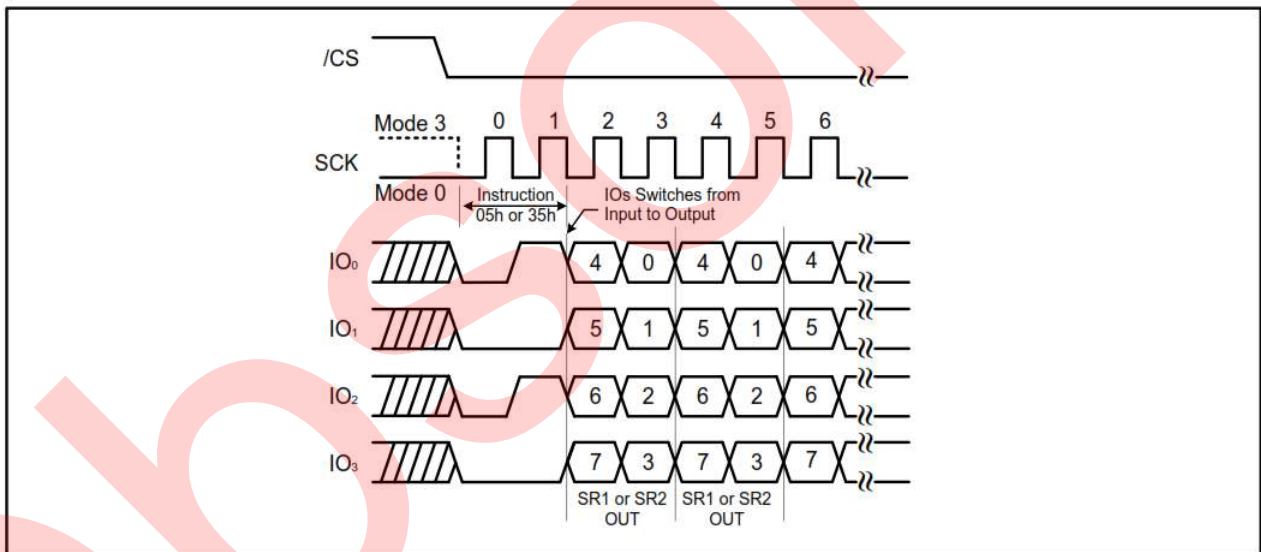

Figure 7-5. Read Status Register Instruction (QPI Mode)



7.6 Write Status Register (01h)

The Write Status Register instruction is to write only non-volatile Status Register-1 bits (SRP0, SEC, TB, BP2, BP1 and BP0) and Status Register-2 bits (CMP, QE and SRP1). All other Status Register bit locations are read-only and are not affected by the Write Status Register instruction.

A Write Enable instruction must previously have been issued prior to setting Write Status Register Instruction (Status Register bit WEL must equal 1). Once write is enabled, the instruction is entered by driving \overline{CS} low, sending the instruction code, and then writing the status register data byte as illustrated in **Figure 7-6** and **Figure 7-7**.

The \overline{CS} pin must be driven high after the eighth or sixteenth bit of data that is clocked in. If this is not done the Write Status Register instruction will not be executed. If \overline{CS} is driven high after the eighth clock, the CMP, QE, and SRP1 bits

are cleared to 0. After \overline{CS} is driven high, the self-timed Write Status Register cycle commences for a time duration of t_{w} (See [Section 8.7, AC Electrical Characteristics](#)).

While the Write Status Register cycle is in progress, the Read Status Register instruction can still be accessed to check the status of the BUSY bit. The BUSY bit is 1 during the Write Status Register cycle and 0 when the cycle is finished and again ready to accept other instructions. When the BUSY bit is asserted, the Write Enable Latch (WEL) bit in Status Register will be cleared to 0.

Figure 7-6. Write Status Register Instruction (SPI Mode)

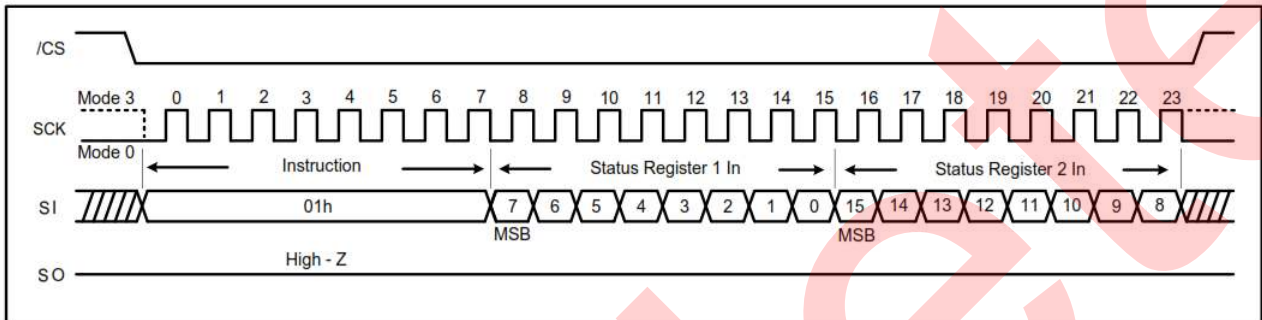
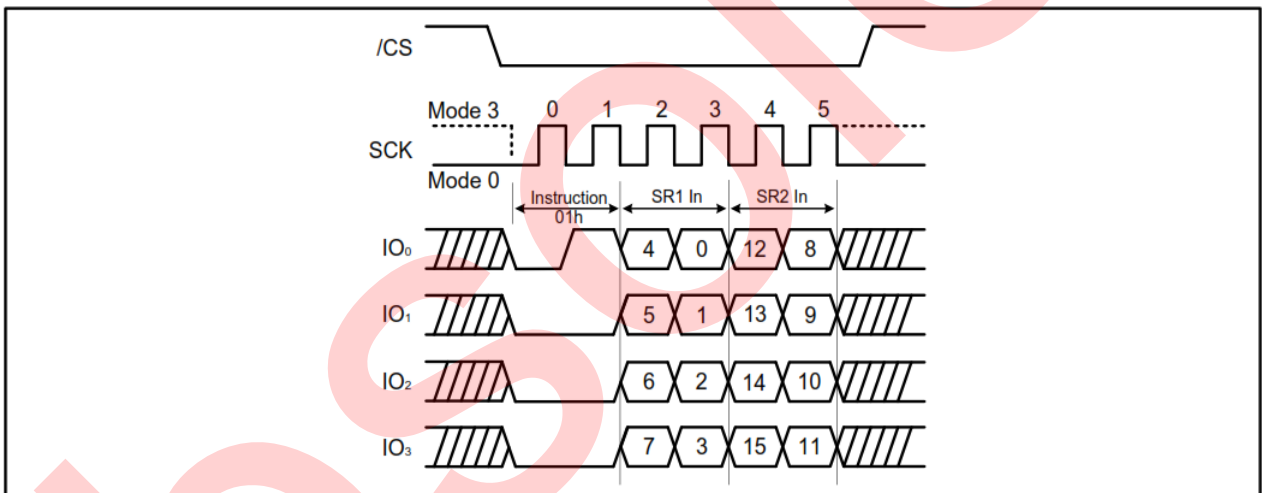

Figure 7-7. Write Status Register Instruction (QPI Mode)



7.7 Write Status Register-2 (31h)

The Write Status Register-2 instruction is to write only non-volatile Status Register-2 bits (CMP, QE and SRP1).

A Write Enable (06h) instruction must have previously been issued prior to executing the Write Status Register Instruction (Status Register bit WEL must equal 1). Once the WEL bit is set, the instruction is executed by driving \overline{CS} low, sending the instruction code, and then writing the status register data byte as illustrated in [Figure 7-8](#) and [Figure 7-9](#).

Using Write Status Register-2 (31h) instruction, software can individually access each one-byte status registers via different instructions.

Figure 7-8. Write Status Register-2 Instruction (SPI Mode)

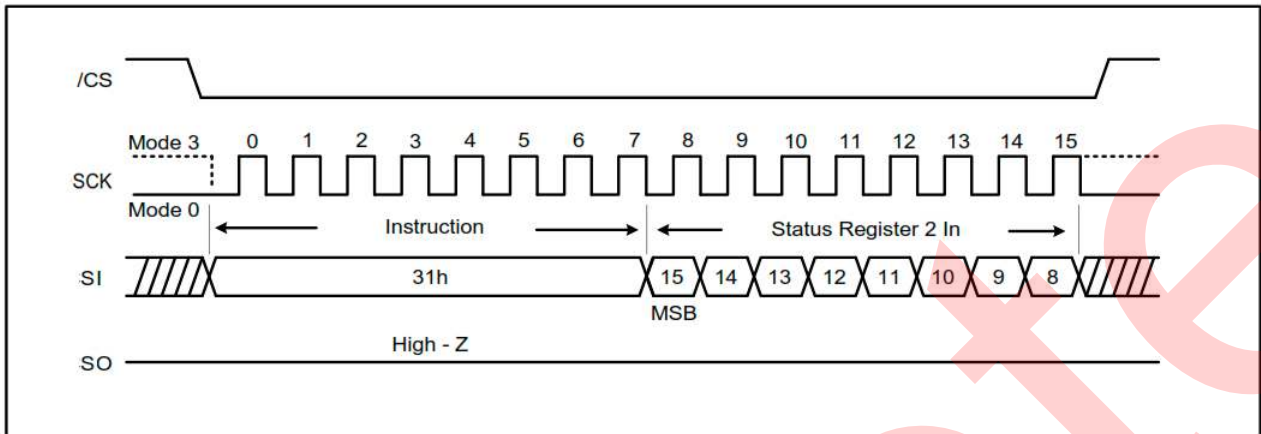
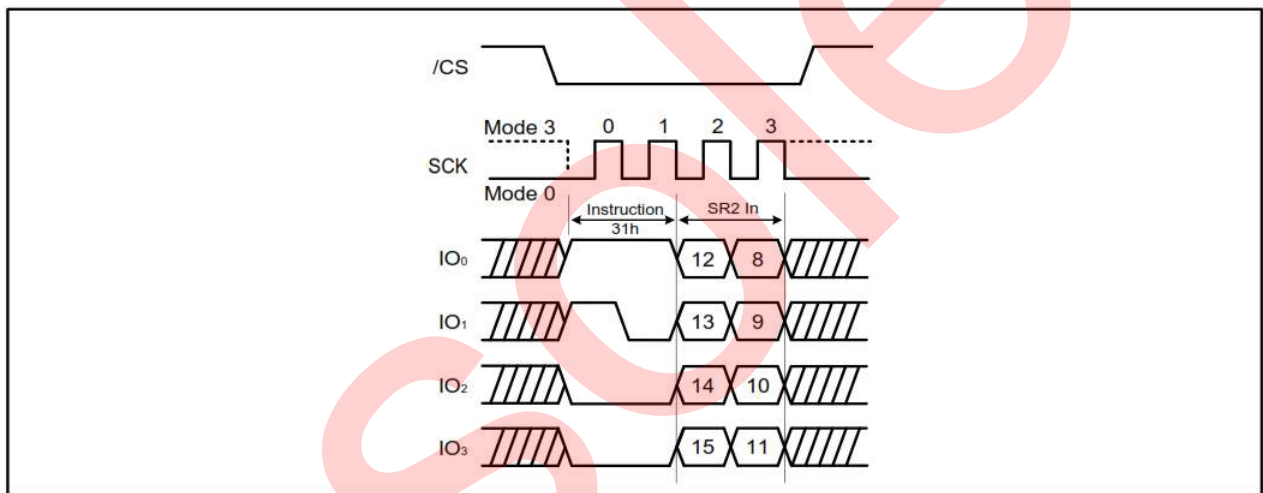

Figure 7-9. Write Status Register-2 Instruction (QPI Mode)



7.8 Read Data (03h)

The Read Data instruction is to read data out from the device. The instruction is initiated by driving the $\overline{\text{CS}}$ pin low and then sending the instruction code 03h followed by a 24-bit address (A23- A0) onto the SI pin. After the address is received, the data byte of the addressed memory location is shifted out on the SO pin at the falling edge of SCK with most significant bit (MSB) first. The address is automatically incremented to the next higher address after a byte of data is shifted out allowing for a continuous stream of data. This means that the entire memory can be accessed with a single instruction as long as the clock continues.

The instruction is completed by driving $\overline{\text{CS}}$ high. The Read Data instruction sequence is shown in [Figure 7-10](#). If a Read Data instruction is issued while an Erase, Program or Write Status Register cycle is in process (BUSY = 1) the instruction is ignored and will not have any effects on the current cycle. The Read Data instruction allows clock rates from D.C to a maximum of f_{R} (see [Section 8.7, AC Electrical Characteristics](#)).

Figure 7-10. Read Data Instruction

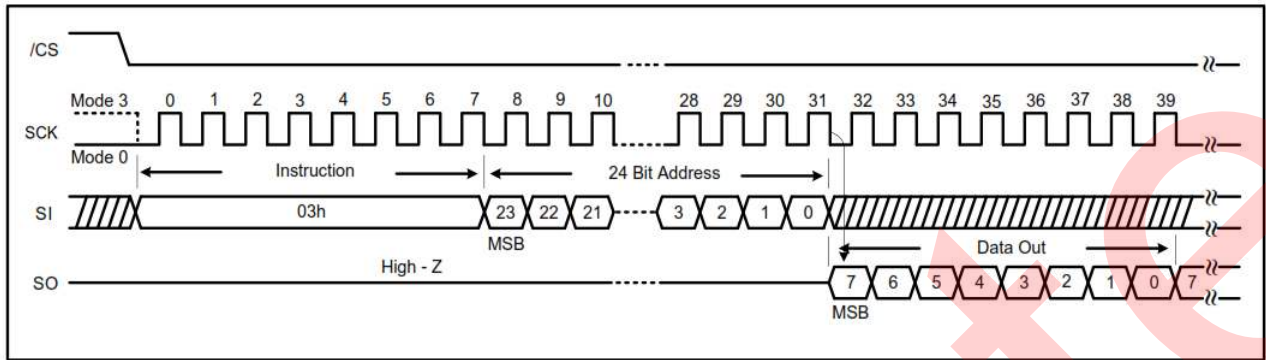

7.9 Fast Read (0Bh)

The Fast Read instruction is high speed reading mode that it can operate at the highest possible frequency of F_R . The address is latched on the rising edge of the SCK. After the 24-bit address, this is accomplished by adding “dummy” clocks as shown in [Figure 7-11](#). The dummy clocks means the internal circuits require time to set up the initial address. During the dummy clocks, the data value on the SO pin is a “don’t care”. Data of each bit shifts out on the falling edge of SCK.

Figure 7-11. Fast Read Instruction (SPI Mode)

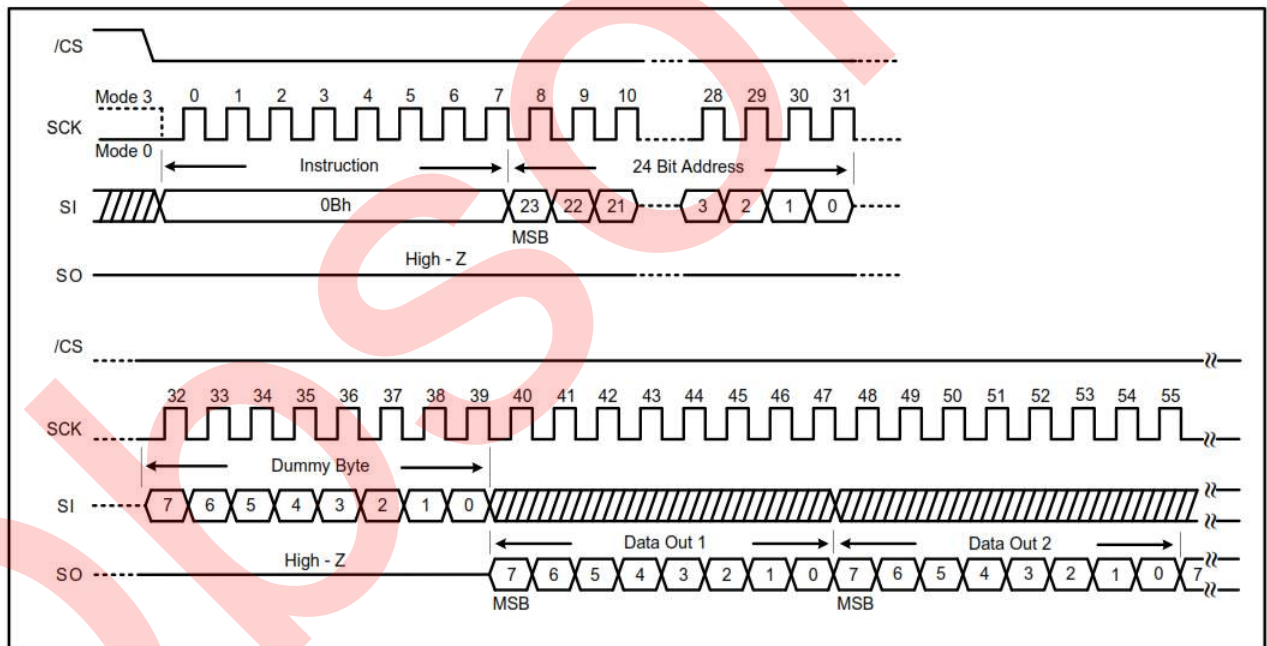

7.10 Fast Read in QPI Mode

When QPI mode is enabled, the number of dummy clock is configured by the Set Read Parameters (C0h) instruction to accommodate wide range applications with different needs for either maximum Fast Read frequency or minimum data access latency. Depending on the Read Parameter Bit P[4] and P[5] setting, the number of dummy clocks can be configured as either 4, or 6 or 8. The default number of dummy clocks upon power up or after a Reset instruction is 4. Please refer to [Figure 7-12](#) and [Figure 7-13](#).

Figure 7-12. Fast Read instruction (QPI Mode, 80 MHz)

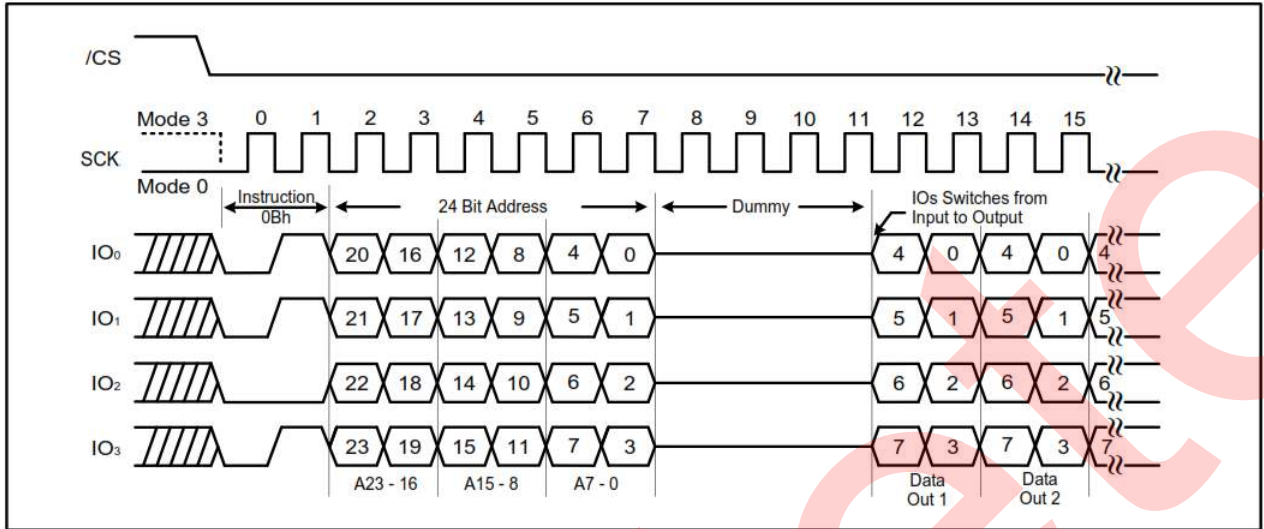
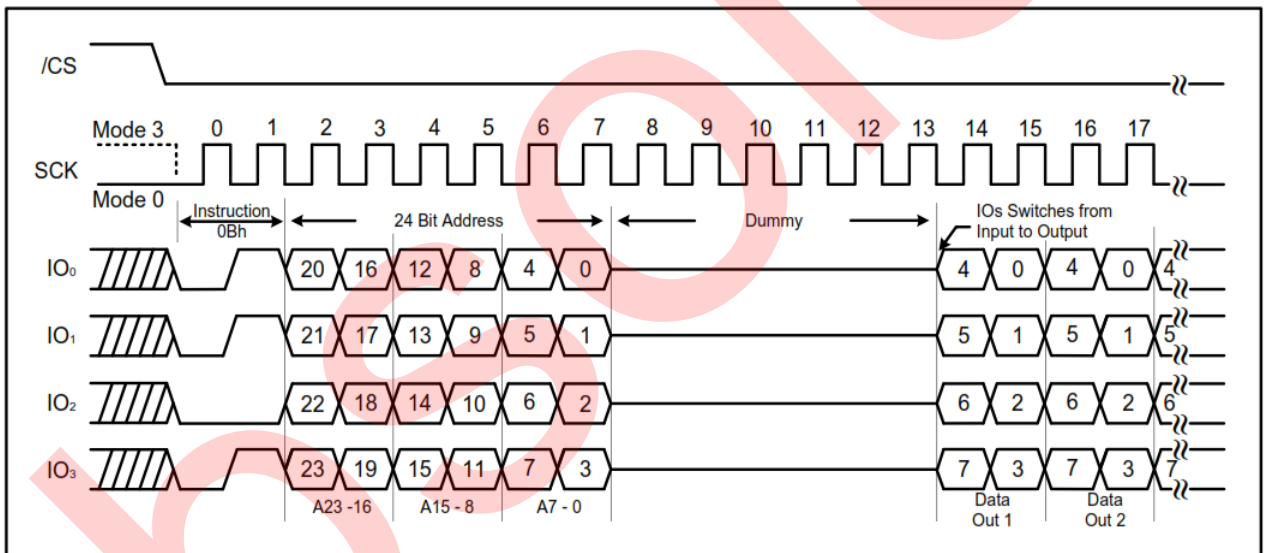

Figure 7-13. Fast Read instruction (QPI Mode, 104 MHz)



7.11 Fast Read Dual Output (3Bh)

By using two pins (IO₀ and IO₁, instead of just IO₀), The Fast Read Dual Output instruction allows data to be transferred from the AT25QF641 at twice the rate of standard SPI devices. The Fast Read Dual Output instruction is ideal for quickly downloading code from Flash to RAM upon power-up or for application that cache code-segments to RAM for execution.

The Fast Read Dual Output instruction can operate at the highest possible frequency of F_R (see AC Electrical Characteristics). After the 24-bit address, this is accomplished by adding eight “dummy” clocks as shown in [Figure 7-14](#). The dummy clocks allow the internal circuits additional time for setting up the initial address. During the dummy clocks, the data value on the SO pin is a “don’t care”. However, the IO₀ pin should be high-impedance prior to the falling edge of the first data out clock.

Figure 7-14. Fast Read Dual Output instruction (SPI Mode)

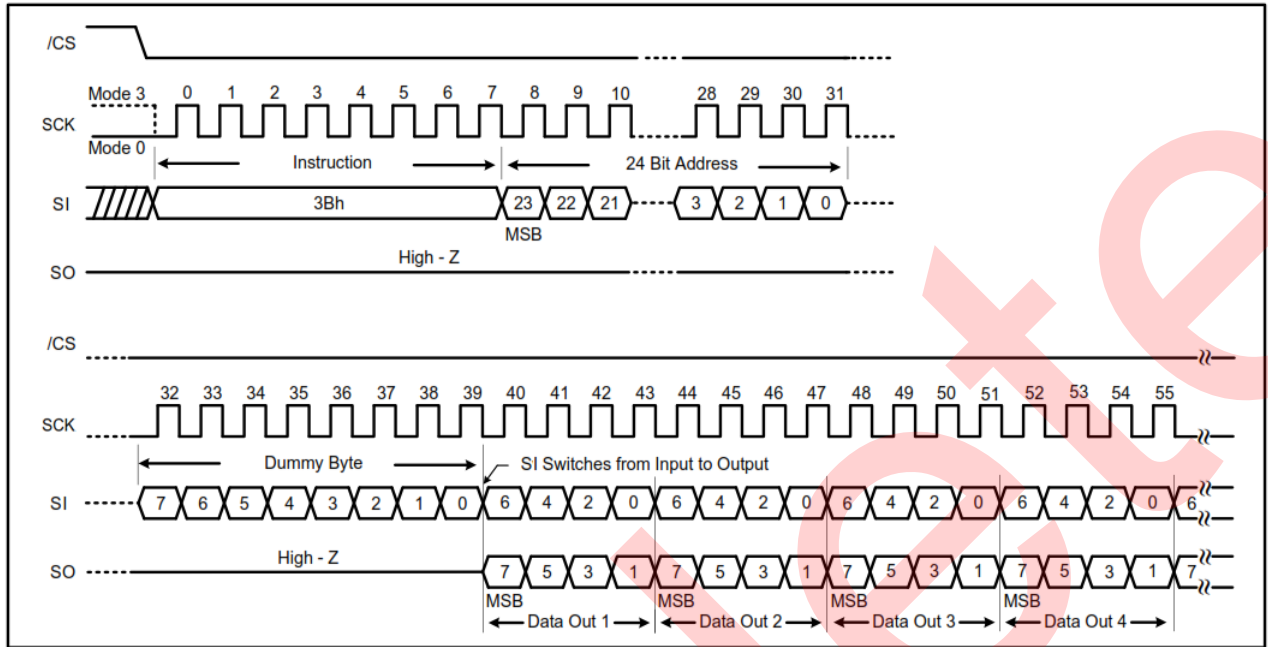

7.12 Fast Read Quad Output (6Bh)

By using four pins (IO₀, IO₁, IO₂, and IO₃), The Fast Read Quad Output instruction allows data to be transferred from the AT25QF641 at four times the rate of standard SPI devices. A Quad enable of Status Register-2 must be executed before the device can accept the Fast Read Quad Output instruction (Status Register bit QE must equal 1).

The Fast Read Quad Output instruction can operate at the highest possible frequency of F_R (see [Section 8.7, AC Electrical Characteristics](#)). This is accomplished by adding eight “dummy” clocks after the 24-bit address as shown in [Figure 7-15](#). The dummy clocks allow the internal circuits additional time for setting up the initial address. During the dummy clocks, the data value on the SO pin is a “don’t care”. However, the IO₀ pin should be high-impedance prior to the falling edge of the first data out clock.

Figure 7-15. Fast Read Quad Output Instruction (SPI Mode)

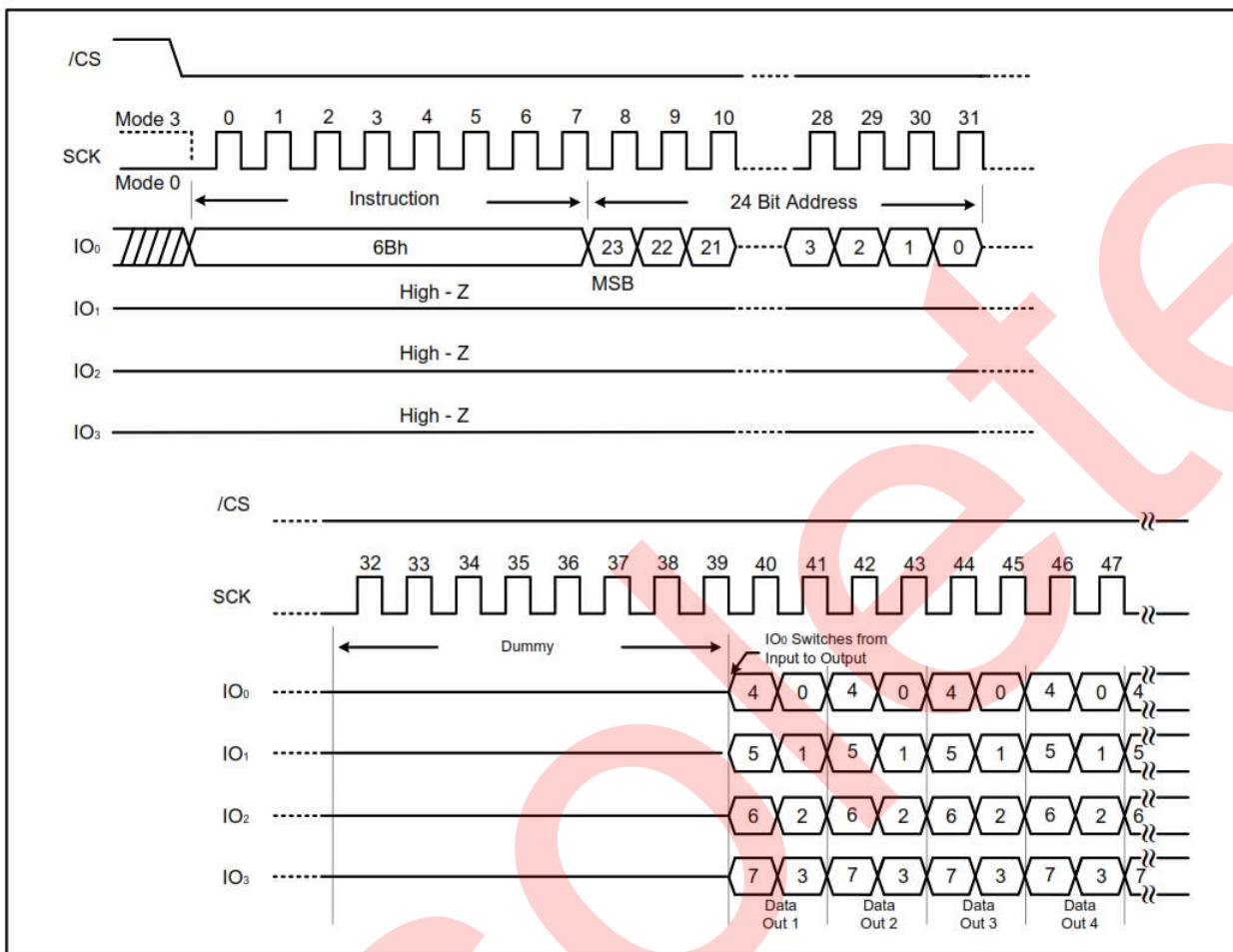

7.13 Fast Read Dual I/O (BBh)

The Fast Read Dual I/O instruction reduces cycle overhead through double access using two IO pins: IO₀ and IO₁.

Continuous read mode

The Fast Read Dual I/O instruction can further reduce cycle overhead through setting the Mode bits (M7-0) after the input address bits (A23-0). The upper nibble of the Mode (M7-4) controls the length of the next Fast Read Dual I/O instruction through the inclusion or exclusion of the first byte instruction code. The lower nibble bits of the Mode (M3-0) are don't care ("X"), However, the IO pins should be high-impedance prior to the falling edge of the first data out clock.

If the Mode bits (M7-0) are equal to 'Ax' hex, then the next Fast Dual I/O instruction (after \overline{CS} is raised and then lowered) does not require the instruction (BBh) code, as shown in [Figure 7-16](#) and [Figure 7-17](#). This reduces the instruction sequence by eight clocks and allows the address to be immediately entered after \overline{CS} is asserted low. If Mode bits (M7-0) are any value other than 'Ax' hex, the next instruction (after \overline{CS} is raised and then lowered) requires the first byte instruction code, thus returning to normal operation. A Mode Bit Reset can be used to reset Mode Bits (M7-0) before issuing normal instructions.

Figure 7-16. Fast Read Dual I/O Instruction (initial instruction or previous M7-0 \neq Axh)

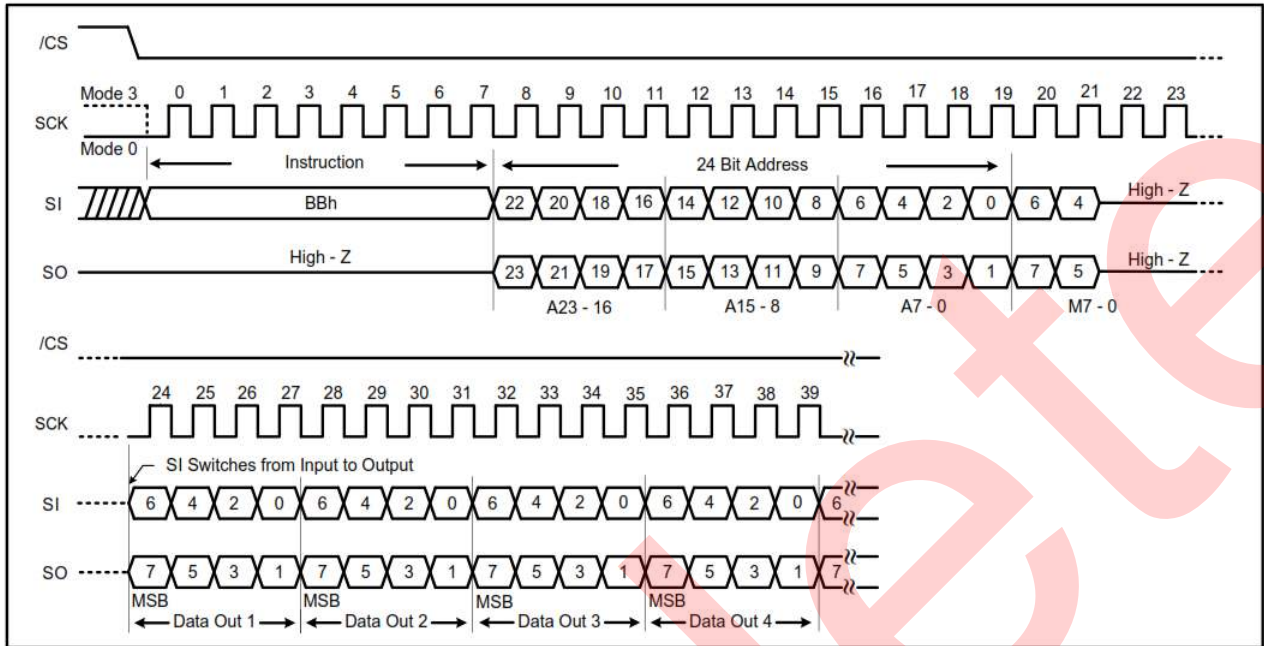
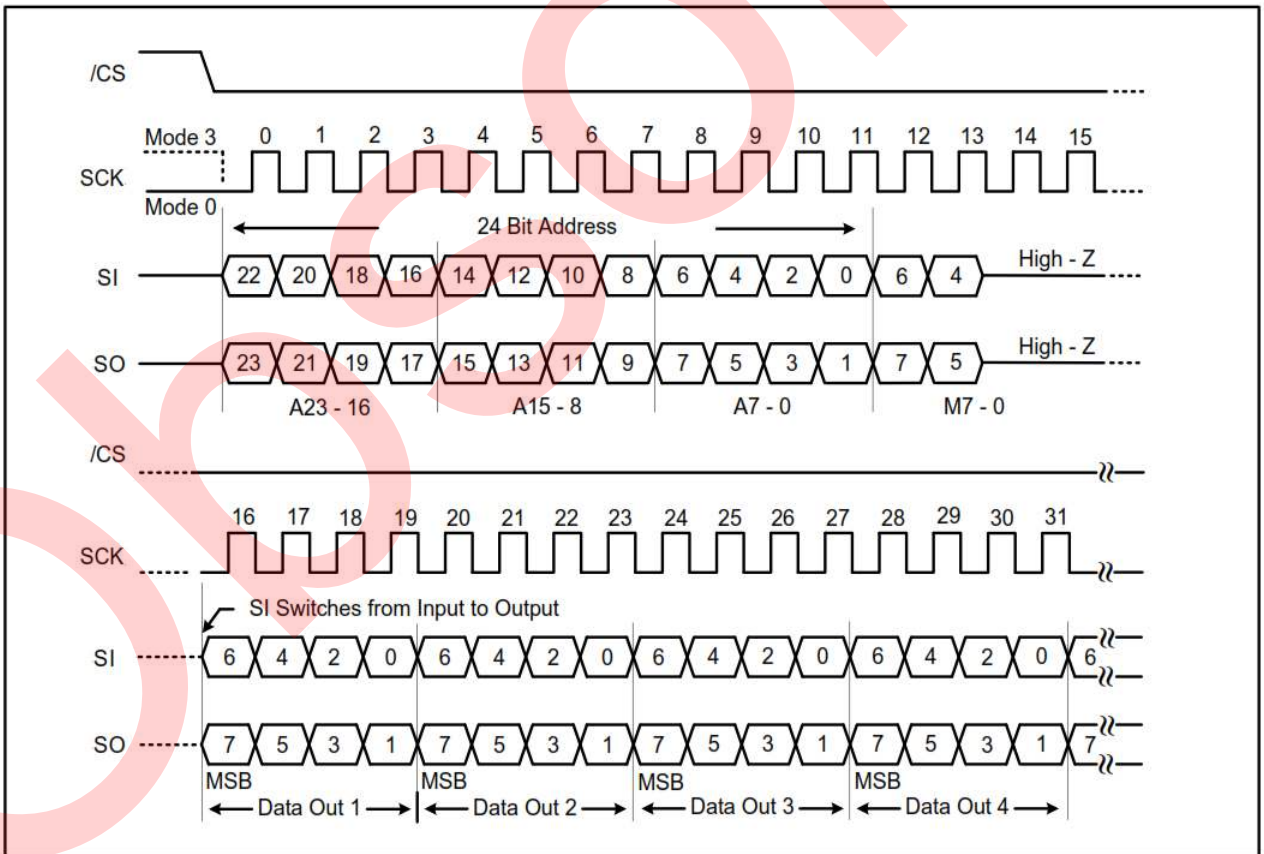

Figure 7-17. Fast Read Dual I/O Instruction (previous M7-0 = Axh)



7.14 Fast Read Quad I/O (EBh)

The Fast Read Quad I/O instruction reduces cycle overhead through quad access using four IO pins: IO₀, IO₁, IO₂, and IO₃. The Quad Enable bit (QE) of Status Register-2 must be set to enable the Fast read Quad I/O Instruction.

Continuous read mode

The Fast Read Quad I/O instruction can further reduce instruction overhead through setting the Mode bits (M7-0) with following the input Address bits (A23-0), as shown in **Figure 7-18**. The upper nibble of the Mode (M7-4) controls the length of the next Fast Read Quad I/O instruction through the inclusion or exclusion of the first byte instruction code. The lower nibble bits of the Mode (M3-0) are don't care ("X"). However, the IO pins should be high-impedance prior to the falling edge of the first data out clock.

If the Mode bits (M7-0) are equal to 'Ax' hex, then the next Fast Read Quad I/O instruction (after \overline{CS} is raised and then lowered) does not require the EBh instruction code, as shown in **Figure 7-19**. This reduces the instruction sequence by eight clocks and allows the address to be immediately entered after \overline{CS} is asserted low. If the Mode bits (M7-0) are any value other than 'Ax' hex, the next instruction (after \overline{CS} is raised and then lowered) requires the first byte instruction code, thus retuning normal operation. A Mode Bit Reset can be used to reset Mode Bits (M7-0) before issuing normal instructions.

Figure 7-18. Fast Read Quad I/O Instruction (Initial instruction or previous M7-0 ≠ Axh, SPI mode)

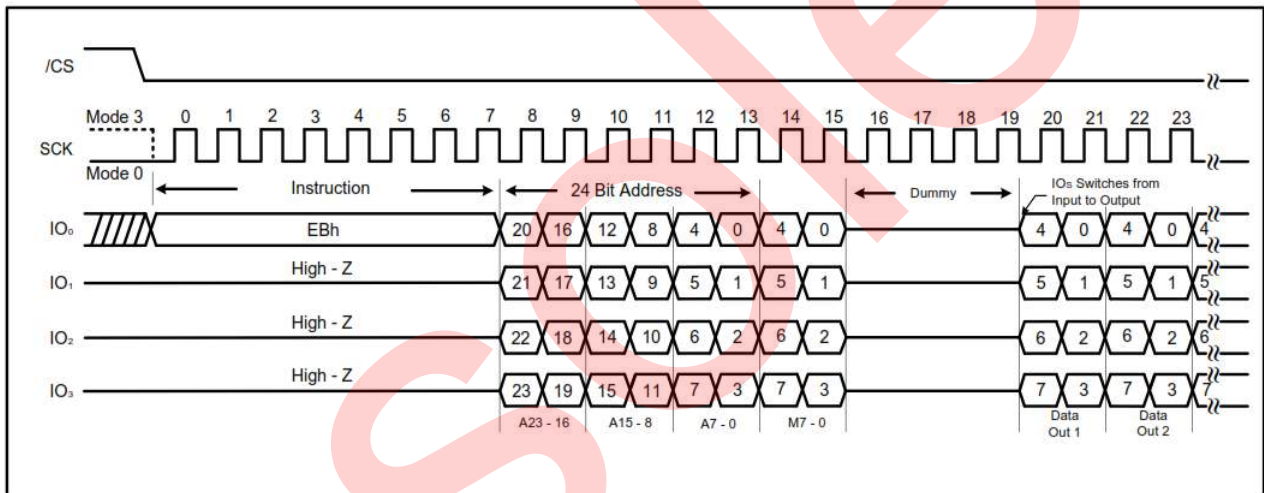
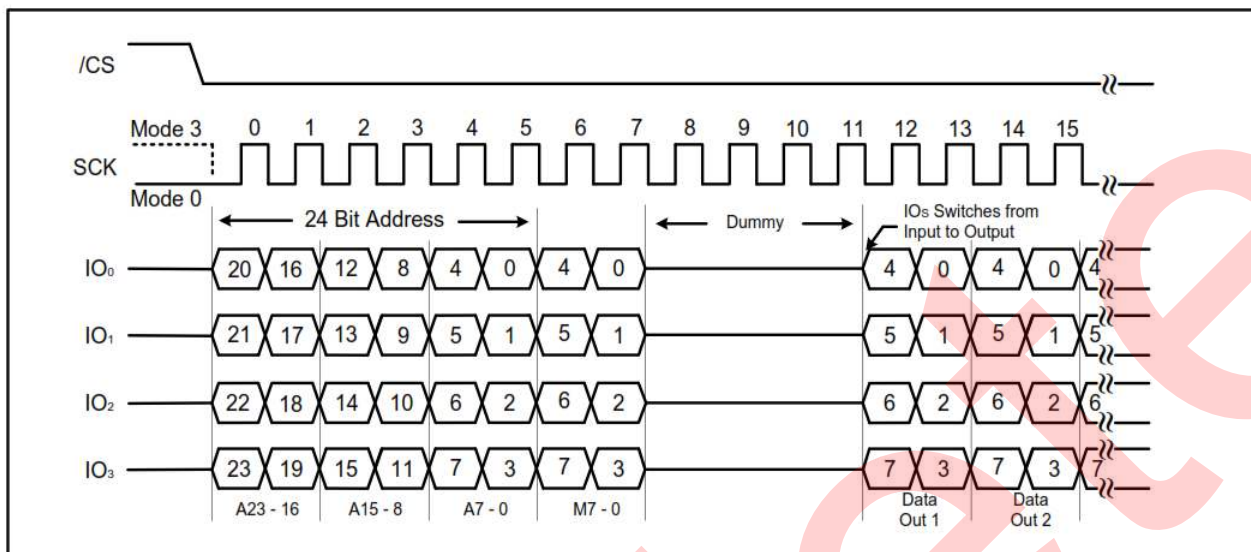

Figure 7-19. Fast Read Quad I/O Instruction (previous M7-0 = Axh, SPI mode)



Wrap Around in SPI mode

The Fast Read Quad I/O instruction can also be used to access specific portion within a page by issuing a Set Burst with Wrap (77h) instruction prior Fast Read Quad I/O (EBh) instruction. The Set Burst with Wrap (77h) instruction can either enable or disable the “Wrap Around” feature for the following Fast Read Quad I/O instruction.

When ‘Wrap Around’ is enabled, the data being accessed can be limited to an 8/16/32/64-byte section of a 256-byte page. The output data starts at the initial address specified in the instruction, once it reaches the ending boundary of the 8/16/32/64-byte section, the output will wrap around to the beginning boundary automatically until \overline{CS} is pulled high to terminate the instruction.

The Burst with Wrap feature allows applications that use cache to quickly fetch a critical address and then fill the cache afterwards within a fixed length (8/16/32/64-byte) of data without issuing multiple read instructions. Please refer to [Section 7.32, Set Burst with Wrap \(77h\)](#).

Fast Read Quad I/O in QPI mode

When QPI mode is enabled, the number of dummy clocks are configured by the Set Read Parameters (C0h) instruction to accommodate a wide range applications with different needs for either maximum Fast Read frequency or minimum data access latency. Depending on the Read Parameter Bits P[4] and P[5] setting, the number of dummy clocks can be configured as either 4, 6, or 8. The default number of dummy clocks upon power up or after a Reset (99h) instruction is 4.

The Continuous Read Mode feature is also available in QPI mode for Fast Read Quad I/O instruction. In QPI mode, the Continuous Read Mode bits M7-0 are also considered as dummy clocks. In the default setting, the data output follows the Continuous Read Mode bits immediately.

The ‘Wrap Around’ feature is not available in QPI mode for the Fast Read Quad I/O instruction. To perform a read operation with a fixed data length wrap around in QPI mode, a Burst Read with Wrap (0Ch) instruction must be used. Please refer to [Section 7.33, Burst Read with Wrap \(0Ch\)](#).

Figure 7-20. Fast Read Quad I/O Instruction (Initial instruction or previous M7-0 ≠ Axx, QPI mode, 80 MHz)

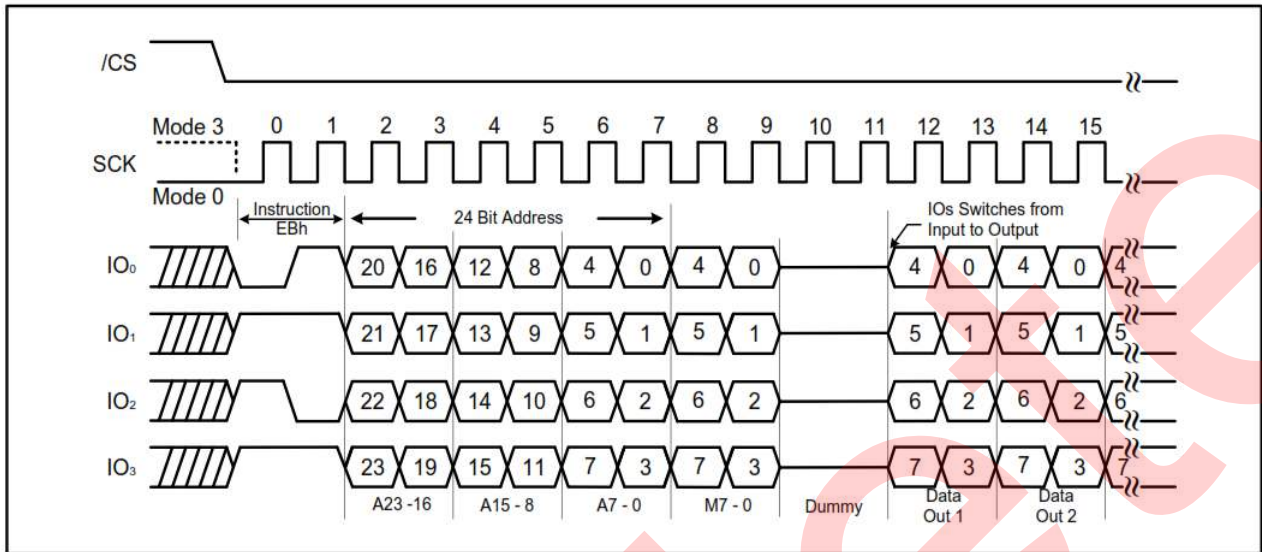
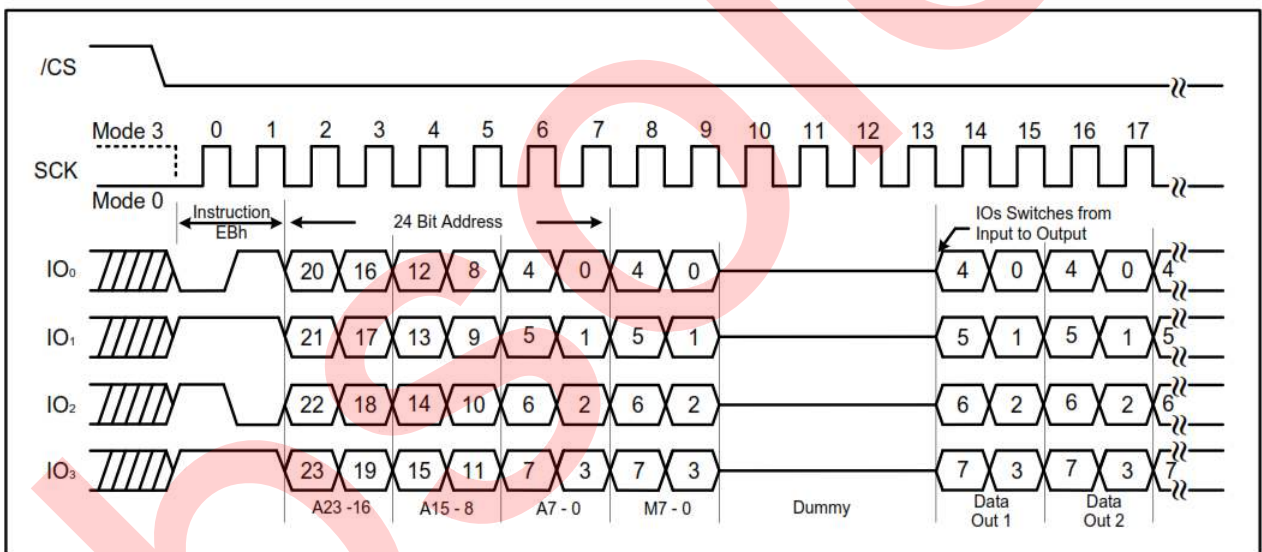

Figure 7-21. Fast Read Quad I/O Instruction (Initial instruction or previous M7-0 ≠ Axx, QPI mode, 104 MHz)



7.15 Page Program (02h)

The Page Program instruction is for programming the memory to be '0'. A Write Enable (06h) instruction must be issued before the device can accept the Page Program Instruction (Status Register bit WEL = 1). After the Write Enable (WREN) instruction has been decoded, hardware sets the Write Enable Latch (WEL).

The instruction is executed by driving the \overline{CS} pin low and then driving the instruction code 02h followed by a 24-bit address (A23-A0) and at least one data byte, onto the SI pin. The \overline{CS} pin must be driven low for the entire time of the instruction while data is being sent to the device. Please refer to [Figure 7-22](#) and [Figure 7-23](#).

If an entire 256-byte page is to be programmed, the last address byte (the 8 least significant address bits) should be set to 0. If the last address byte is not zero, and the number of clocks exceeds the remaining page length, the addressing wraps to the beginning of the page. In some cases, less than 256 bytes (a partial page) can be programmed without having any effect on other bytes within the same page. One condition to perform a partial page program is that the

number of clocks cannot exceed the remaining page length. If more than 256 bytes are sent to the device the addressing will wrap to the beginning of the page and overwrite previously sent data

The \overline{CS} pin must be driven high after the eighth bit of the last byte has been latched. If this is not done the Page Program instruction will not be executed. After \overline{CS} is driven high, the self-timed Page Program instruction will commence for a time duration of t_{pp} . See [Section 8.7, AC Electrical Characteristics](#).

While the Page Program cycle is in progress, the Read Status Register instruction can still be accessed for checking the status of the BUSY bit. The BUSY bit is a 1 during the Page Program cycle and becomes a 0 when the cycle is finished and the device is again ready to accept other instructions. When the BUSY bit is asserted, hardware clears the Write Enable Latch (WEL) bit in the Status Register to 0. The Page Program instruction is not executed if the addressed page is protected by the Protect (CMP, SEC, TB, BP2, BP1 and BP0) bits.

Figure 7-22. Page Program Instruction (SPI Mode)

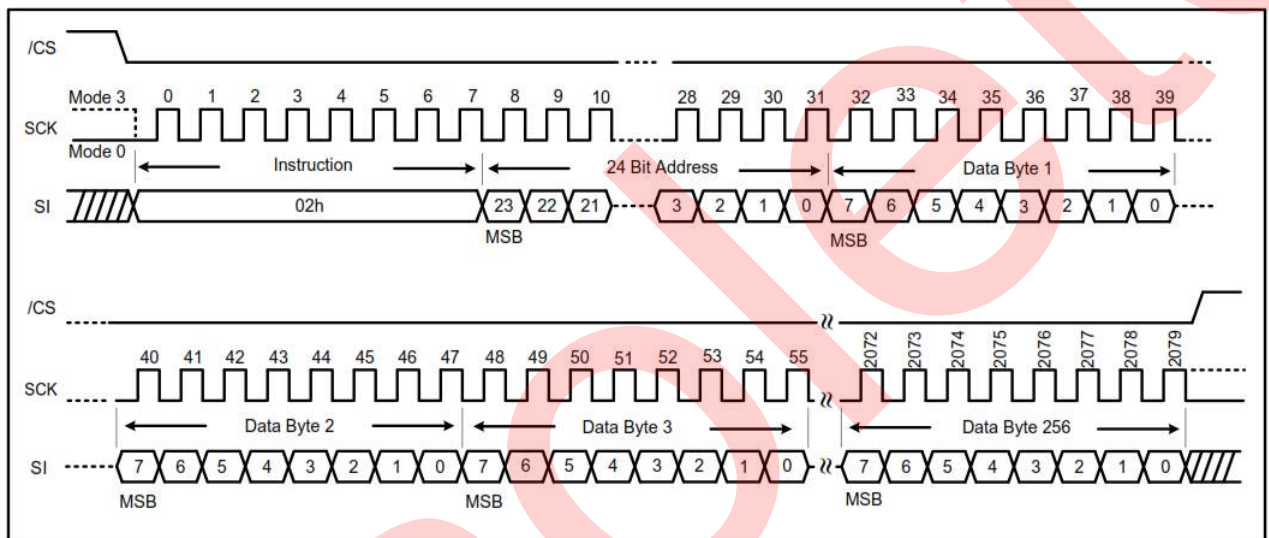
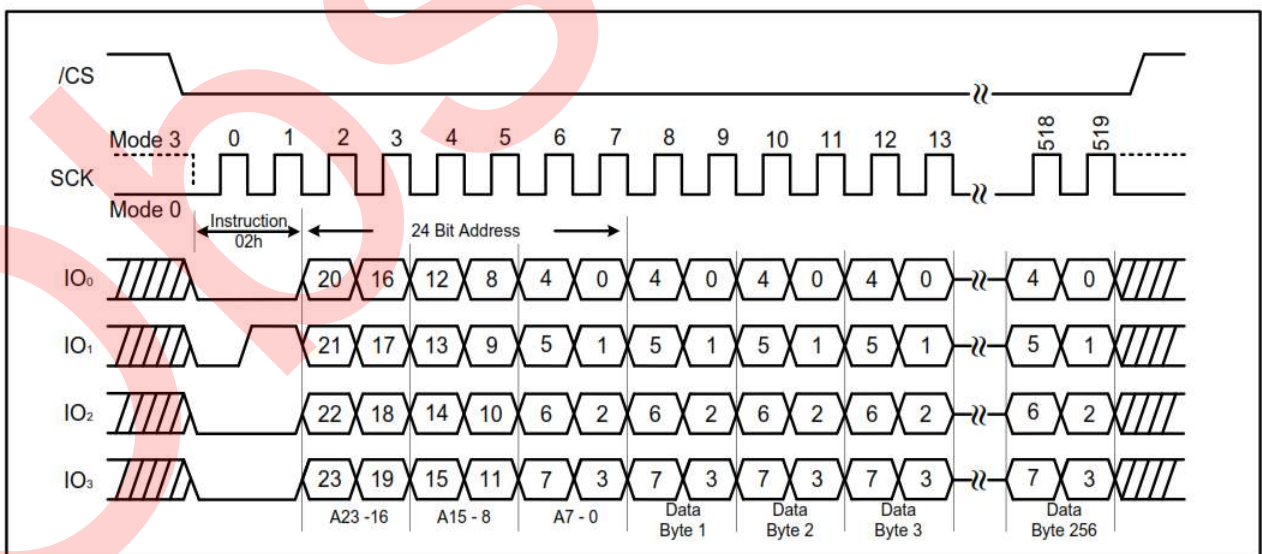

Figure 7-23. Page Program Instruction (QPI Mode)



7.16 Quad Page Program (33h)

The Quad Page Program instruction is to program the memory as being “0” at previously erased memory areas. The Quad Page Program takes four pins: IO₀, IO₁, IO₂ and IO₃ as address and data input, which can improve programmer performance and the effectiveness of application of lower clock less than 5 MHz. Systems using faster clock speeds will not get more benefit for the Quad Page Program as the required internal page program time is far more than the time data clock-in.

To use Quad Page Program, the Quad Enable bit must be set, A Write Enable instruction must be executed before the device can accept the Quad Page Program instruction (Status Register-1, WEL = 1). In SPI mode, the instruction is initiated by driving the \overline{CS} pin low then driving the instruction code 33h onto the SI pin. This is followed by a 24-bit address (A23-A0) and at least one byte of data onto the four IO pins. The \overline{CS} pin must be held low for the entire length of the instruction while data is being sent to the device. All other functions of Quad Page Program are perfectly same as standard Page Program.

In QPI mode, the transfer mechanism is similar to SPI mode, except that the instruction is sent on all four I/O pins instead of just the SI pin. This allows the instruction to be transferred in two clocks instead of eight.

Please refer to [Figure 7-24](#) and [Figure 7-25](#).

Figure 7-24. Quad Page Program Instruction (SPI mode)

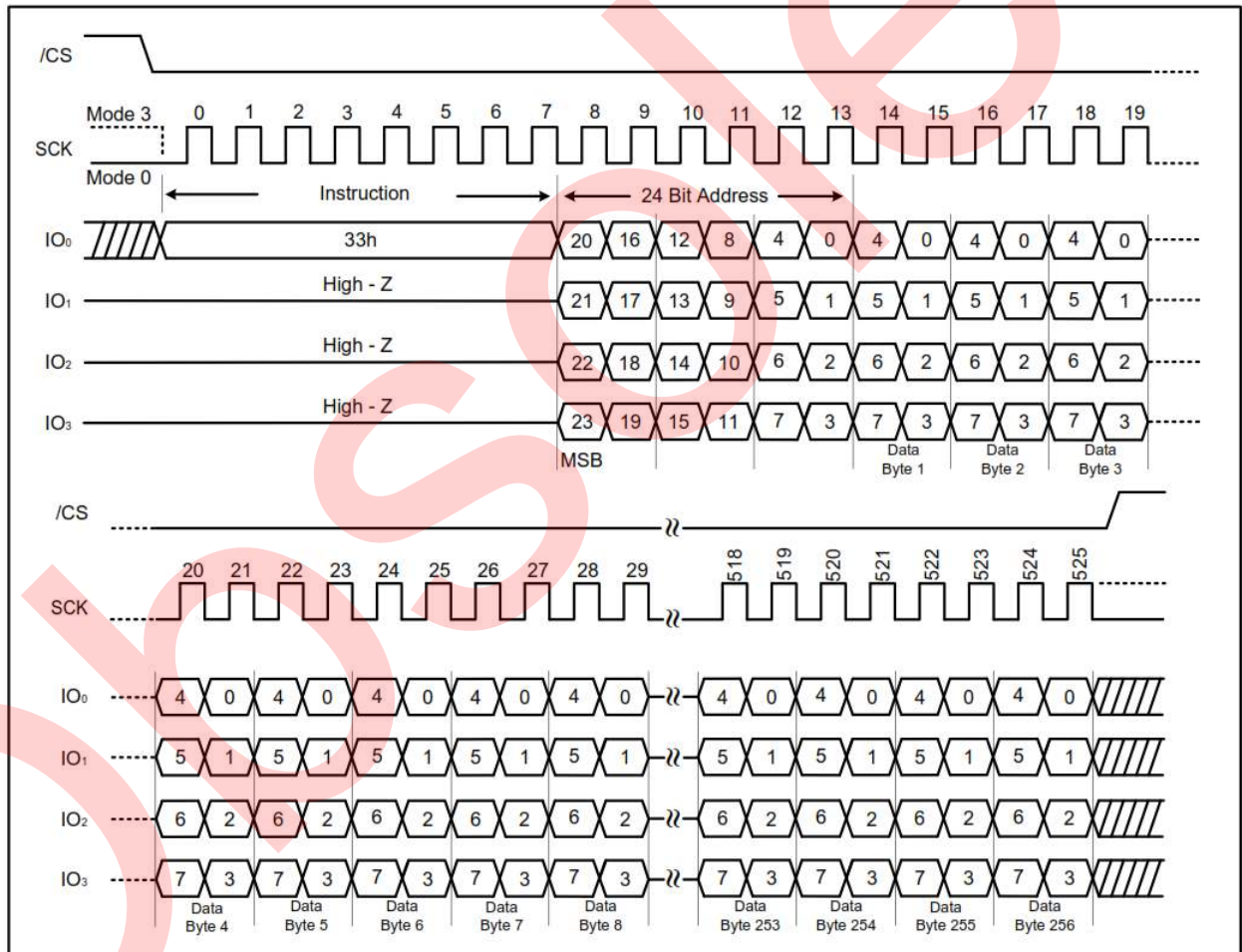
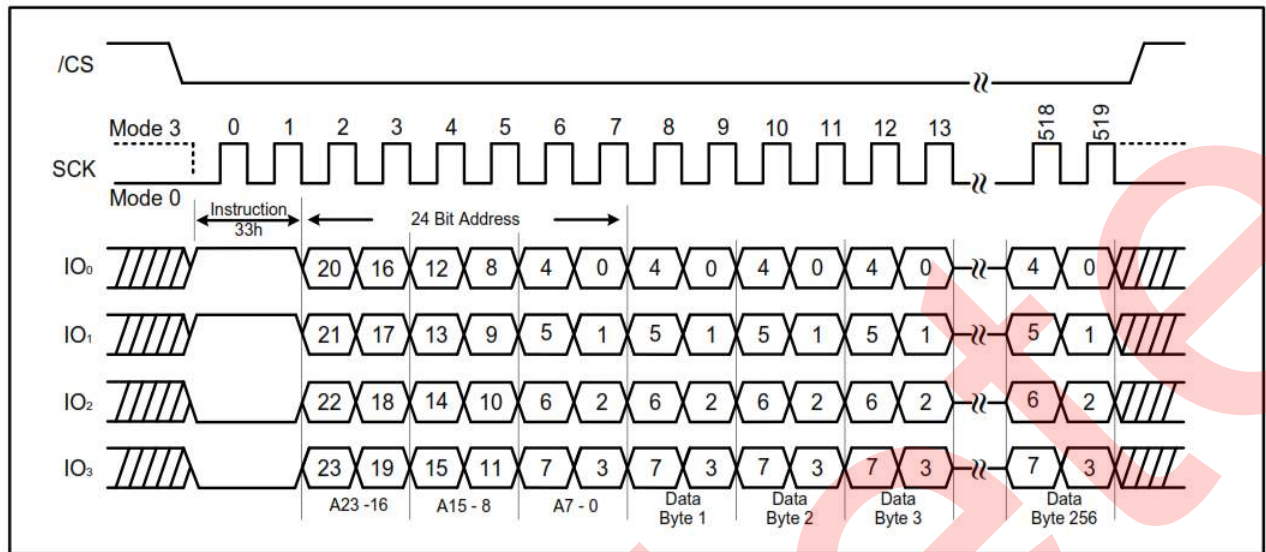

Figure 7-25. Quad Page Program Instruction (QPI mode)



7.17 Block Erase (20h)

The Block Erase instruction is to erase the data of the selected sector as being '1'. The instruction is used to erase a 4 Kbyte Block. Prior to the Block Erase Instruction, the Write Enable (06h) instruction must be issued. The instruction is initiated by driving the $\overline{\text{CS}}$ pin low and shifting the instruction code 20h, followed by a 24-bit Block address (A23-A0). The 8-bit instruction code can require either eight clocks or two clocks to transfer depending on the operating mode. Please refer to [Figure 7-26](#) for SPI mode and [Figure 7-27](#) for QPI mode.

The $\overline{\text{CS}}$ pin must go high after the eighth bit of the last byte has been latched in. Otherwise the Block Erase instruction is not executed. After $\overline{\text{CS}}$ goes high, the self-timed Block Erase instruction commences for a time duration of t_{SE} . See [Section 8.7, AC Electrical Characteristics](#).

While the Block Erase cycle is in progress, the Read Status Register instruction can still be accessed for checking the status of the BUSY bit. The BUSY bit is a 1 during the Block Erase cycle and becomes a 0 when the cycle is finished and the device is ready to accept other instructions again. When the BUSY bit is asserted, the Write Enable Latch (WEL) bit in the Status Register is cleared to 0. The Block Erase instruction is not executed if the addressed page is protected by the Protect (CMP, SEC, TB, BP2, BP1 and BP0) bits.

Figure 7-26. Block Erase Instruction (SPI Mode)

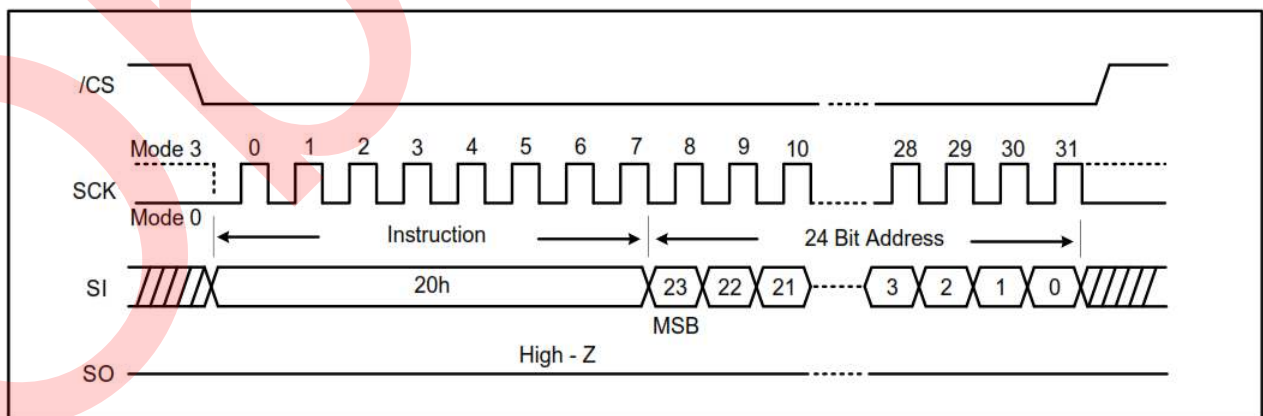
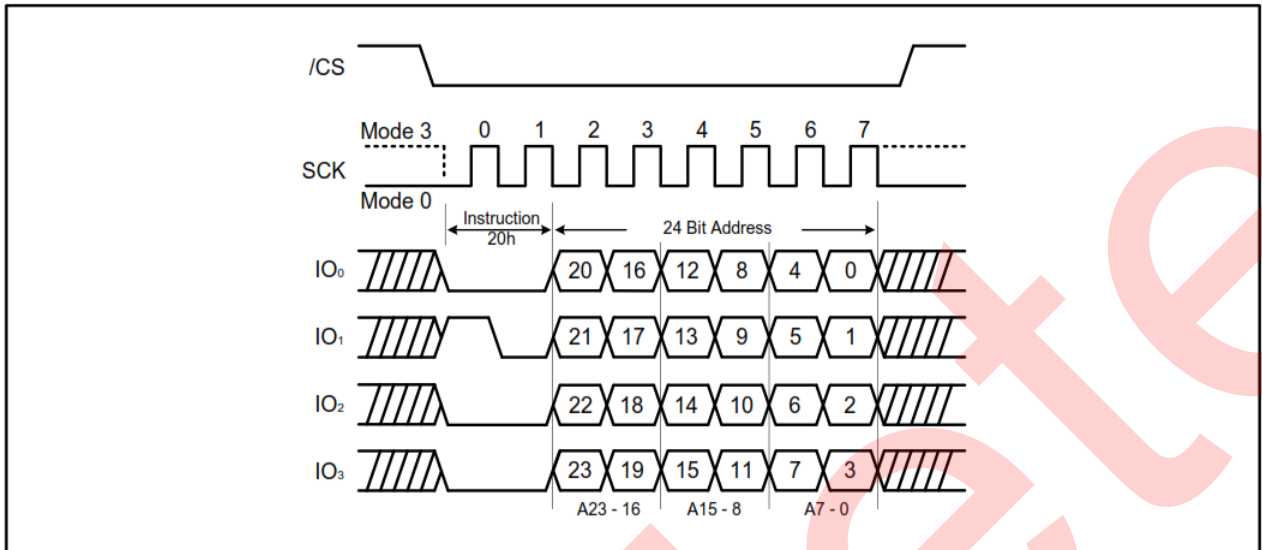

Figure 7-27. Block Erase Instruction (QPI Mode)



7.18 32 KB Block Erase (52h)

This instruction is used for to perform a 32 Kbyte block erase operation. Prior to the Block Erase Instruction, a Write Enable (06h) instruction must be issued. The instruction is initiated by driving the \overline{CS} pin low and shifting the instruction code 52h, followed by a 24-bit block address (A23-A0). The 8-bit instruction code can require either eight clocks or two clocks to transfer depending on the operating mode. Please refer to [Figure 7-28](#) for SPI mode and [Figure 7-29](#) for QPI mode.

The \overline{CS} pin must go high after the eighth bit of the last byte has been latched in, otherwise, the Block Erase instruction will not be executed. After \overline{CS} is driven high, the self-timed Block Erase instruction commences for a time duration of t_{BE1} (See [Section 8.7, AC Electrical Characteristics](#)).

While the Block Erase cycle is in progress, the Read Status Register instruction can still be read the status of the BUSY bit. The BUSY bit is a 1 during the Block Erase cycle and becomes a 0 when the cycle is finished and the device is ready to accept other instructions again. When the BUSY bit is asserted, the Write Enable Latch (WEL) bit in the Status Register is cleared to 0. The Block erase instruction is not executed if the addressed page is protected by the Protect (CMP, SEC, TB, BP2, BP1 and BP0) bits.

Figure 7-28. 32 KB Block Erase Instruction (SPI Mode)

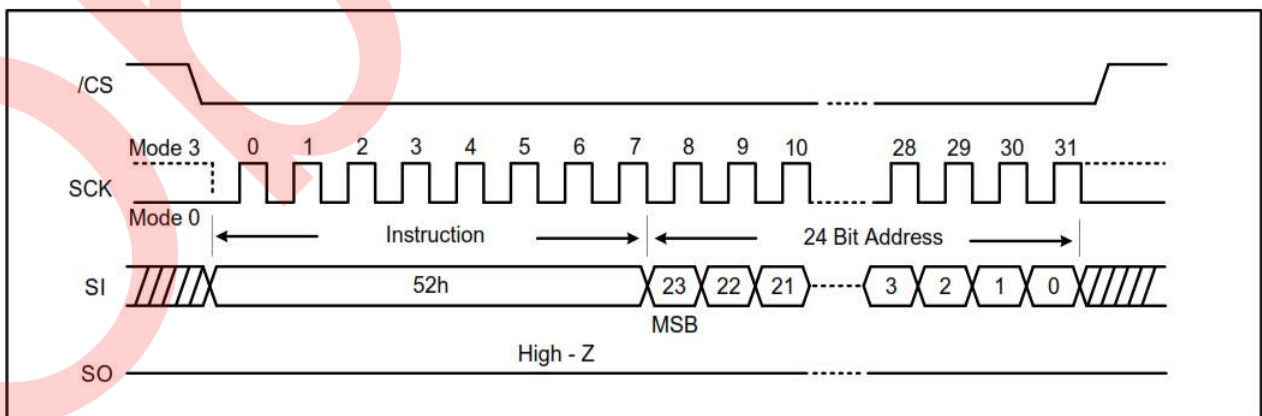
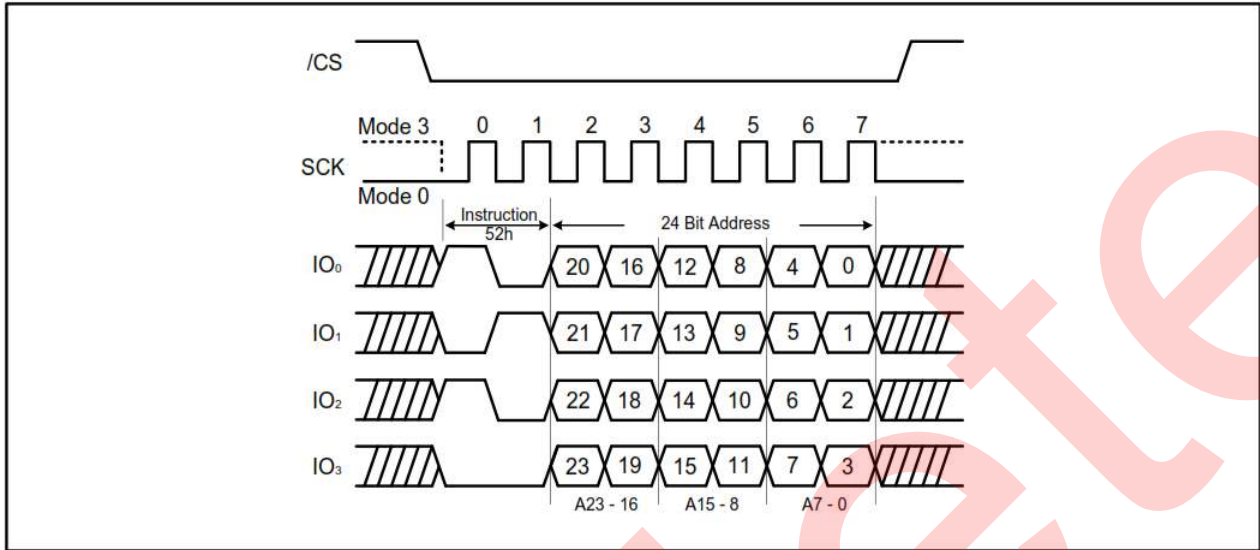

Figure 7-29. 32 KB Block Erase Instruction (QPI Mode)



7.19 64KB Block Erase (D8h)

The Block Erase instruction is to erase the data of the selected block as being "1". The instruction is used for 64K-byte Block erase operation. Prior to the Block Erase Instruction, a Write Enable instruction must be issued. The instruction is initiated by driving the \overline{CS} pin low and shifting the instruction code "D8h" followed a 24-bit block address (A23-A0). The 8-bit instruction code can require either eight clocks or two clocks to transfer depending on the operating mode. Please refer to [Figure 7-30](#) for SPI mode and [Figure 7-31](#) for QPI mode).

The \overline{CS} pin must go high after the eighth bit of the last byte has been latched in, otherwise, the Block Erase instruction will not be executed. After \overline{CS} is driven high, the self-timed Block Erase instruction commences for a time duration of t_{BE2} . See [Section 8.7, AC Electrical Characteristics](#).

While the Block Erase cycle is in progress, the Read Status Register instruction can still be read the status of the BUSY bit. The BUSY bit is a 1 during the Block Erase cycle and becomes a 0 when the cycle is finished and the device is ready to accept other instructions again. When the BUSY bit is asserted, the Write Enable Latch (WEL) bit in the Status Register is cleared to 0. The Block erase instruction will not be executed if the addressed page is protected by the Protect (CMP, SEC, TB, BP2, BP1 and BP0) bits.

Figure 7-30. 64 KB Block Erase Instruction (SPI Mode)

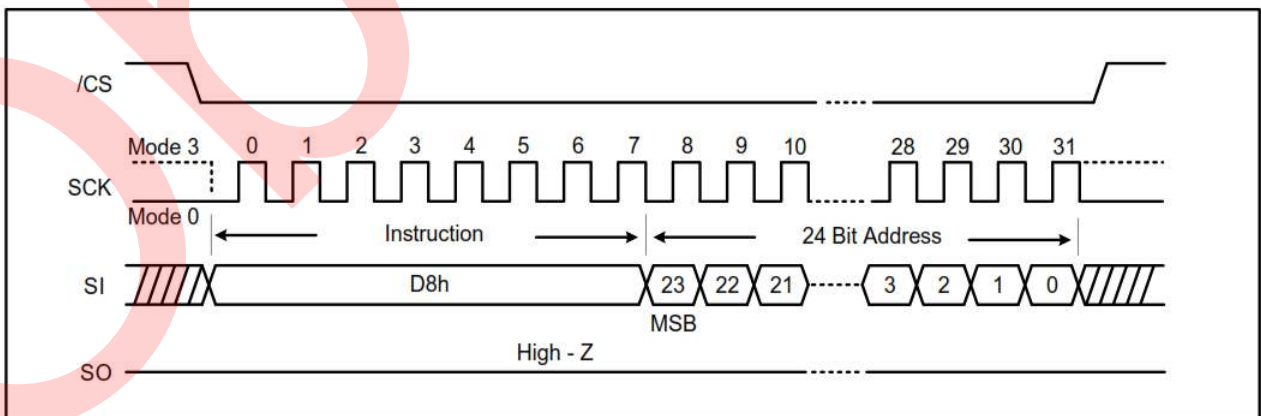
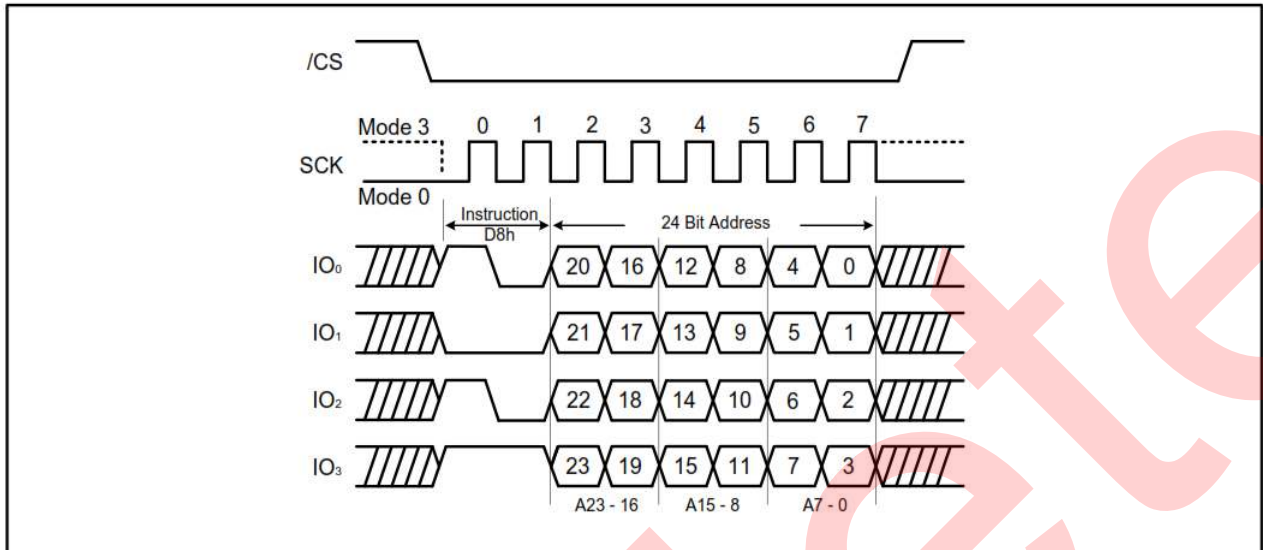

Figure 7-31. 64 KB Block Erase Instruction (QPI Mode)



7.20 Chip Erase (C7h / 60h)

The Chip Erase instruction clears all bits in the device to be FFh (all 1s). Prior to the Chip Erase Instruction, a Write Enable instruction must be issued. The instruction is initiated by driving the \overline{CS} pin low and shifting the instruction code C7h or 60h. The 8-bit instruction code can require either eight clocks or two clocks to transfer depending on the operating mode. Please refer to [Figure 7-32](#). The \overline{CS} pin must go high after the eighth bit of the last byte has been latched in, otherwise, the Chip Erase instruction is not executed. After \overline{CS} is driven high, the self-timed Chip Erase instruction commences for a duration of t_{CE} . Refer to [Section 8.7, AC Electrical Characteristics](#).

While the Chip Erase cycle is in progress, the Read Status Register instruction can still be accessed to check the status of the BUSY bit. The BUSY bit is a 1 during the Chip Erase cycle and becomes a 0 when the cycle is finished and the device is ready to accept other instructions again. When the BUSY bit is asserted, the Write Enable Latch (WEL) bit in the Status Register is cleared to 0. The Chip erase instruction is not executed if any page is protected by the Protect (CMP, SEC, TB, BP2, BP1 and BP0) bits.

Figure 7-32. Chip Erase Instruction for SPI Mode (left) and QPI Mode (right)

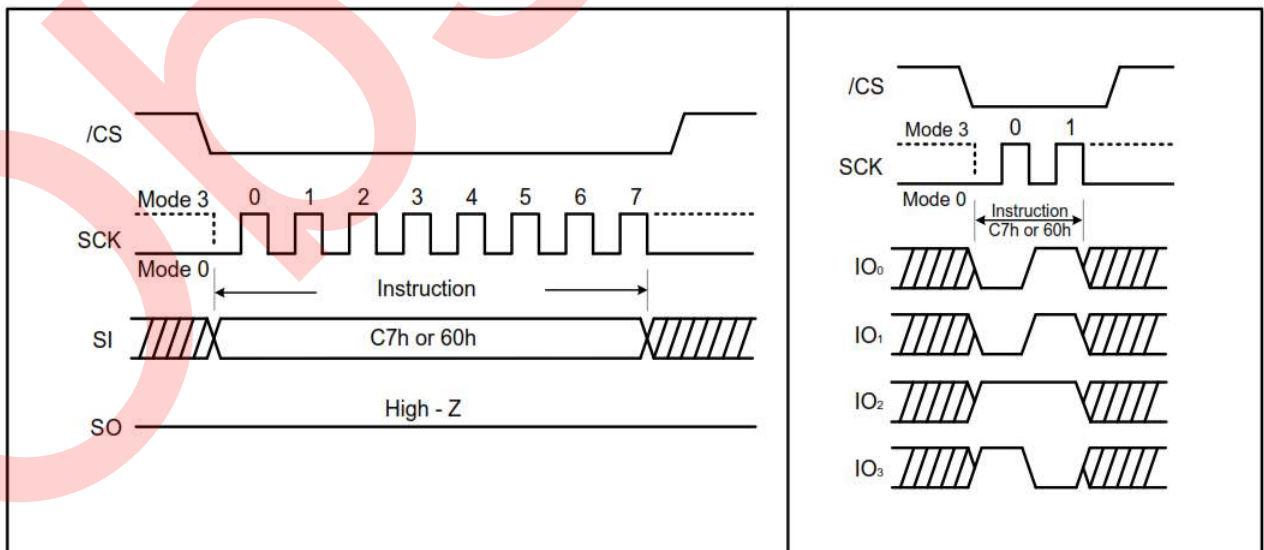

7.21 Erase / Program Suspend (75h)

The Erase/Program Suspend instruction allows the system to interrupt a Block Erase operation or a Page Program, Quad Data Input Page Program, Quad Page Program operation.

Erase Suspend is valid only during the Block erase operation. The Write Status Register-1 (01h), Write Status Register-2 (31h) instruction and Erase instructions (20h, 52h, D8h, C7h, 60h) are not allowed during Erase Suspend. During the Chip Erase operation, the Erase Suspend instruction is ignored.

Program Suspend is valid only during the Page Program, Quad Data Input Page Program or Quad Page Program operation. The Write Status Register-1 (01h), Write Status Register-2 (31h) instruction and Program instructions (02h and 33h) and Erase instructions (20h, 52h, D8h, C7h, and 60h) are not allowed during Program Suspend.

The Erase/Program Suspend instruction 75h is accepted by the device only if the SUS bit in the Status Register equals 0 and the BUSY bit equals 1 while a Block Erase or a Page Program operation is on-going. If the SUS bit equals 1 or the BUSY bit equals 0, the Suspend instruction is ignored by the device. A maximum of time of t_{SUS} is required to suspend the erase or program operation. Refer to [Section 8.7, AC Electrical Characteristics](#).

After Erase/Program Suspend, the SUS bit in the Status Register changes from 0 to 1 immediately and the BUSY bit in the Status Register is cleared from 1 to 0 within t_{SUS} . For a previously resumed Erase/Program operation, it is also required that the Suspend instruction 75h is not issued earlier than a minimum of time of t_{SUS} following the preceding Resume instruction 7Ah.

Unexpected power off during the Erase/Program suspend state resets the device and release the suspend state. SUS bit in the Status Register also resets to 0. The data within the page or block that was being suspended may become corrupted. It is recommended for the user to implement system design techniques against the accidental power interruption and preserve data integrity during erase/program suspend state. Please refer to [Figure 7-33](#) and [Figure 7-34](#).

Figure 7-33. Erase Suspend Instruction (SPI Mode)

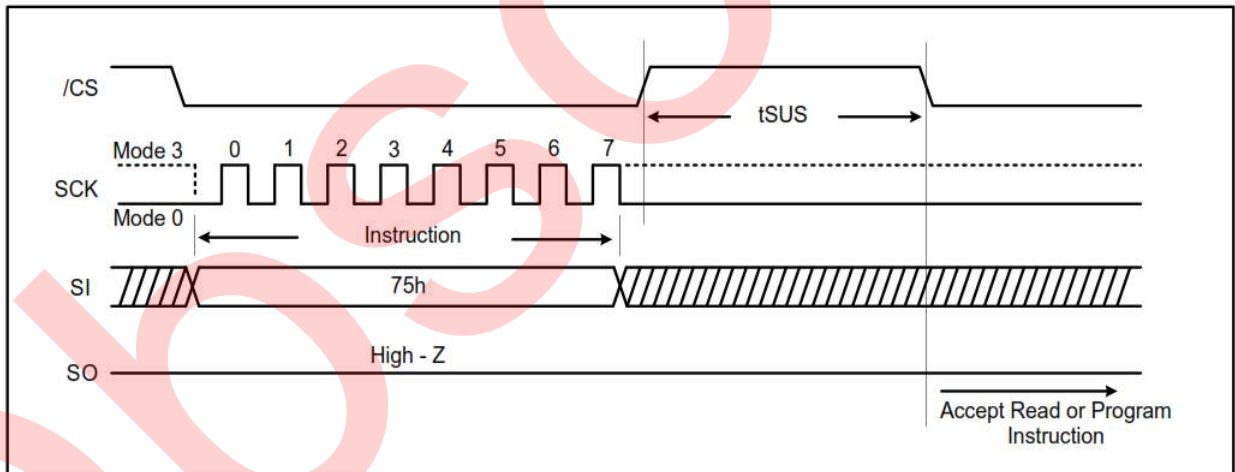
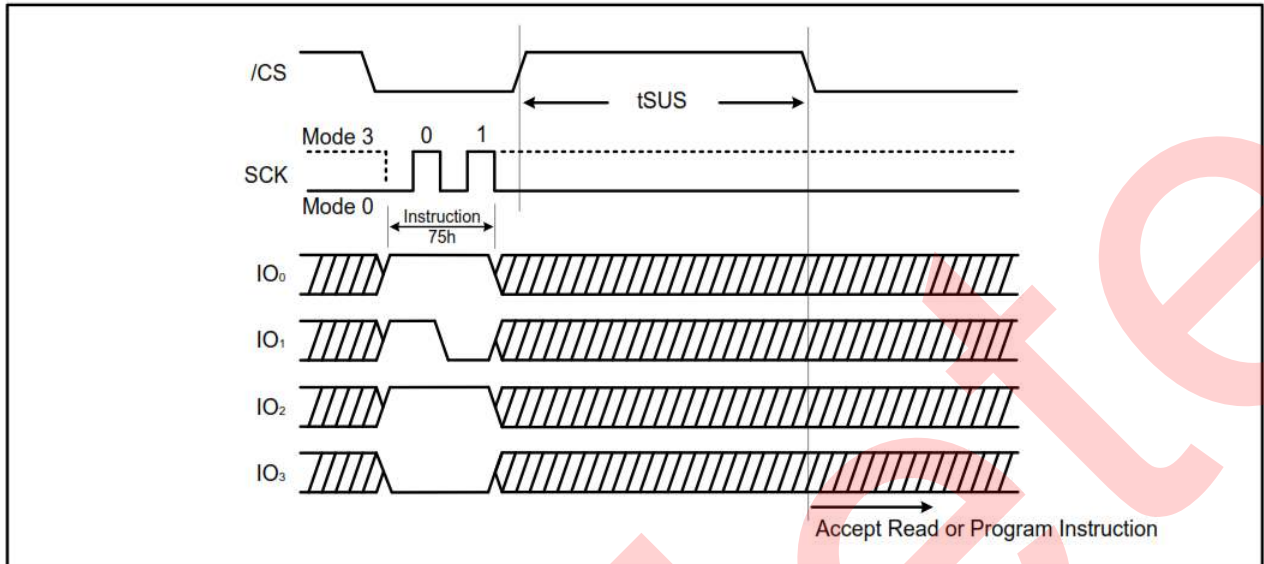

Figure 7-34. Erase Suspend Instruction (QPI Mode)



7.22 Erase / Program Resume (7Ah)

The Erase/Program Resume instruction 7Ah is to re-work the Block Erase operation or the Page Program operation upon an Erase/Program Suspend. The Resume instruction 7Ah is accepted by the device only if the SUS bit in the Status Register equals 1 and the BUSY bit equals 0. After issue, the SUS bit is cleared from 1 to 0 immediately, the BUSY bit changes from 0 to 1 within 200ns and the block will complete the erase operation or the page will complete the program operation. If the SUS bit equals 0 or the BUSY bit equals 1, the Resume instruction 7Ah will be ignored by the device.

Resume instruction cannot be accepted if the previous Erase/Program Suspend operation was interrupted by unexpected power off. It is also required that a subsequent Erase/Program Suspend instruction not to be issued within a minimum of time of t_{SUS} following a previous Resume instruction. Please refer to [Figure 7-35](#) and [Figure 7-36](#)

Figure 7-35. Erase / Program Resume instruction (SPI Mode)

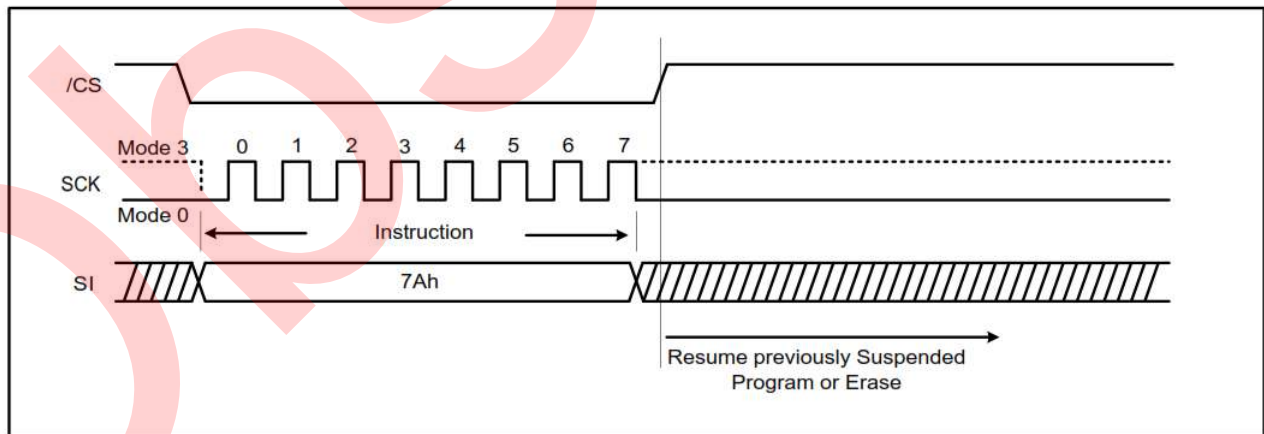
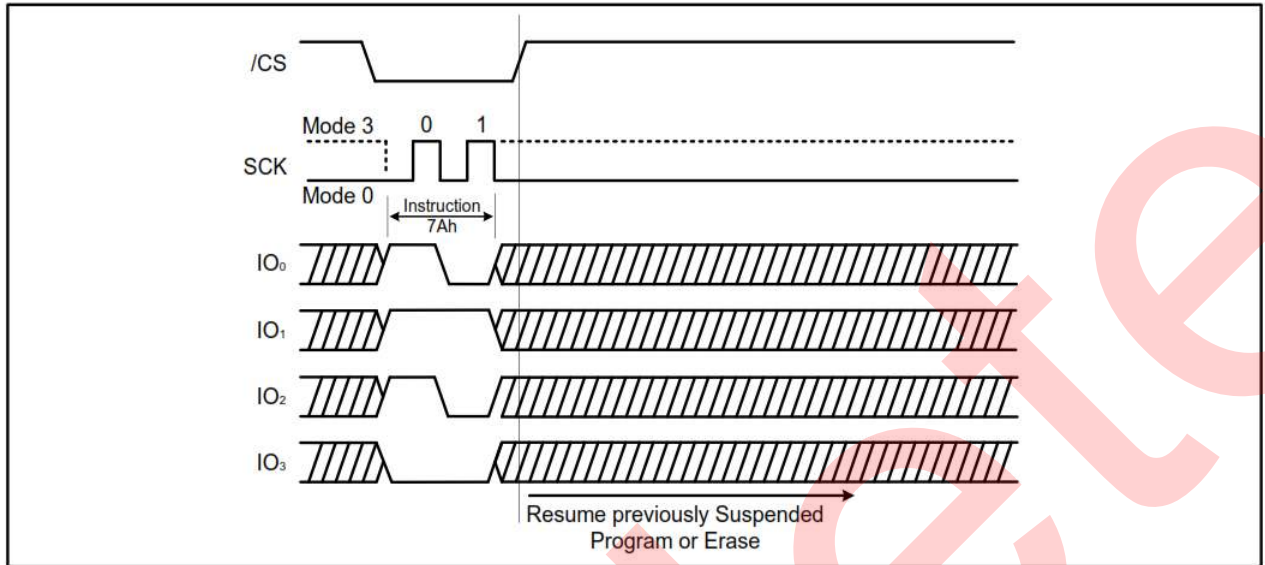

Figure 7-36. Erase / Program Resume instruction (QPI Mode)



7.23 Deep Power Down (B9h)

Executing the Deep Power Down (DPD) instruction is the best way to put the device in the lowest power consumption. The Deep Power Down instruction reduces the standby current (from ICC1 to ICC2, as specified in [Section 8.7, AC Electrical Characteristics](#)). The instruction is entered by driving the \overline{CS} pin low with following the instruction code B9h. Please refer to [Figure 7-37](#) and [Figure 7-38](#).

The \overline{CS} pin must go high exactly at the byte boundary (the latest eighth bit of instruction code been latched-in); otherwise, the Deep Power Down instruction is not executed. After \overline{CS} goes high, it requires a delay of t_{DP} and the Deep Power Down mode is entered.

While in DPD mode, only the Release Deep Power Down / Device ID instruction, which restores the device to normal operation, is recognized. All other instructions are ignored including the Read Status Register instruction, which is always available during normal operation. Deep Power Down (DPD) mode automatically stops at Power-Down, and the device always powers up in the Standby Mode.

Figure 7-37. Deep Power Down Instruction (SPI Mode)

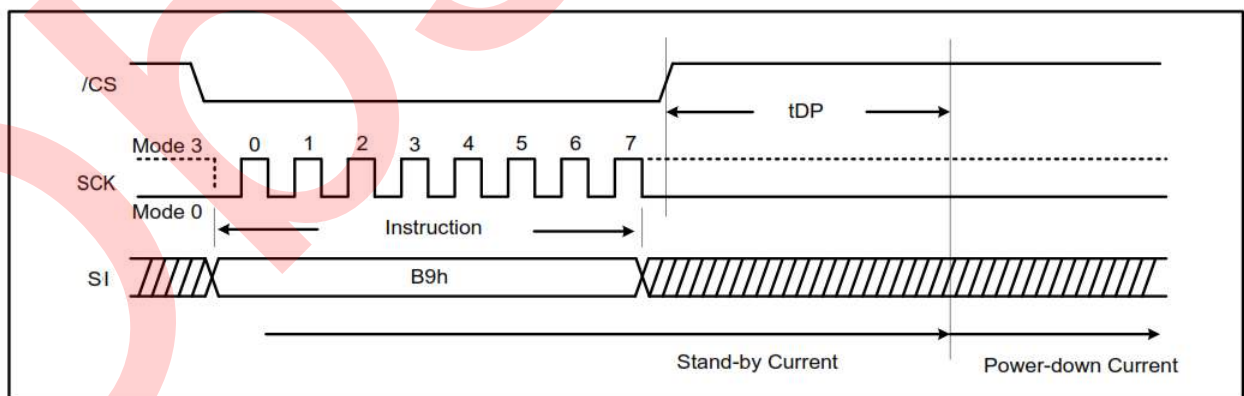
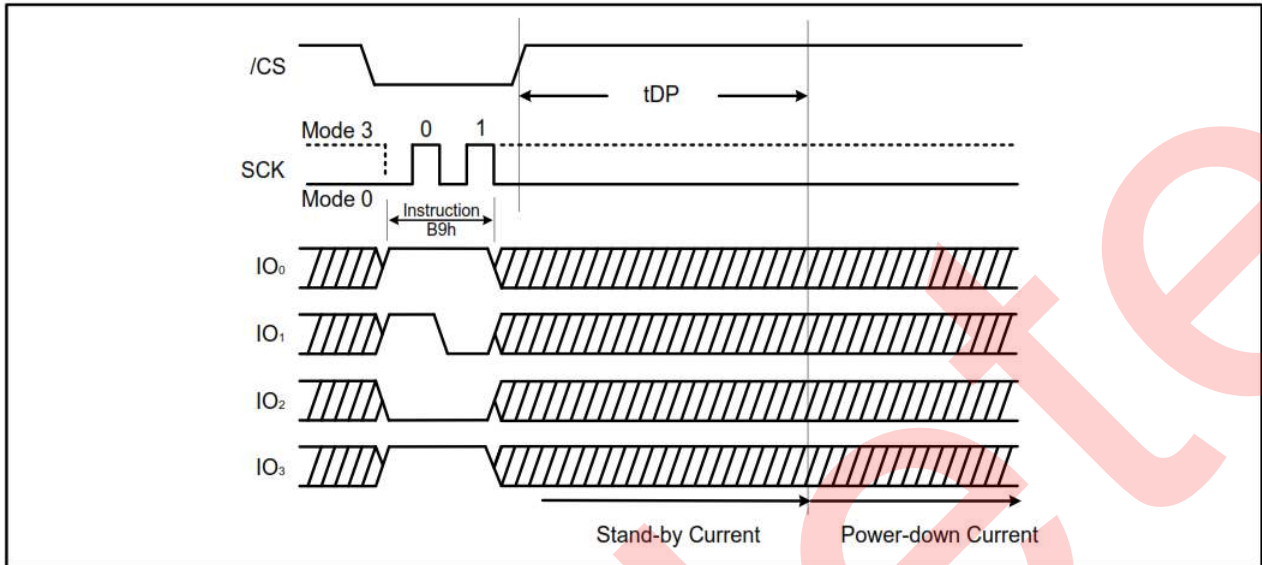

Figure 7-38. Deep Power Down Instruction (QPI Mode)



7.24 Release Deep Power Down / Device ID (ABh)

The Release Deep Power Down / Device ID instruction is a multi-purpose instruction. It can be used to release the device from the Deep Power Down state or obtain the device identification (ID).

The instruction is issued by driving the \overline{CS} pin low, sending the instruction code ABh and driving \overline{CS} high as shown in Figure 7-39 and Figure 7-40. The Release from Deep Power Down instruction requires the time duration of t_{RES1} as described in Section 8.7, AC Electrical Characteristics. The \overline{CS} pin must keep high during the t_{RES1} time duration.

The Device ID can be read during SPI mode only. In other words, Device ID feature is not available in QPI mode for Release Deep Power Down/Device ID instruction. To obtain the Device ID in SPI mode, instruction is initiated by driving the \overline{CS} pin low and sending the instruction code "ABh" with following 3-dummy bytes. The Device ID bits are then shifted on the falling edge of SCK with most significant bit (MSB) first as shown in Figure 7-41. After \overline{CS} is driven high it must keep high for a time duration of t_{RES2} as described in Section 8.7, AC Electrical Characteristics. The Device ID can be read continuously. The instruction is completed by driving \overline{CS} high.

If the Release from Deep Power Down /Device ID instruction is issued while an Erase, Program or Write cycle is in process (when BUSY equals 1) the instruction is ignored and does not have any effect on the current cycle.

Figure 7-39. Release Power Down Instruction (SPI Mode)

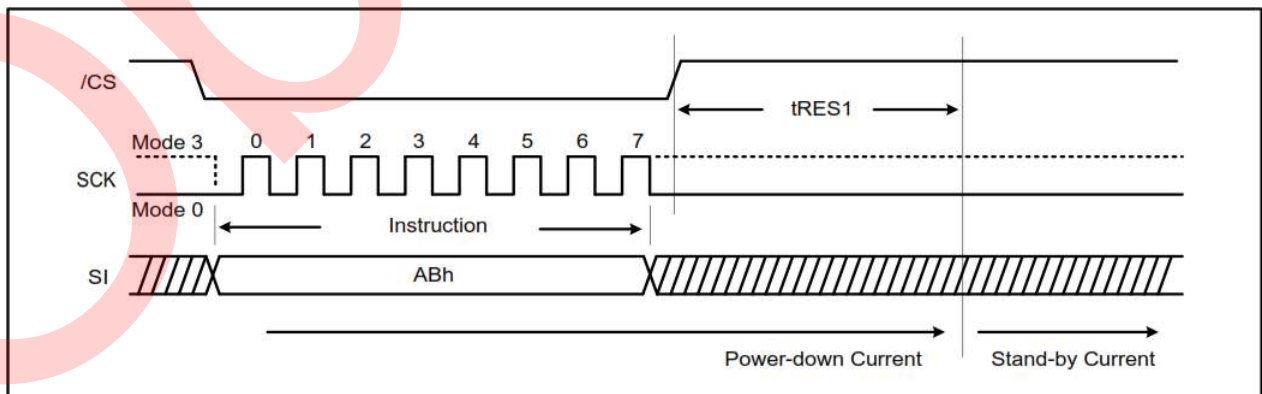

Figure 7-40. Release Power Down Instruction (QPI Mode)

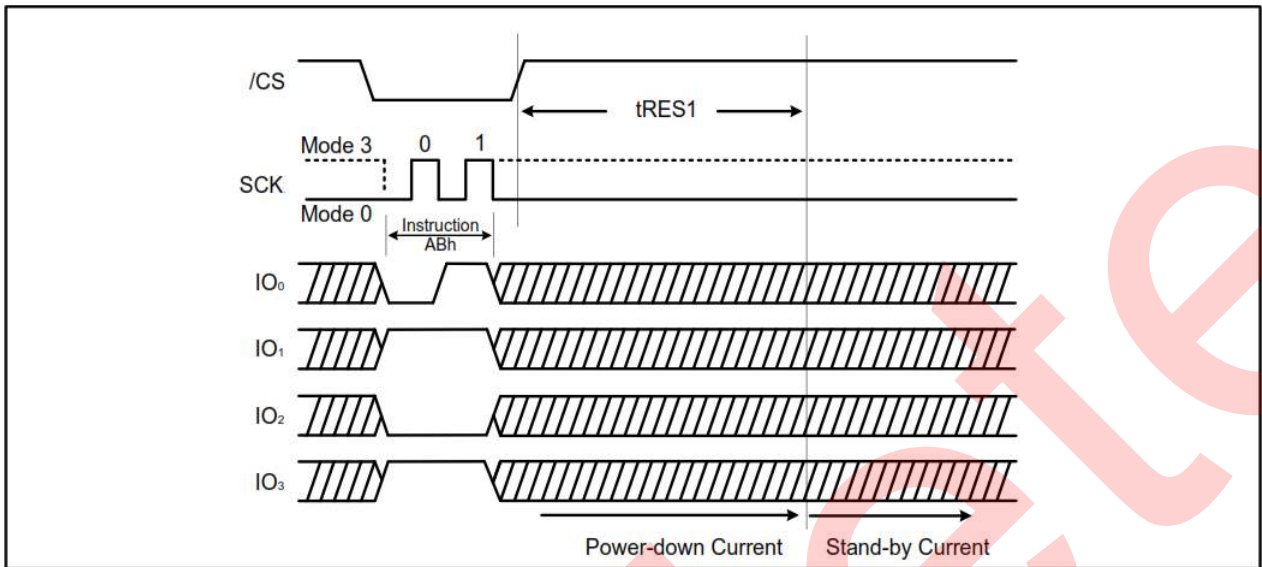
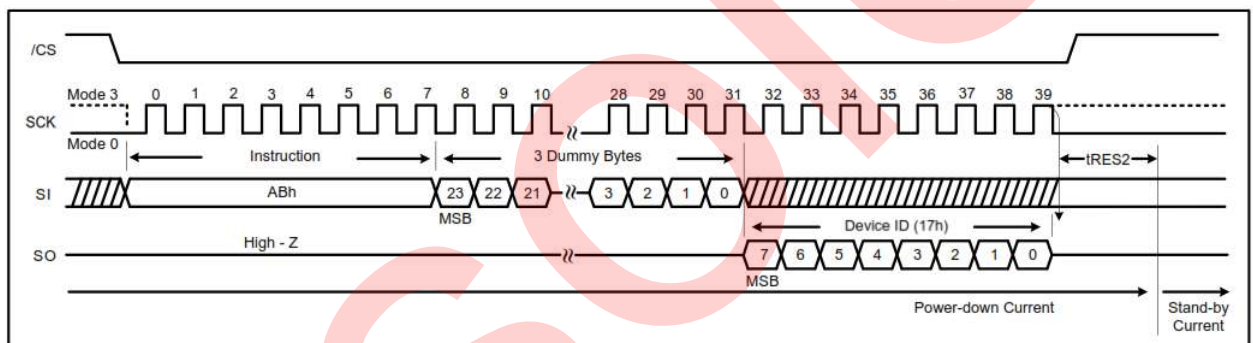

Figure 7-41. Release Power Down / Device ID Instruction (SPI Mode)



7.25 Read Manufacturer / Device ID (90h)

The Read Manufacturer/ Device ID instruction provides both the JEDEC assigned manufacturer ID and the specific device ID. This instruction can be issued in both SPI mode and QPI mode. Note that in QPI mode, the execution of the QPI Enable (38h) instruction must be issued prior to the 90h instruction. The 90h instruction is called a 1,1,1 transfer, where the instruction, address, and data are all driven on a single pin (SI for instruction and address, and SO for data).

In SPI mode, the operation is initiated by driving the \overline{CS} pin low and then driving the instruction code 90h onto the SI pin, followed by a 24-bit address (A₂₃-A₀) of 000000h. The 90h instruction requires 8 clocks to transfer, and the 24-bit address requires 24 clocks to transfer. The Manufacturer ID for Dialog Semiconductor (1Fh) and the Device ID (16h) are shifted out on the SO pin on the falling edge of SCK with most significant bit (MSB) first. A minimum of 16 clocks are required to transfer the manufacturer and device ID information. If the 24-bit address is initially set to 000001h the Device ID is read first and then followed by the Manufacturer ID. The Manufacturer and Device ID can be read continuously, alternating from one to the other. The instruction is completed by driving \overline{CS} high.

In QPI mode, the SI, SO, \overline{WP} , and \overline{HOLD} pins are configured as bidirectional pins IO₀, IO₁, IO₂, and IO₃ respectively. The 90h operation the operation is initiated by driving the \overline{CS} pin low and then driving the instruction code 90h onto the IO₀ - IO₃ pins, followed by a 24-bit address (A₂₃-A₀) of 000000h. The 90h instruction requires 2 clocks to transfer, and the 24-bit address requires 6 clocks to transfer. The Manufacturer ID for Dialog Semiconductor (1Fh) and the Device ID (16h) are shifted out on the bidirectional IO₀ - IO₃ pins on the falling edge of SCK, with most significant bit (MSB) first. A minimum of 4 clocks are required to transfer the manufacturer and device ID information. If the 24-bit

address is initially set to 000001h the Device ID is read first and then followed by the Manufacturer ID. The Manufacturer and Device ID can be read continuously, alternating from one to the other. The instruction is completed by driving \overline{CS} high.

Figure 7-42 shows the 90h command as executed in SPI mode. In this mode the instruction and address are driven on the SI pin.

Figure 7-43 shows the 90h command as executed in QPI mode. In this mode the instruction and address are driven on all four I/O pins.

Figure 7-42. Read Manufacturer/ Device ID Instruction (SPI Mode)

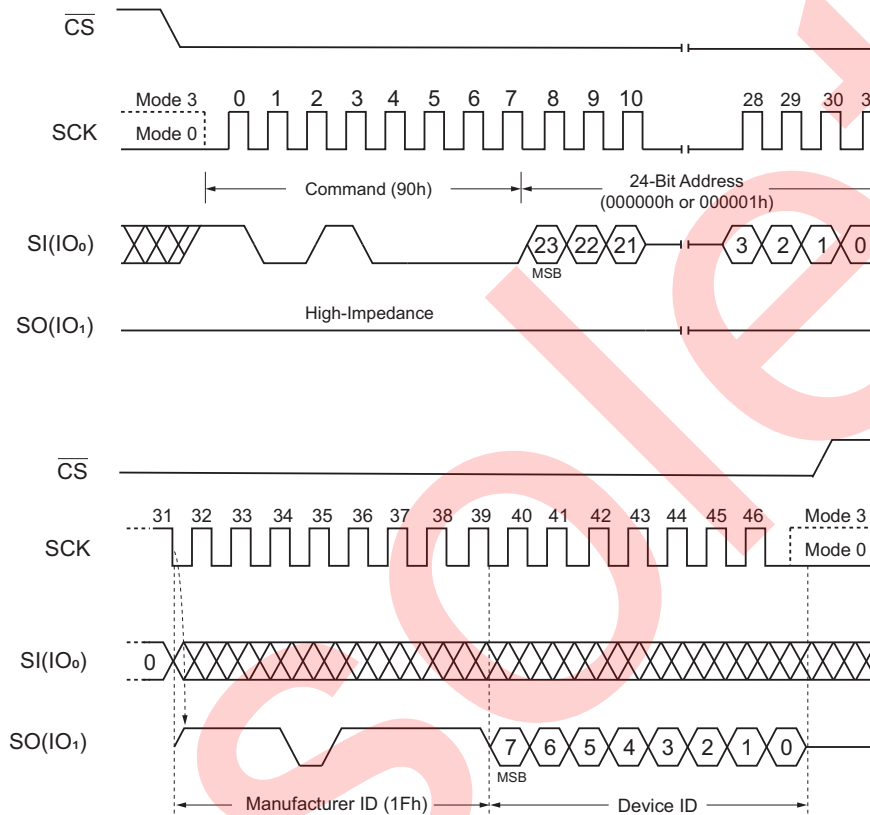
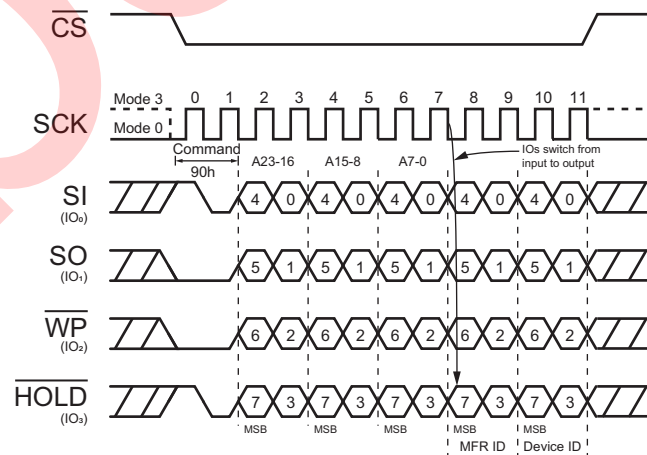

Figure 7-43. Read Manufacturer/ Device ID Instruction (QPI Mode)



7.26 Read Manufacturer / Device ID Dual I/O (92h)

The Read Manufacturer/ Device ID Dual I/O instruction provides both the JEDEC assigned manufacturer ID and the specific device ID. This command allows the address and manufacturer/device ID information to be driven on both the SI and SO pins. During the address transfer, the SI and SO pins are inputs, allowing the 24-bit address to be transferred in only 12 clocks. Device hardware then switches the SI and SO pins to outputs and drives the manufacturer/device ID information on these two pins, again requiring only half the number of clocks as required by the 90h instruction. The 92h instruction is called a 1,2,2 transfer, where the instruction is transferred on a single pin (SI), and the address and data are driven on two pins (SI and SO).

The instruction is initiated by driving the \overline{CS} pin low and shifting the instruction code 92h followed by a 24-bit address (A23-A0) of 000000h. After which, the Manufacturer ID for Dialog Semiconductor (1Fh) and the Device ID (16h) are shifted out on the falling edge of SCK with most significant bit (MSB) first as shown in Figure 7-44. A minimum of eight clock cycles are required to transfer the information.

If the 24-bit address is initially set to 000001h the Device ID is read first and then followed by the Manufacturer ID. The Manufacturer and Device ID can be read continuously, alternating from one to the other. The instruction is completed by driving \overline{CS} high.

Figure 7-44. Read Dual Manufacturer/ Device ID Dual I/O Instruction (SPI Mode)

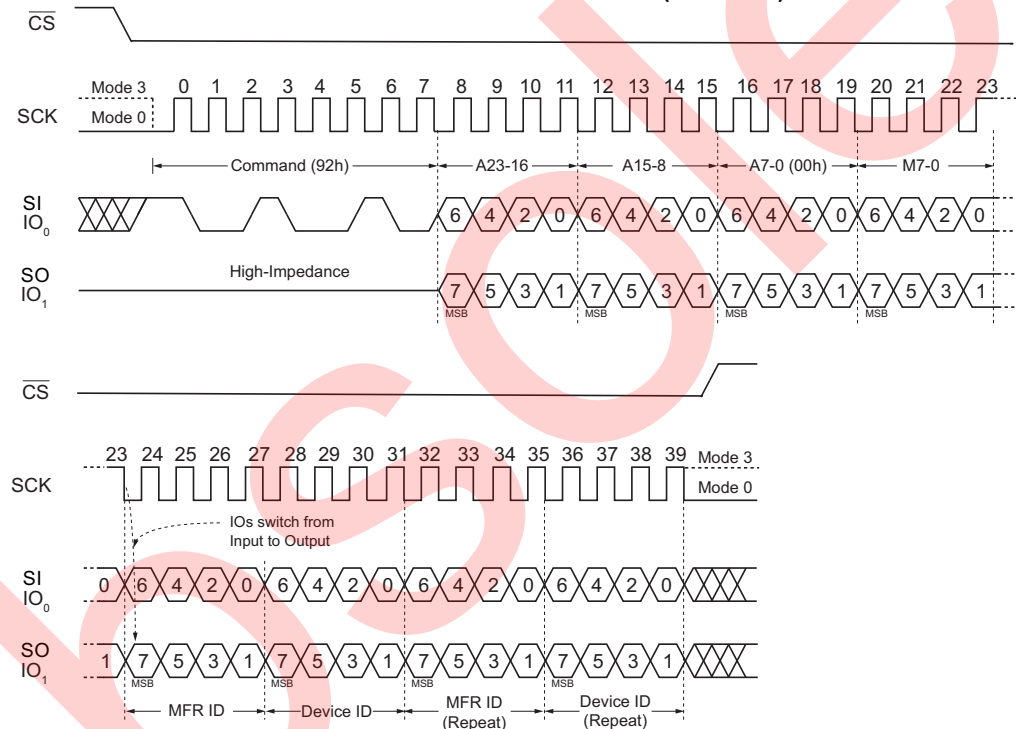

7.27 Read Manufacturer / Device ID Quad I/O (94h)

The Read Manufacturer/Device ID Quad I/O instruction provides both the JEDEC assigned manufacturer ID and the specific device ID. This command allows both address and manufacturer/device ID information to be driven on the SI (IO₀), SO (IO₁), WP (IO₂), and HOLD (IO₃) pins. During the address transfer, the IO₀, IO₁, IO₂, and IO₃ pins are inputs, allowing the 24-bit address to be transferred in only 6 clocks. Device hardware then switches these pins to outputs and drives the manufacturer/device ID information on these pins, transferring the information in one-fourth the number of clocks required by the 90h instruction. The 94h instruction is called a 1,4,4 transfer, where the instruction is transferred on a single pin (IO₀), and the address and data are driven on four pins (IO₀ - IO₃).

The instruction is initiated by driving the \overline{CS} pin low and shifting the instruction code 94h followed by a 24-bit address (A23-A0) of 000000h. After which, the Manufacturer ID for Dialog Semiconductor (1Fh) and the Device ID (16h) are shifted out on the falling edge of SCK with most significant bit (MSB) first as shown in Figure 7-45. If the 24-bit address

is initially set to 000001h the Device ID will be read first and then followed by the Manufacturer ID. The Manufacturer and Device ID can be read continuously, alternating from one to the other. The instruction is completed by driving $\overline{\text{CS}}$ high.

Figure 7-45. Read Quad Manufacturer/ Device ID Quad I/O Instruction (SPI Mode)

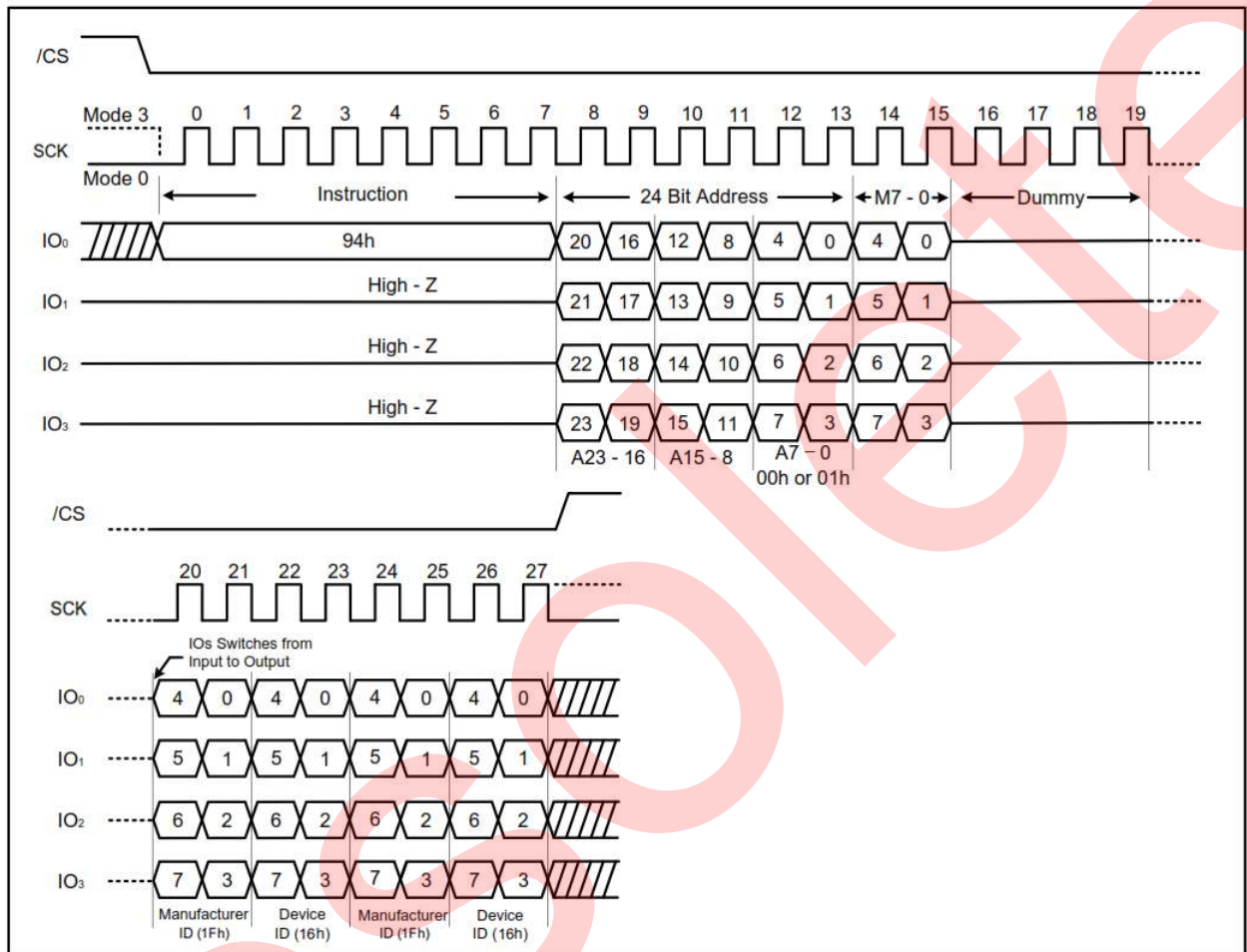

7.28 JEDEC ID (9Fh)

For compatibility reasons, the AT25QF641 provides several instructions to electronically determine the identity of the device. The Read JEDEC ID instruction is congruous with the JEDEC standard for SPI compatible serial Flash memories that was adopted in 2003.

The instruction is entered by driving the $\overline{\text{CS}}$ pin low with following the instruction code 9Fh. The JEDEC assigned Manufacturer ID byte for Dialog Semiconductor (1Fh) and two Device ID bytes, Memory Type (ID15-ID8) and Capacity (ID7-ID0) are then shifted out on the falling edge of SCK with most significant bit (MSB) first shown in [Figure 7-46](#) and [Figure 7-47](#). For memory type and capacity values refer to Manufacturer and Device Identification table. The JEDEC ID can be read continuously. The instruction is terminated by driving $\overline{\text{CS}}$ high.

Figure 7-46. Read JEDEC ID Instruction (SPI Mode)

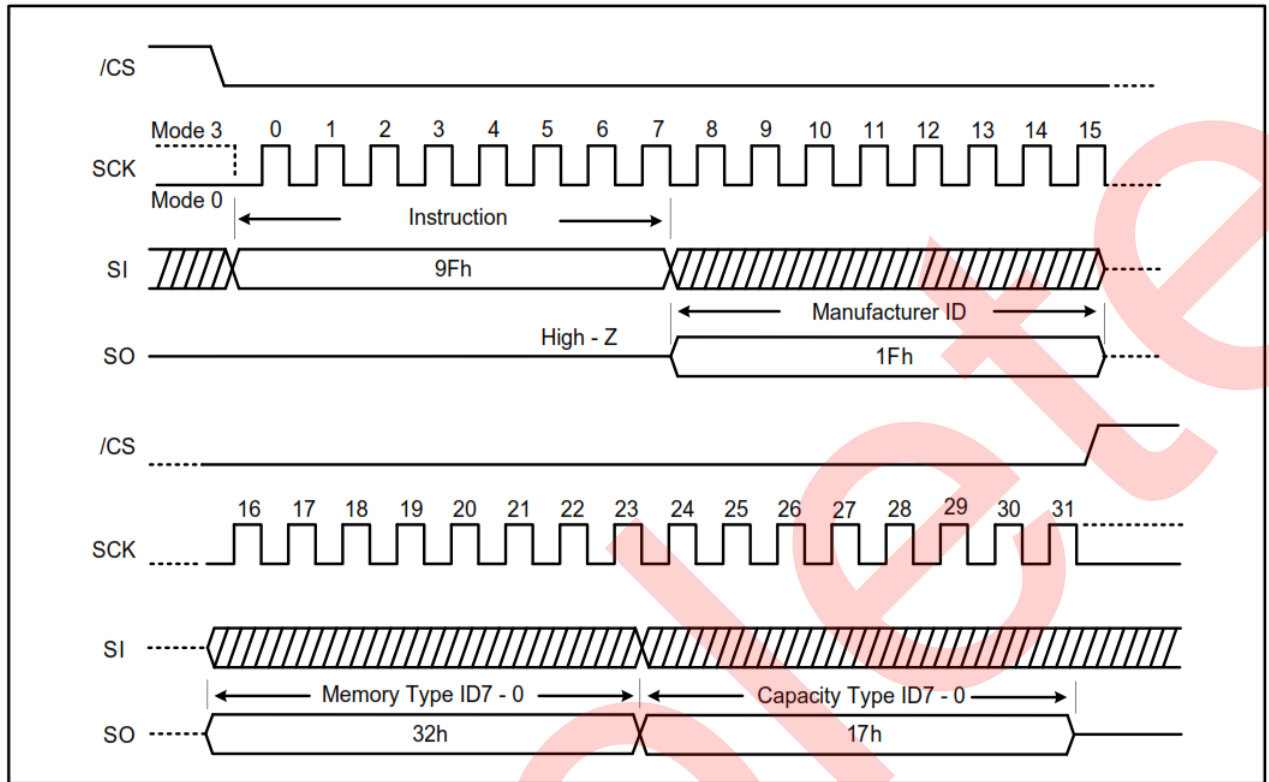
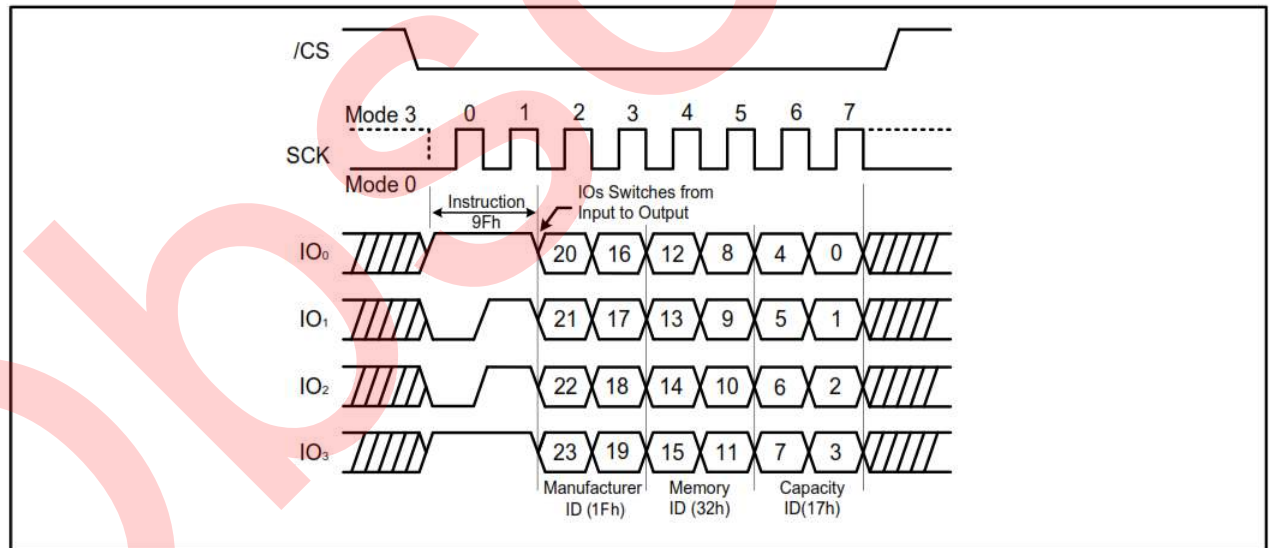

Figure 7-47. Read JEDEC ID Instruction (QPI Mode)



7.29 Enable QPI (38h)

The AT25QF641 support both Standard/Dual/Quad Serial Peripheral interface (SPI) and Quad Peripheral Interface (QPI). However, SPI mode and QPI mode cannot be used at the same time. The 'Enable QPI' instruction is the only way to switch the device from SPI mode to QPI mode.

In order to switch the device to QPI mode, the Quad Enable (QE) bit in Status Register 2 must be set to 1 first, and an Enable QPI instruction must be issued. If the Quad Enable (QE) bit is 0, the Enable QPI instruction is ignored and the device remains in SPI mode.

After power-up, the default state of the device is SPI mode. See the instruction Set [Table 7-2](#) for all the commands supported in SPI mode and the instruction Set [Table 7-5](#) for all the instructions supported in QPI mode.

When the device is switched from SPI mode to QPI mode, the existing Write Enable and Program/Erase Suspend status, and the Wrap Length setting will remain unchanged.

Figure 7-48. Enable QPI Instruction (SPI Mode only)

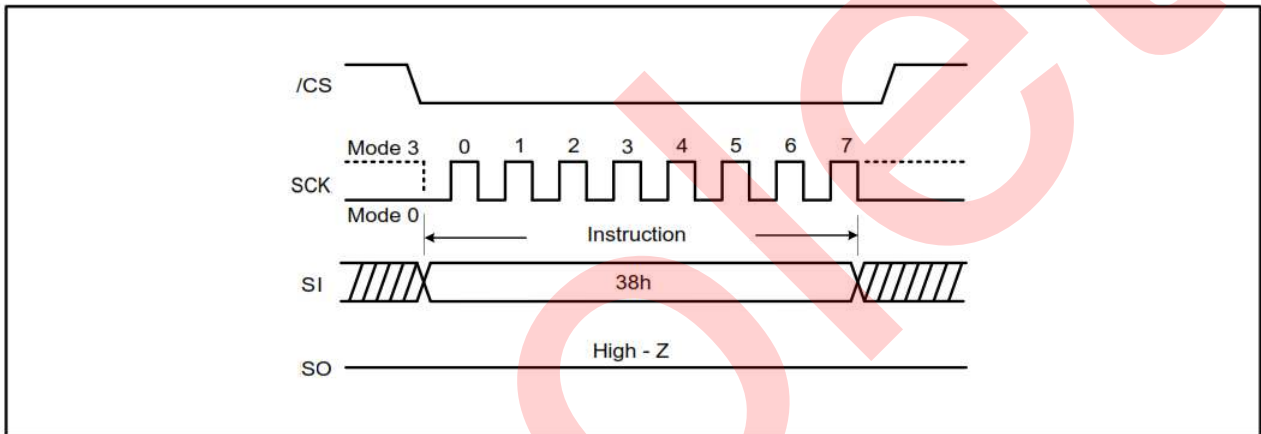

7.30 Disable QPI (FFh)

By issuing the Disable QPI (FFh) instruction, the device is reset to SPI mode. When the device is switched from QPI mode to SPI mode, the existing Write Enable Latch (WEL) and Program/Erase Suspend status, and the Wrap Length settings remains unchanged.

Figure 7-49. Disable QPI Instruction for QPI mode

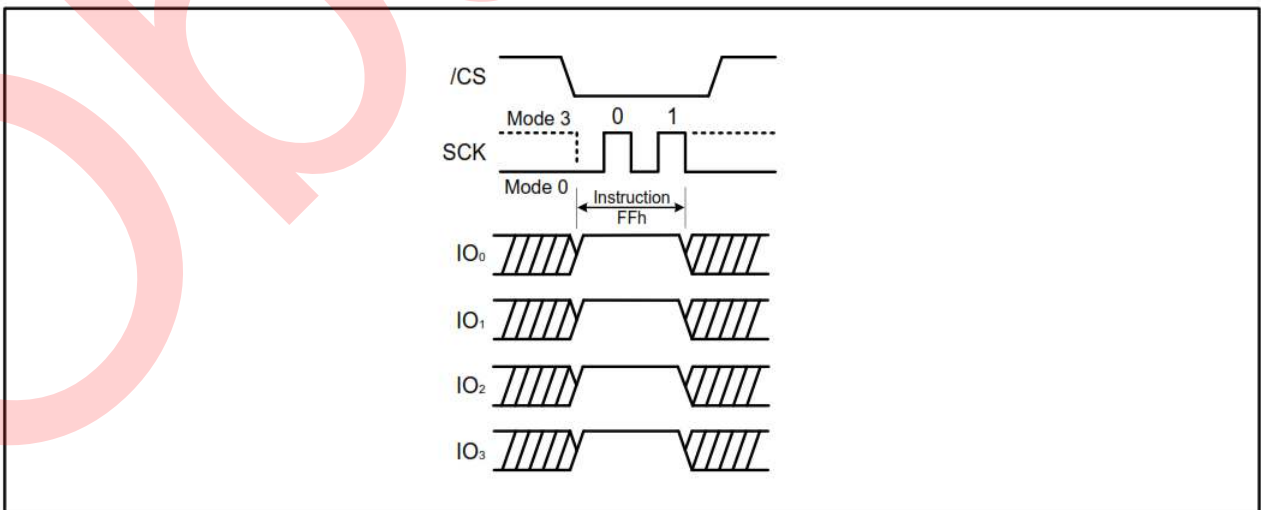

7.31 Word Read Quad I/O (E7h)

The Quad I/O dramatically reduces instruction overhead allowing faster random access for code execution (XIP) directly from the Quad SPI. The Quad Enable bit (QE) of Status Register-2 must be set to enable the Word Read Quad I/O instruction. The lowest Address bit (A0) must equal 0 and only two dummy clocks are required prior to the data output.

Continuous Read Mode

The Word Read Quad I/O instruction can further reduce instruction overhead through setting the Continuous Read Mode bits (M7-0) after the input address bits (A23-0), as shown in **Figure 7-50**. The upper nibble of the (M7-4) controls the length of the next Word Read Quad I/O instruction through the inclusion or exclusion of the first byte instruction code. The lower nibble bits of the (M[3:0]) are don't care ("X"). However, the IO pins should be high-impedance prior to the falling edge of the first data out clock.

If the Continuous Read Mode bits $M[7-4] = Ah$, then the next Fast Read Quad I/O instruction (after \overline{CS} is raised and then lowered) does not require the E7h instruction code, as shown in **Figure 7-51**. This reduces the instruction sequence by eight clocks and allows the Read address to be immediately entered after \overline{CS} is asserted low. If the Continuous Read Mode bits $M[7:4]$ do not equal Ah (1010), the next instruction (after \overline{CS} is raised and then lowered) requires the first byte instruction code, thus returning to normal operation.

Figure 7-50. Word Read Quad I/O Instruction (Initial instruction or previous set $M7-0 \neq Ah$, SPI Mode)

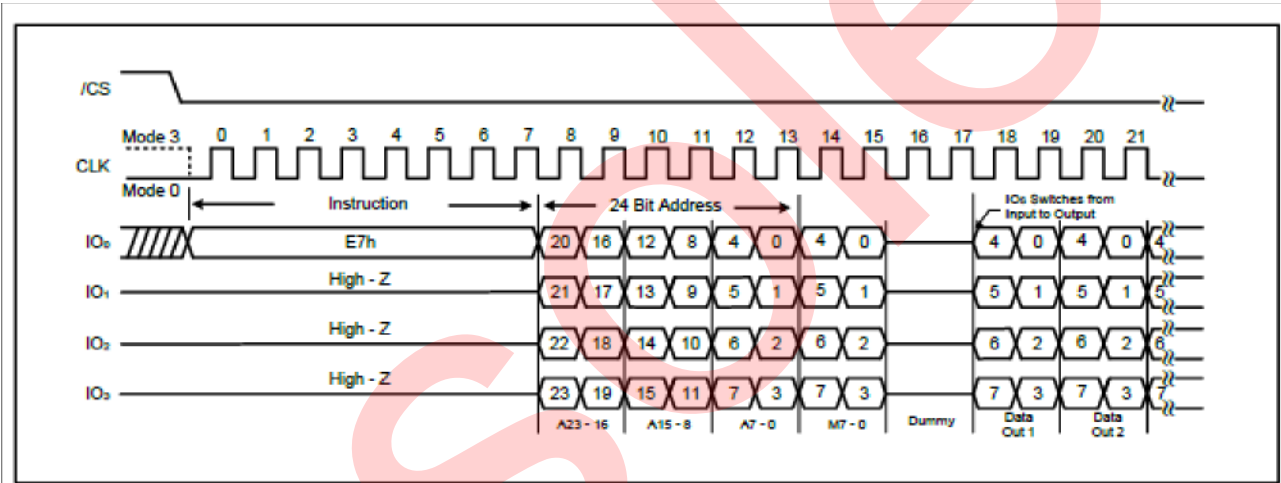
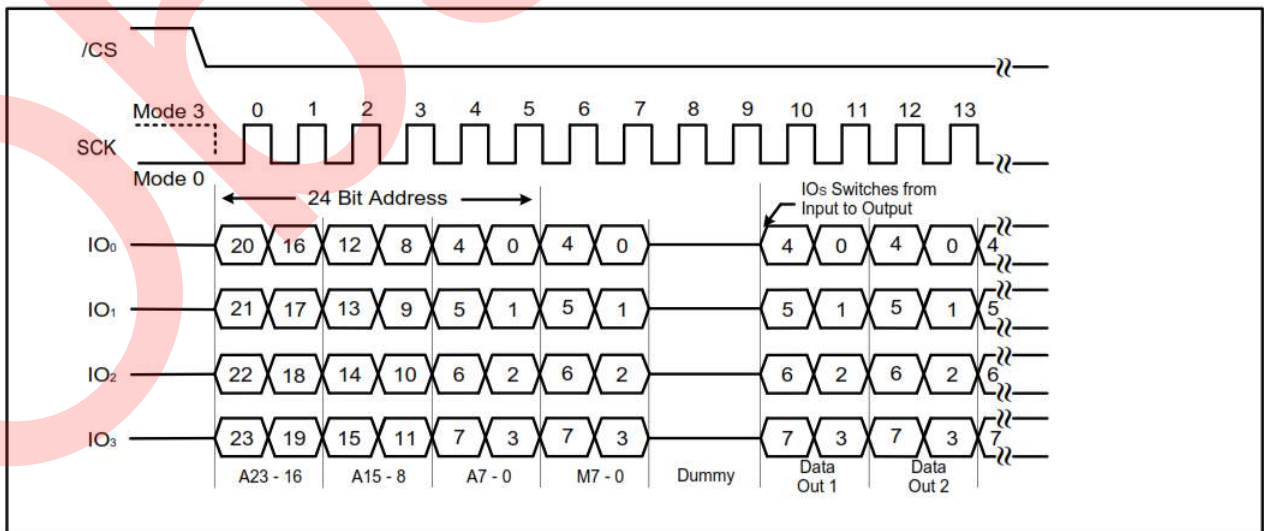

Figure 7-51. Word Read Quad I/O Instruction (Previous instruction set $M7-0 = Ah$, SPI Mode)



Wrap Around in SPI mode

The Word Read Quad I/O instruction can also be used to access a specific portion within a page by issuing a Set Burst with Wrap (77h) instruction prior to E7h. The Set Burst with Wrap (77h) instruction can either enable or disable the 'Wrap Around' feature for the following E7h commands. When 'Wrap Around' is enabled, the output data starts at the initial address specified in the instruction, once it reaches the ending boundary of the 8/16/32/64-byte section, the output wraps around to the beginning boundary automatically until \overline{CS} is pulled high to terminate the instruction.

The Burst with Wrap feature allows applications that use cache to quickly fetch a critical address and then fill the cache afterwards within a fixed length (8/16/32/64-byte) of data without issuing read instructions.

The Set Burst with Wrap instruction allows three 'Wrap Bits', W6-4 to be set. The W4 bit is used to enable or disable the "Wrap Around" operation while W6-5 is used to specify the length of the wrap around section within a page.

7.32 Set Burst with Wrap (77h)

The Set Burst with Wrap (77h) instruction is used in conjunction with Fast Read Quad I/O and Word Read Quad I/O instructions to access a fixed length section or of 8/16/32/64-byte section within a 256-byte page. Certain applications can benefit from this feature and improve the overall system code execution performance. Before the device can accept the Set Burst with Wrap instruction, a Quad enable of Status Register-2 must be executed (Status Register bit QE must equal 1).

The Set Burst with Wrap instruction is initiated by driving the \overline{CS} pin low and then shifting the instruction code "77h" followed by 24 dummy bits and eight 'Wrap Bits', W7-0. The instruction sequence is shown in Set Burst with Wrap Instruction Sequence. Wrap bit W7 and W3-0 are not used.

Table 7-6. Set Burst with Wrap W6:W4 Encoding

W6, W5	W4 = 0		W4 = 1 (Default)	
	Wrap Around	Wrap Length	Wrap Around	Wrap Length
00	Yes	8-byte	No	N/A
01	Yes	16-byte	No	N/A
10	Yes	32-byte	No	N/A
11	Yes	64-byte	No	N/A

Once W6-4 are set by a Set Burst with Wrap instruction, all the following Fast Read Quad I/O and Word Read Quad I/O instructions will use the W6-4 setting to access the 8/16/32/64-byte section within any page. To exit the 'Wrap Around' function and return to normal read operation, another Set Burst with Wrap instruction should be issued to set W4 = 1. The default value of W4 upon power on is 1. In the case of a system Reset while W4 = 0, it is recommended that the controller issues a Set Burst with Wrap instruction or Reset (99h) instruction to reset W4 = 1 prior to any normal Read instructions since AT25QF641 does not have a hardware reset pin.

Figure 7-52. Set Burst with Wrap Instruction Sequence

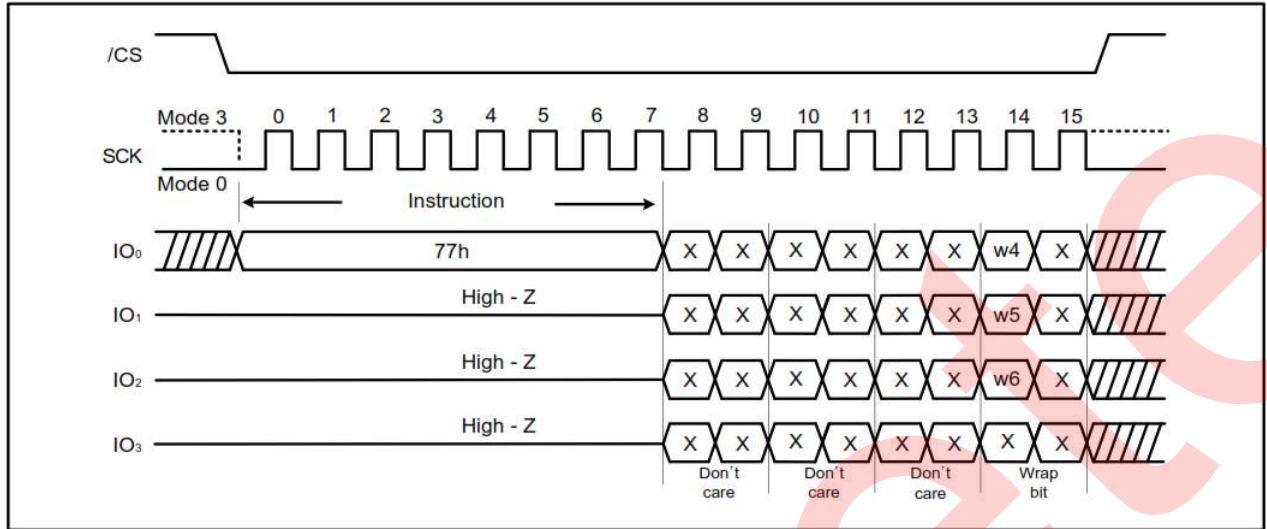

7.33 Burst Read with Wrap (0Ch)

The Burst Read with Wrap (0Ch) instruction provides an alternative way to perform the read operation with 'Wrap Around' in QPI mode. The instruction is similar to the Fast Read (0Bh) instruction in QPI mode, except the addressing of the read operation wraps around to the beginning boundary set by 'Wrap Length' once the ending boundary is reached.

The 'Wrap Length' and the number of dummy of clocks can be configured by the Set Read Parameters (C0h) instruction.

Figure 7-53. Burst Read with Wrap Instruction (QPI Mode, 80 MHz)

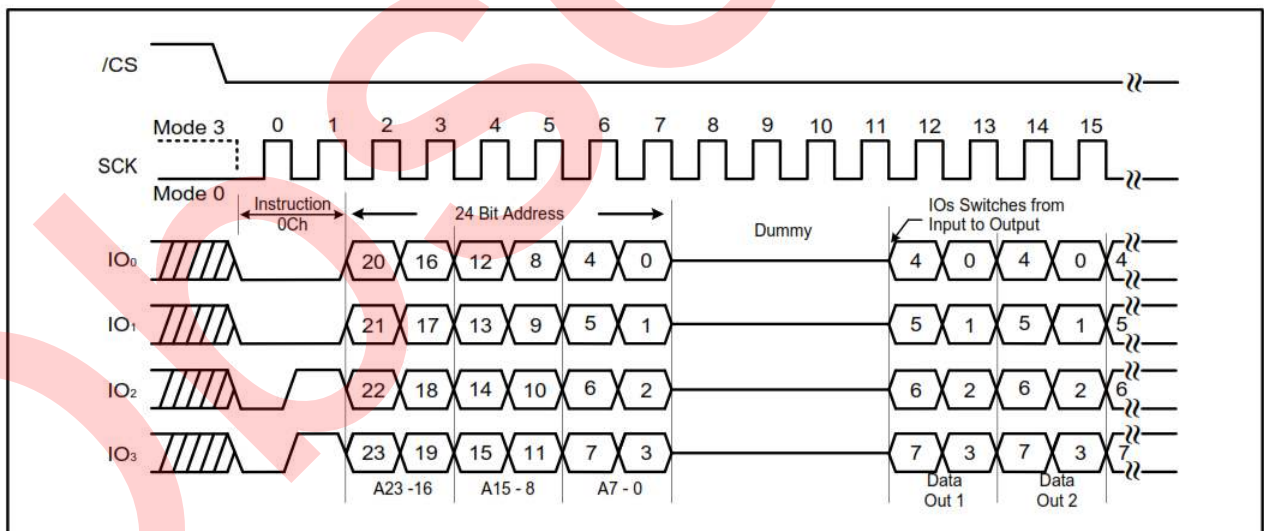
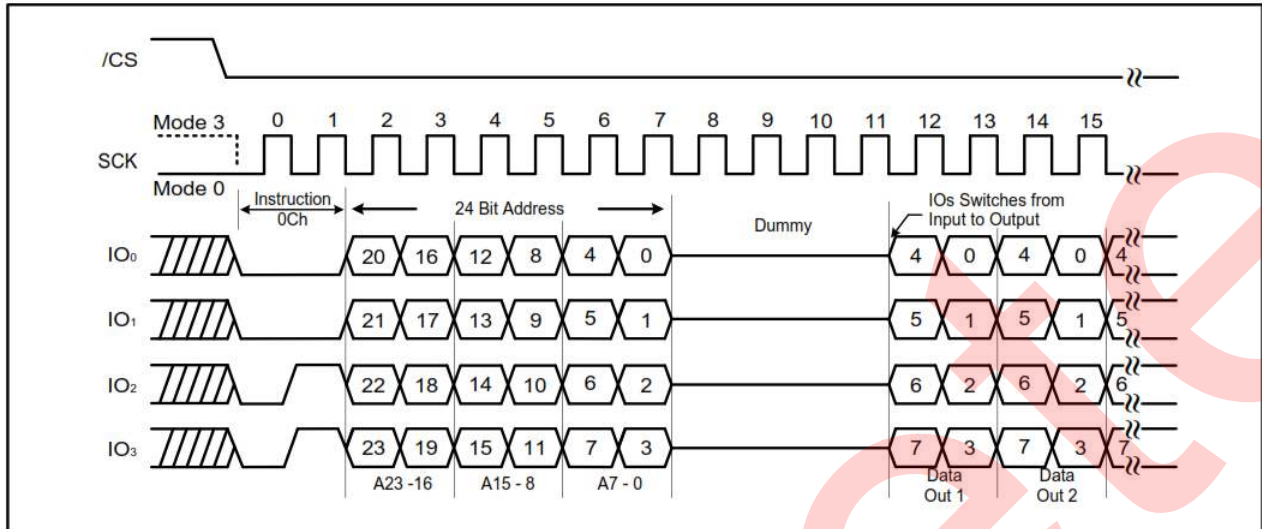

Figure 7-54. Burst Read with Wrap Instruction (QPI Mode, 104 MHz)



7.34 Set Read Parameters (C0h)

In QPI mode, to accommodate a wide range of applications with different needs for either maximum read frequency or minimum data access latency, the Set Read Parameters (C0h) instruction can be used to configure the number of dummy clocks for the Fast Read (0Bh), Fast Read Quad I/O (EBh), and Burst Read with Wrap (0Ch) instructions, and also configure the number of bytes of 'Wrap Length' for the Burst Read with Wrap (0Ch) instruction.

In Standard SPI mode, the Set Read Parameters (C0h) instruction is not accepted. The dummy clocks for various Fast Read instructions in Standard/Dual/Quad SPI mode are fixed. Please refer to the corresponding instruction. The encoding for the number of dummy clocks and wrap length are shown in the following tables. The default 'Wrap Length' after a power up or a Reset instruction is 8 bytes, the default number of dummy clocks is 4.

Table 7-7. Dummy Clock Encoding

P5, P4	Dummy Clocks	Maximum Read Frequency
00	4	80MHz
01	4	80MHz
10	6	104MHz

Table 7-8. Wrap Length Encoding

P1, P0	Wrap Length
00	8-bytes
01	16-bytes
10	32-bytes
11	64-bytes

Figure 7-55. Set Read Parameters Instruction (QPI Mode)

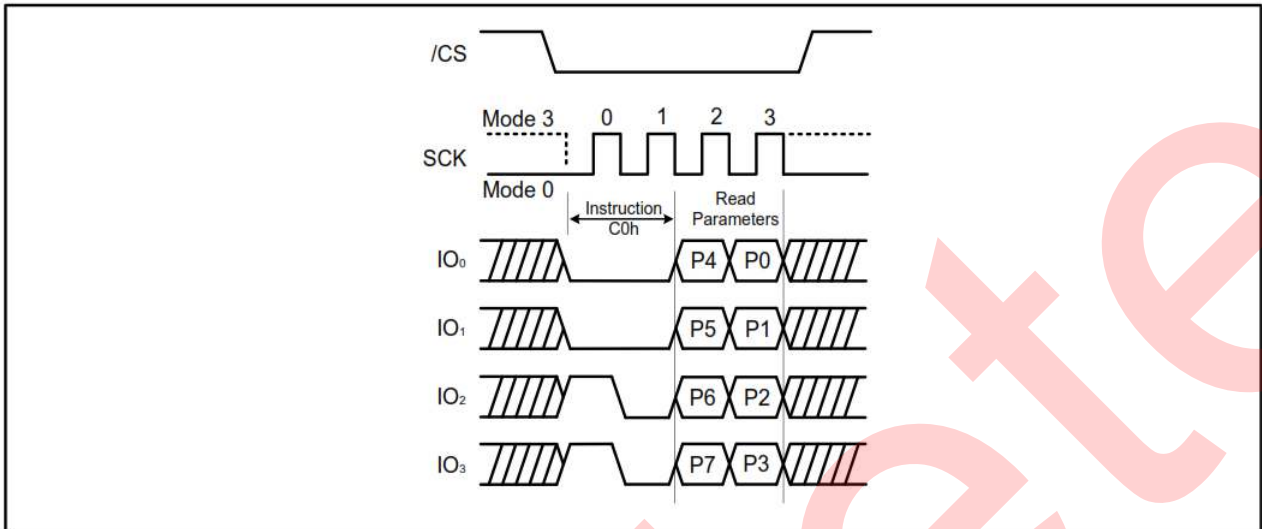

7.35 Enable Reset (66h) and Reset (99h)

Because of the small package and the limitation on the number of pins, the AT25QF641 provides a software reset instruction instead of a dedicated RESET pin.

Once the Reset instruction is accepted, any on-going internal operations are terminated and the device returns to its default power-on state and loses all the current volatile settings, such as Volatile Status Register bits, Write Enable Latch (WEL) status, Program/Erase Suspend status, Continuous Read Mode bit setting, Read parameter setting and Wrap bit setting.

The Enable Reset (66h) and Reset (99h) instructions can be issued in either SPI mode or QPI mode. To avoid accidental reset, both instructions must be issued in sequence. Any instruction other than Reset (99h) after the Enable (66h) instruction disables the Reset Enable state. A new sequence of Enable Reset (66h) and Reset (99h) is needed to reset the device. Once the Reset instruction is accepted by the device takes approximately $t_{RST} = 30 \mu s$ to reset. During this period, no instructions will be accepted.

Data corruption may happen if there is an on-going or suspended internal Erase or Program operation when Reset instruction sequence is accepted by device. It is recommended to check the BUSY bit and the SUS bit in Status Register before issuing the Reset instruction sequence.

Figure 7-56. Enable Reset and Reset Instruction (SPI Mode)

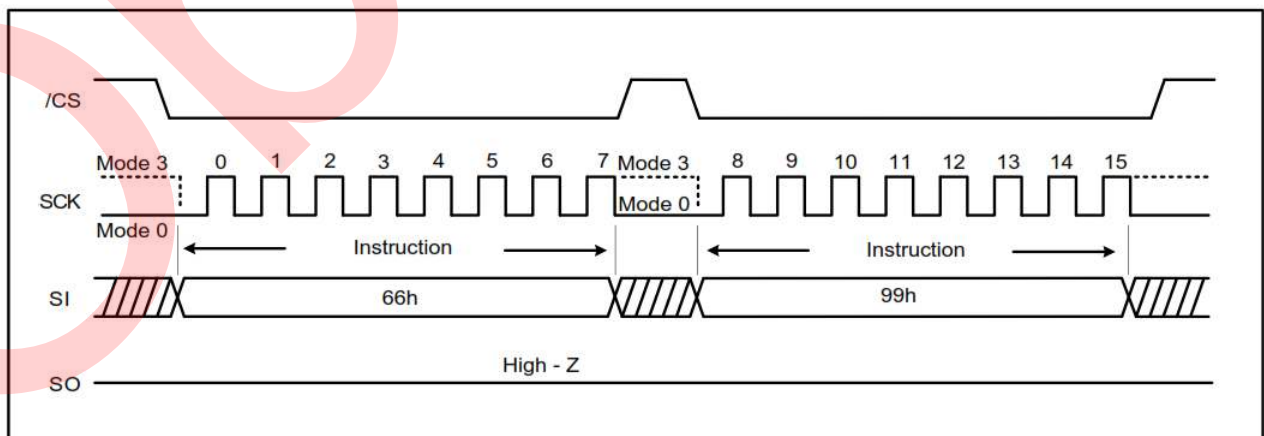
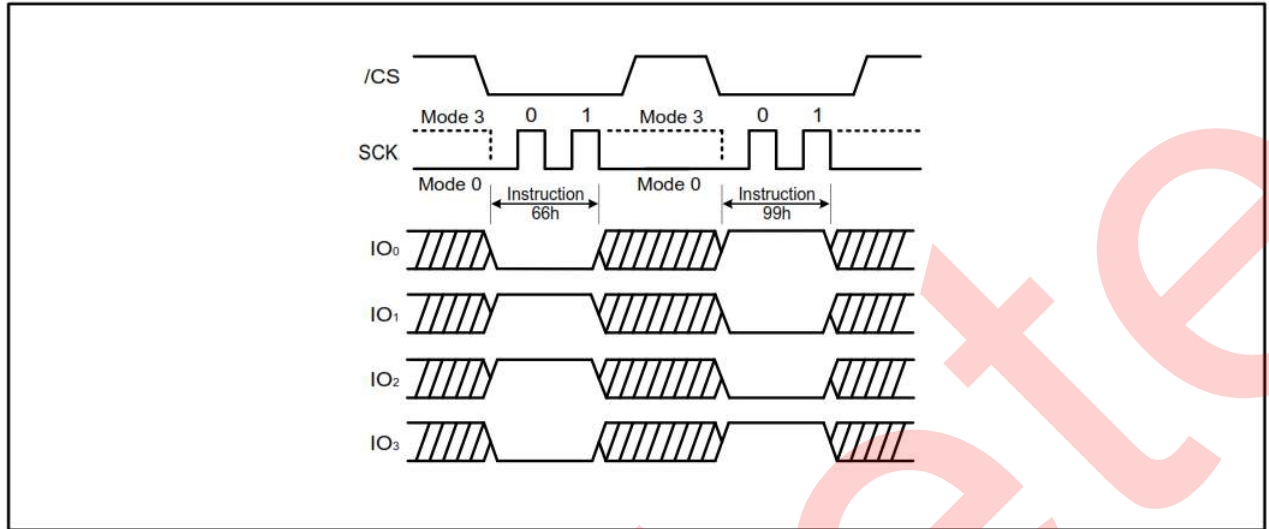

Figure 7-57. Enable Reset and Reset Instruction (QPI Mode)



7.36 Read Serial Flash Discovery Parameter (5Ah)

The Read Serial Flash Discovery Parameter (SFDP) instruction allows reading the Serial Flash Discovery Parameter area (SFDP). This SFDP area is composed of 2048 read-only bytes containing operating characteristics and vendor specific information.

The SFDP area is factory programmed. If the SFDP area is blank, the device is shipped with all the SFDP bytes at FFh. If only a portion of the SFDP area is written to, the portion not used is shipped with bytes in erased state (FFh). The instruction is executed by driving first driving Chip Select ($\overline{\text{CS}}$) low. Next, the 8-bit instruction code 5Ah and the 24-bit address are shifted in, followed by 8 dummy clock cycles. The bytes of SFDP content are shifted out on the Serial Data Output (SO) starting from the specified address. Each bit is shifted out during the falling edge of Serial Clock (SCK). The Read SFDP instruction is terminated by driving Chip Select ($\overline{\text{CS}}$) High at any time during data output.

Figure 7-58. Read SFDP Register Instruction

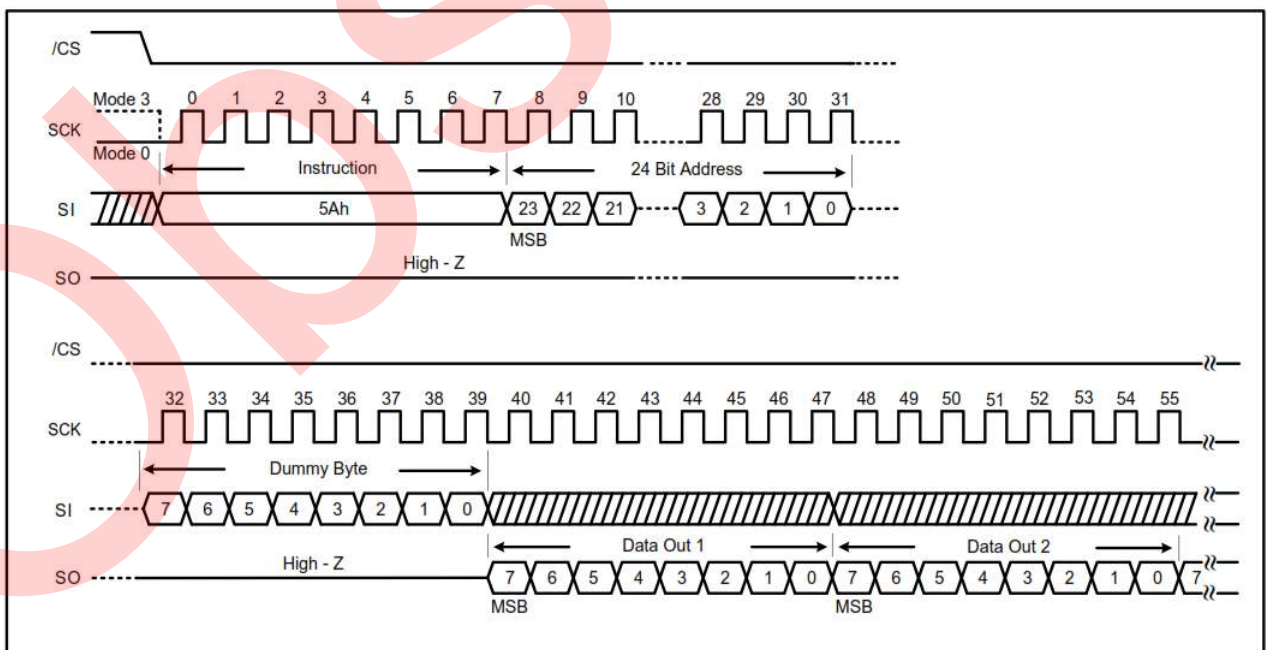

Table 7-9. SFDP Signature and Headers

Description	Comment	Address (h) Byte	Address (Bit)	Data (b) (Bit)	Data (h) (Byte)
SFDP Signature		00h	07:00	0101 0011	53h
		01h	15:08	0100 0110	46h
		02h	23:16	0100 0100	44h
		03h	31:24	0101 0110	50h
SFDP Minor Revision	Start from 00h	04h	07:00	0000 0110	06h
SFDP Major Revision	Start from 01h	05h	15:08	0000 0001	01h
Number of Parameters Headers	Start from 00h	06h	23:16	0000 0001	01h
Reserved	FFh	07h	31:24	1111 1111	FFh
JEDEC Parameter ID (LSB)	JEDEC Parameter ID (LSB) = 00h	08h	07:00	0000 0000	00h
Parameter Table Minor Revision	Start from 00h	09h	15:08	0000 0110	06h
Parameter Table Major Revision	Start from 01h	0Ah	23:16	0000 0001	01h
Parameter Table Length (double words)	How many DWORDs in the parameter table	0Bh	31:24	0001 0000	10h
Parameter Table Pointer	Address of Dialog Semiconductor Parameter Table	0Ch	07:00	0011 0000	30h
		0Dh	15:08	0000 0000	00h
		0Eh	23:16	0000 0000	00h
JEDEC Parameter ID (MSB)	JEDEC Parameter ID (MSB):FFh	0Fh	31:24	1111 1111	FFh
JEDEC Parameter ID (LSB)	Dialog Semiconductor Manufacturer ID	10h	07:00	0001 1111	1Fh
Parameter Table Minor Revision	Start from 00h	11h	15:08	0000 0000	00h
Parameter Table Major Revision	Start from 01h	12h	23:16	0000 0001	01h
Parameter Table Length (double words)	How many DWORDs in the parameter table	13h	31:24	0000 0010	02h
Parameter Table Pointer (PTP)	Address of Dialog Semiconductor Parameter Table	14h	07:00	1000 0000	80h
		15h	15:08	0000 0000	00h
		16h	23:16	0000 0000	00h
Reserved	FFh	17h	31:24	0000 0001	01h

Table 7-10. SFDP Parameters Table 1

Description	Comment	Address (h) Byte	Address (Bit)	Data (b) (Bit)	Data (h) (Byte)
Erase Granularity	01: 4KB available 11: 4KB not available	30h	01:00	01	E5h
Write Granularity	0: 1Byte 1: 64 bytes or larger		02	1	
Volatile Status Register Block Protect Bits	0: Nonvolatile status bit 1: Volatile status bit		03	0	
Volatile Status Register Write Enable Opcode	0: 50h Opcode to enable, if bit-3 = 1		04	0	
Reserved			07:05	111	
4 KB Erase Opccde	Opcode or FFh	31h	15:08	0010 0000	20h
Fast Dual Read Output (1 -1 -2)	0 = Not supported 1 = Supported	32h	16	1	F1h
Number of Address Bytes	00: 3 Byte only 01: 3 or 4 Byte 10: 4 Byte only 11: Reserved		18:17	00	
Double Transfer Rate (DTR) Clocking	0 = Not supported 1 = Supported		19	0	
Fast Dual I/O Read (1-2- 2)	0 = Not supported 1 = Supported		20	1	
Fast Quad I/O Read (1-4-4)	0 = Not supported 1 = Supported		21	1	
Fast Quad Output Read (1-1-4)	0 = Not supported 1 = Supported		22	1	
Reserved	FFh		23	1	
Reserved	FFh		33h	31:24	
Flash Memory Density		34h	07:00	1111 1111	FFh
		35h	15:08	1111 1111	FFh
		36h	23:16	1111 1111	FFh
		37h	31:24	0000 0011	03h
Fast Quad I/O (1-4-4) Number of dummy clocks	Number of dummy clocks	38h	04:00	00100	44h
Fast Quad I/O (1-4-4) Number of mode bits	Number of mode bits		07:05	010	
Fast Quad I/O (1-4-4) Read Opcode	Opcode or FFh	39h	15:08	1110 1011	EBh

Table 7-10. SFDP Parameters Table 1 (Continued)

Description	Comment	Address (h) Byte	Address (Bit)	Data (b) (Bit)	Data (h) (Byte)
Fast Quad Output (1-1-4) Number of dummy clocks	Number of dummy clocks	3Ah	20:16	01000	08h
Fast Quad Output (1-1-4) Number of mode bits	Number of mode bits		23:21	000	
Fast Quad Output (1-1-4) Read Opcode	Opcode or FFh	3Bh	31:24	0110 1011	6Bh
Fast Dual Output (1-1-2) Number of dummy clocks	Number of dummy clocks	3Ch	04:00	01000	08h
Fast Dual Output (1-1-2) Number of mode bits	Number of mode bits		07:05	000	
Fast Dual Output (1-1-2) Read Opcode	Opcode or FFh	3Dh	15:08	0011 1011	3Bh
Fast Dual I/O (1-2-2) Number of dummy clocks	Number of dummy clocks	3Eh	20:16	00000	80h
Fast Dual I/O (1-2-2) Number of mode bits	Number of mode bits		23:21	100	
Fast Dual I/O (1-2-2) Read Opcode	Opcode or FFh	3Fh	31:24	1011 1011	BBh
Fast Dual DPI (2-2-2)	0 = Not supported 1 = Supported	40h	0	0	FEh
Reserved	FFh		03:01	111	
Fast Quad QPI (4-4-4)	0 = Not supported 1 = Supported		04	1	
Reserved	FFh		07:05	111	
Reserved	FFh	41h	15:08	1111 1111	FFh
Reserved	FFh	42h	23:16	1111 1111	FFh
Reserved	FFh	43h	31:24	1111 1111	FFh
Reserved	FFh	44h	07:00	1111 1111	FFh
Reserved	FFh	45h	15:08	1111 1111	FFh
Fast Dual DPI (2-2-2) Number of dummy clocks	Number of dummy clocks	46h	20:16	0 0000	00h
Fast Dual DPI (2-2-2) Number of mode bits	Number of mode bits		23:21	000	
Fast Dual DPI(2-2-2) Read Opcode	Opcode or FFh	47h	31:24	1111 1111	FFh
Reserved	FFh	48h	07:00	1111 1111	FFh
Reserved	FFh	49h	15:08	1111 1111	FFh

Table 7-10. SFDP Parameters Table 1 (Continued)

Description	Comment	Address (h) Byte	Address (Bit)	Data (b) (Bit)	Data (h) (Byte)
Fast Quad QPI (4-4-4) Number of dummy clocks	Number of dummy clocks	4Ah	20:16	00010	42h
Fast Quadl QPI (4-4-4) Number of mode bits	Number of mode bits		23:21	010	
Fast Quad QPI(4-4-4) Read Opcode	Opcode or FFh	4Bh	31:24	1110 1011	EBh
Erase type-1 Size	4KB = 2 ⁰ Ch, 32 KB = 2 ⁰ Fh, 64KB = 2 ¹ 0h; (2 ^N nbyte)	4Ch	07:00	0000 1100	0Ch
Erase type-1 Opcode	Opcode or FFh	4Dh	15:08	0010 0000	20h
Erase type-2 Size	4KB = 2 ⁰ Ch, 32 KB = 2 ⁰ Fh, 64KB = 2 ¹ 0h; (2 ^N nbyte)	4Eh	23:16	0000 1111	0Fh
Erase type-2 Opcode	Opcode or FFh	4Fh	31:24	0101 0010	52h
Erase Type-3 Size	4KB = 2 ⁰ Ch, 32 KB = 2 ⁰ Fh, 64KB = 2 ¹ 0h; (2 ^N nbyte)	50h	07:00	0001 0000	10h
Erase Type-3 Opcode	Opcode or FFh	51h	15:08	1101 1000	D8h
Erase Type-4 Size	4KB = 2 ⁰ Ch, 32 KB = 2 ⁰ Fh, 64KB = 2 ¹ 0h; (2 ^N nbyte)	52h	23:16	0000 0000	00h
Erase Type-4 Opcode	Opcode or FFh	53h	31:24	1111 1111	FFh
Erase Maximum/Typical Ratio	Maximum = 2 * (COUNT + 1) * Typical	54h 55h 56h 57h	03:00	0011	33h 62h C9h 00h
Erase type-1 Typical time	Count or 00h		08:04	0 0011	
Erase type-1 Typical units	00b: 1ms 01b: 16ms 10b: 128ms 11b: 1s		10:09	01	
Erase type-2 Typical time	Count or 00h		15:11	0110 0	
Erase type-2 Typical units	00b: 1ms 01b: 16ms 10b: 128ms 11b: 1s		17:16	01	
Erase type-3 Typical time	Count or 00h		22:18	100 10	
Erase type-3 Typical units	00b: 1ms 01b: 16ms 10b: 128ms 11b: 1s		24:23	01	
Erase type-4 Typical time	Count or 00h		29:25	00 000	
Erase type-4 Typical units	00b: 1ms 01b: 16ms 10b: 128ms 11b: 1s		31:30	00	

Table 7-10. SFDP Parameters Table 1 (Continued)

Description	Comment	Address (h) Byte	Address (Bit)	Data (b) (Bit)	Data (h) (Byte)
Program Maximum/Typical Ratio	Maximum = 2 * (COUNT + 1) * Typical	58h	03:00	0100	84h
Page Size	2^N bytes		07:04	1000	
Program Page Typical time	Count or 00h	59h 5Ah 5Bh	12:08	0 1001	29h 01h C7h
Program Page Typical units	0: 8 μs, 1: 64 μs		13	1	
Program Byte Typical time, 1st byte	Count or 00h		17:14	01 00	
Program Byte Typical units, 1st byte	0: 1 μs, 1: 8 μs		18	0	
Program Additional Byte Typical time	Count or 00h		22:19	000 0	
Program Additional Byte Typical units	0: 1 μs, 1: 8 μs		23	0	
Erase Chip Typical time	Count or 00h		28:24	0 1110	
Erase Chip Typical units	00b: 16 ms 01b: 256 ms 10b: 4 sec 11b: 64 sec		30:29	10	
Reserved	1h		31	1	
Prohibited Op during Program Suspend	See Datasheet		5Ch	03:00	
Prohibited Op during Erase Suspend	See Datasheet	07:04		1110	

Table 7-10. SFDP Parameters Table 1 (Continued)

Description	Comment	Address (h) Byte	Address (Bit)	Data (b) (Bit)	Data (h) (Byte)
Reserved	1h	5Dh 5Eh 5Fh	08	1	A1h 07h 3Dh
Program Resume to Suspend time	Count of 64 μ s		12:09	0 000	
Program Suspend Maximum time	Count or 00h		17:13	11 101	
Program Suspend Maximum units	00b: 128 ns 01b: 1 μ s 10b: 8 μ s 11b: 64 μ s		19:18	01	
Erase Resume to Suspend time	Count of 64 μ s		23:20	0000	
Erase Suspend Maximum time	Count or 00h		28:24	1 1101	
Erase Suspend Maximum units	00b: 128 ns 01b: 1 μ s 10b: 8 μ s 11b: 64 μ s		30:29	01	
Suspend / Resume supported	0: Program and Erase suspend supported 1: Not supported		31	0	
Program Resume Opcode	Opcode or FFh	60h	7:0	0111 1010	7Ah
Program Suspend Opcode	Opcode or FFh	61h	15:8	0111 0101	75h
Resume Opcode	Opcode or FFh	62h	23:16	0111 1010	7Ah
Suspend Opcode	Opcode or FFh	63h	31:24	0111 0101	75h
Reserved	11b	64h	01:00	11	F7h
Status Register Busy Polling	xxxx1b: Opcode = 05h, bit 0 = 1 Busy, xxxx1xb: Opcode = 70h, bit 7 = 0 Busy, Others: reserved		07:02	1111 01	

Table 7-10. SFDP Parameters Table 1 (Continued)

Description	Comment	Address (h) Byte	Address (Bit)	Data (b) (Bit)	Data (h) (Byte)		
Exit Deep Powerdown time	Count or 00h	65h 66h 67h	12:08	0 0010	A2h D5h 5Ch		
Exit Deep Powerdown units	00b: 128 ns 01b: 1 μs 10b: 8 μs 11b: 64 μs		14:13	01			
Exit Deep Powerdown Opcode	Opcode or FFh		22:15	101 0101 1			
Enter Deep Powerdown Opcode	Opcode or FFh		30:23	101 1100 1			
Deep Powerdown Supported	0: Deep Powerdown supported, 1: not supported		31	0			
Disable 4-4-4 Read Mode		68h 69h 6Ah	03:00	1001	19h F6h 1Ch		
Enable 4-4-4 Read Mode			08:04	0 0001			
Fast Quad I/O Continuous (0-4-4) supported	0: not supported, 1: Quad I/O 0-4-4 supported		09	1			
Fast Quad I/O Continuous (0-4-4) Exit			15:10	1111 01			
Fast Quad I/O Continuous (0-4-4) Enter			19:16	1100			
Quad Enable Requirements (QER)			22:20	001			
HOLD or RESET Disable	0: not supported 1: use Configuration Register bit-4		23	0			
Reserved	FFh		6Bh	31:24		1111 1111	FFh
Status Register Opcode			6Ch	06:00		110 1000	E8h
Reserved	1h			07		1	
Soft Reset Opcodes		6Dh	13:08	01 0000	10h C0h		
4-Byte Address Exit		6Eh	23:14	1100 0000 00			
4-Byte Address Enter		6Fh	31:24	1000 0000	80h		

Table 7-11. SFDP Parameters Table 2

Description	Comment	Address (h) Byte	Address (Bit)	Data (b) (Bit)	Data (h) (Byte)
VCC Minimum Voltage	1650h: 1.65V 1700h: 1.70V 2300h: 2.30V 2500h: 2.50V 2700h: 2.70V	80h 81h	15:0	0000 0000 0001 0111	00h 27h
VCC Maximum Voltage	1950h: 1.95V 3600h: 3.60V 4000h: 4.00V 4400h: 4.40V	82h 83h	31:16	0000 0000 0011 0110	00h 36h
Array Protection Method	10b: use non-volatile status register	84h 85h	01:00	10	DAh 06h
Power up Protection default	0: power up unprotected, 1: power up protected		02	0	
Protection Disable Opcodes	011b: use status register		05:03	01 1	
Protection Enable Opcodes	011b: use status register		08:06	0 11	
Protection Read Opcodes	011b: use status register		11:09	011	
Protection Register Erase Opcode	00b: Not supported, 01b: Opcodes 3Dh, 2Ah, 7Fh, CFh,		13:12	00	
Protection Register Program Opcode	00b: not supported, 01b: Opcodes 3Dh, 2Ah, 7Fh, FCh		15:14	00	
Reserved	FFh	86h	23:16	1111 1111	FFh
Reserved	FFh	87h	31:24	1111 1111	FFh
Reserved	FFh	88h - FFh			Reserved

7.37 Enter Secured OTP (B1h)

The Enter Secured OTP instruction is for entering the additional 4 Kbit secured OTP mode. The additional 4 Kbit secured OTP is independent from main array, which can be used to store unique serial number for system identifier. After entering the Secured OTP mode, and then follow standard read or program, procedure to read out the data or update data. The Secured OTP data cannot be updated again once it is lock-down.

Please note that Write Status Register-1, Write Status Register-2 and Write Security Register instructions are not acceptable during the access of secure OTP region. Once security OTP is lock down, only commands related with read are valid. The Enter Secured OTP instruction sequence is shown in [Figure 7-59](#).

Figure 7-59. Enter Secured OTP Instruction for SPI Mode (left) and QPI Mode (right)

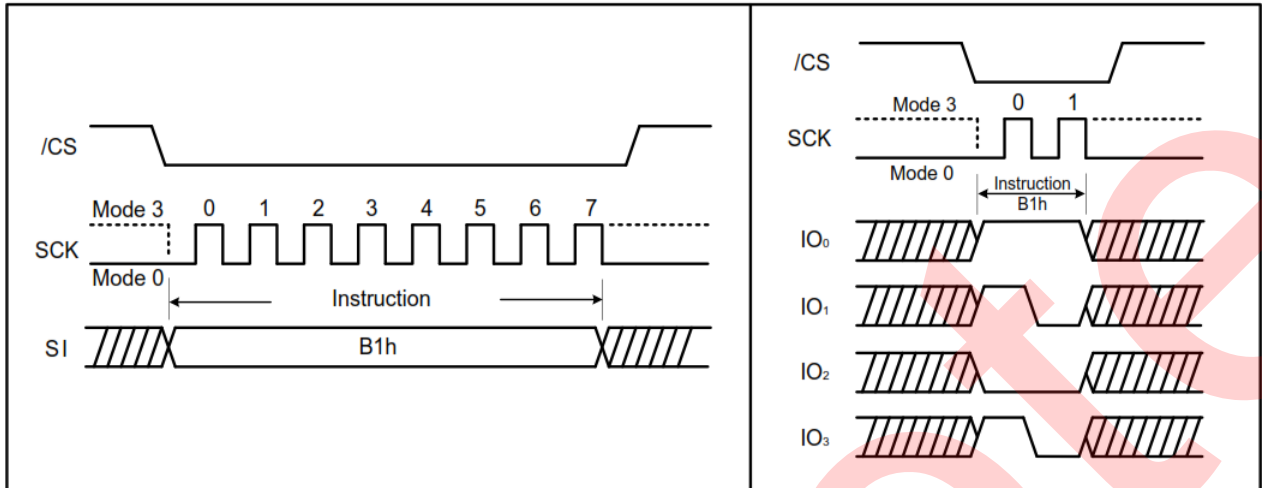

7.38 Exit Secured OTP (C1h)

The Exit Secured OTP instruction is for exiting the additional 4 Kbit secured OTP mode. Please refer to [Figure 7-60](#).

Figure 7-60. Exit Secured OTP Instruction for SPI Mode (left) and QPI Mode (right)

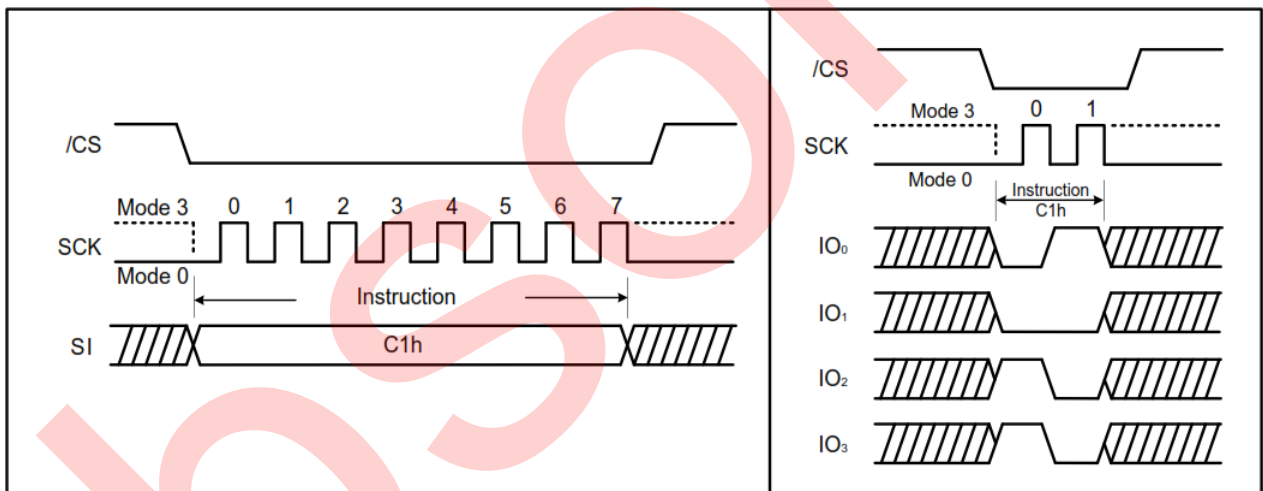

7.39 Read Security Register (2Bh)

The Read Security Register can be read the value of Security Register bits at any time (even in program/erase/write status register-1 and write status register-2 condition) and continuously.

Secured OTP Indicator bit. The Secured OTP indicator bit shows the chip is locked by factory before ex-factory or not. When it is “0”, it indicates non-factory lock, “1” indicates factory-lock.

Lock-down Secured OTP (LDSO) bit. By writing Write Security Register instruction, the LDSO bit can be set to ‘1’ for customer lock-down purpose. However, once the bit it set to ‘1’ (Lock-down), the LDSO bit and the 4 Kbit Secured OTP area cannot be updated any more. While it is in 4 Kbit Secured OTP mode, array write access is not allowed.

Table 7-12. Security Register Definition

Bit7	Bit6	Bit5	Bit4	Bit3	Bit2	Bit1	Bit0
x	x	x	x	x	x	LDSO (indicate if lock-down)	Secured OTP indicator bit
Reserved	Reserved	Reserved	Reserved	Reserved	Reserved	0 = not lock-down 1 = lock down (cannot program/erase OTP)	0 = non factory lock 1 = factory lock
Volatile bit	Volatile bit	Volatile bit	Volatile bit	Volatile bit	Volatile bit	Non-Volatile bit	Non-Volatile bit

Figure 7-61. Read Security Register Instruction (SPI Mode)

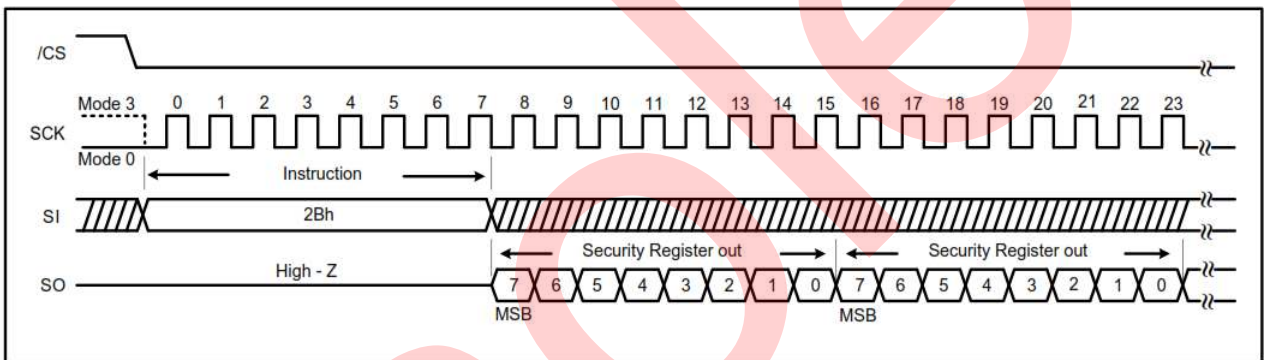
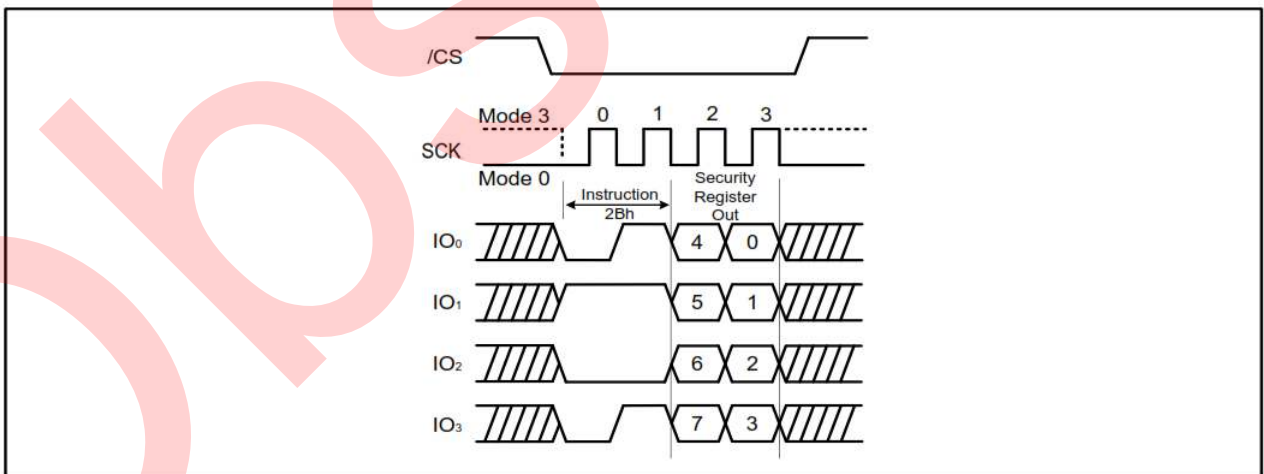

Figure 7-62. Read Security Register Instruction (QPI Mode)



7.40 Write Security Register (2Fh)

The Write Security Register instruction is for changing the values of Security Register bits. Unlike Write Status Register, the Write Enable instruction is not required before writing Write Security Register instruction. The Write Security Register instruction can change the value of bit 1 (LDSO bit) for customer to lock-down the 4 Kbit Secured OTP area. Once the LDSO bit is set to "1", the Secured OTP area cannot be updated any more.

The \overline{CS} must go high exactly at the boundary; otherwise, the instruction is rejected and not executed.

Figure 7-63. Write Security Register instruction for SPI Mode (left) and QPI Mode (right)

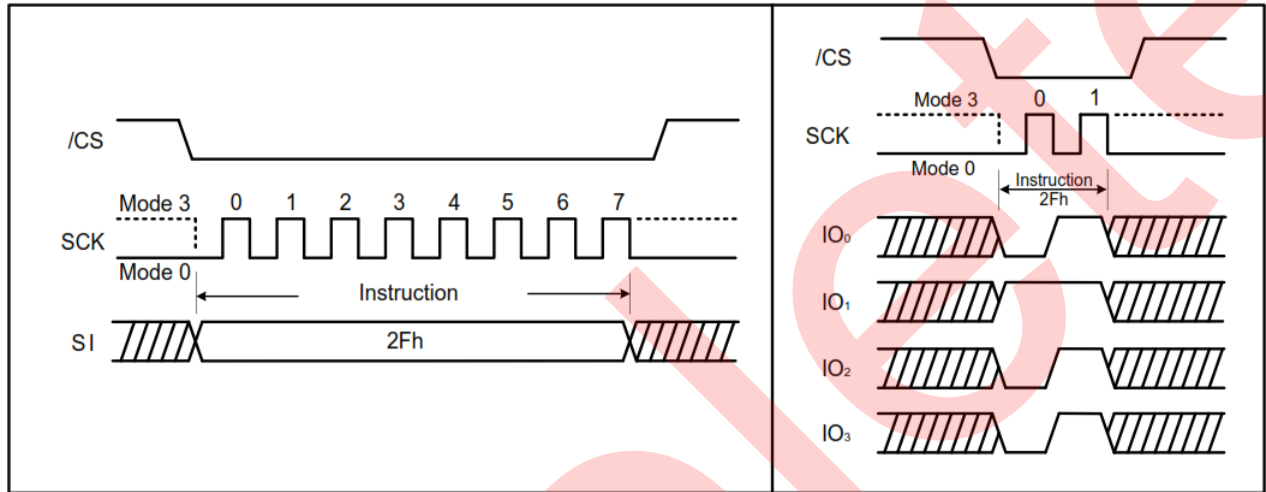

7.41 4 Kbit Secured OTP

It's for unique identifier to provide 4 Kbit one-time-program area for setting device unique serial number which can be set by factory or system customer. Please refer to [Table 7-13, Secured OTP Address Space](#).

- Security register bit 0 indicates whether the chip is locked by the factory or not.
- To program the 4 Kbit secured OTP by entering 4 Kbit secured OTP mode (with ENSO command) and going through normal program procedure, and then exiting 4 Kbit secured OTP mode by writing the EXSO command.
- Customer can lock-down bit 1 as '1'. Please refer to [Table 7-13, Secured OTP Address Space](#).

Note. Once lock-down whatever by factory or customer, it cannot be changed any more. While in 4 Kbit secured OTP mode, write access to the array is not allowed.

Table 7-13. Secured OTP Address Space

Address Range	Size	Standard	Customer Lock
000000 ~ 00000F	128-bit	ESN (Electrical Serial Number)	Determined by customer
000010 ~ 0001FF	3968-bit	N/A	

8. Electrical Characteristics

8.1 Absolute Maximum Ratings⁽¹⁾

Parameter	Symbol	Conditions	Range	Units
Supply Voltage	VCC		-0.6 to VCC+0.4	V
Voltage Applied to Any Pin	VIO	Relative to Ground	-0.6 to VCC +0.4	V
Transient Voltage on any Pin	VIOT	<20nS Transient Relative to Ground	-1.0V to VCC +1.0V	V
Storage Temperature	TSTG		-65 to +150	°C
Lead Temperature	TLEAD		See Note ⁽²⁾	°C
Electrostatic Discharge Voltage	VESD	Human Body Model ⁽³⁾	-2000 to +2000	V

Notes:

1. Stresses beyond those listed under "Absolute Maximum Ratings" may cause permanent damage to the device. The "Absolute Maximum Ratings" are stress ratings only and functional operation of the device at these or any other conditions beyond those indicated in the operational sections of this specification is not implied. Exposure to absolute maximum rating conditions for extended periods may affect device reliability. Voltage extremes referenced in the "Absolute Maximum Ratings" are intended to accommodate short duration undershoot/overshoot conditions and does not imply or guarantee functional device operation at these levels for any extended period of time.
2. Compliant with JEDEC Standard J-STD-20C for small body Sn-Pb or Pb-free (Green) assembly and the European directive on restrictions on hazardous substances (RoHS) 2002/95/EU.
3. JEDEC Std JESD22-A114A (C1=100pF, R1=1500 ohms, R2=500 ohms).

8.2 Operating Ranges

Parameter	Symbol	Conditions	Min	Max	Units
Erase/Program Cycles	VCC	FR = 104 MHz (Single/Dual/Quad SPI) fR = 50 MHz (Read Data 03h)	2.7	3.6	V
Ambient Operating Temperature	T _A	Industrial	-40	+85	°C

8.3 Endurance and Data Retention

Parameter	Symbol	Conditions	Min	Units
Erase/Program Cycles	4 KB Block, 32/64 KB block, or full chip.	100,000		Cycles
Data Retention	Full temperature range		20	years

8.4 Power-up Timing and Write Inhibit Threshold

Parameter	Symbol	Min	Max	Units
VCC (min) to \overline{CS} Low	$t_{VSL}^{(1)}$	10		μs
Time Delay Before Write Instruction	$t_{PUW}^{(1)}$	1	10	ms
Write Inhibit Threshold Voltage	VWI ⁽¹⁾	1.0	2.3	V

Note:

1. These parameters are characterized only.

Figure 8-1. Power-up Timing and Voltage Levels

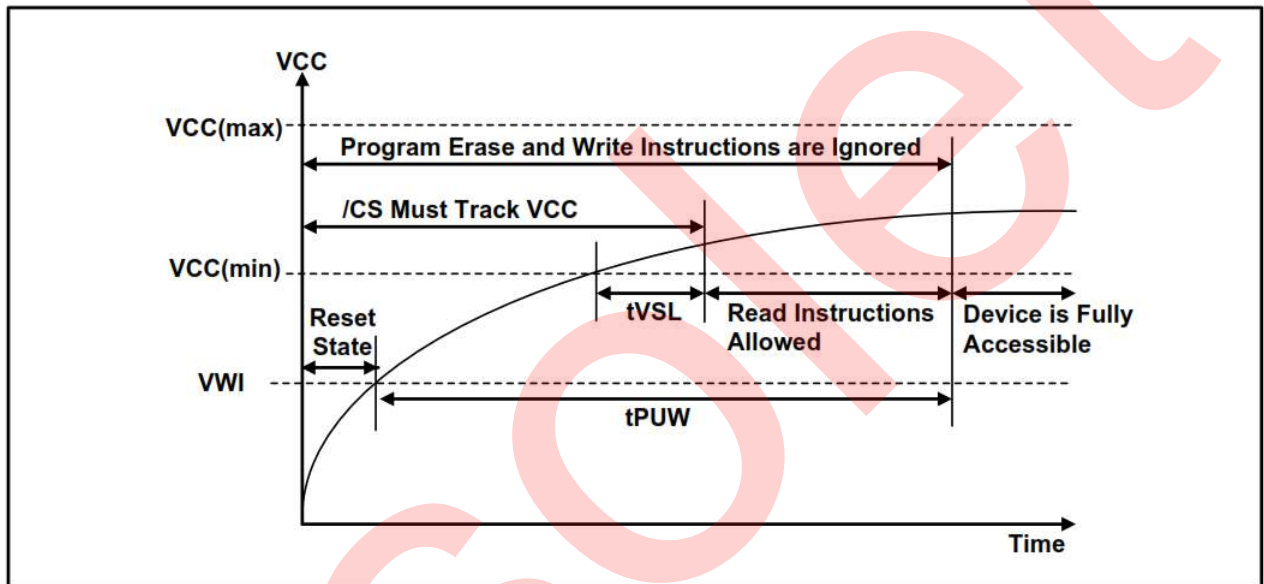

8.5 DC Electrical Characteristics

Parameter	Symbol	Conditions	Min	Typ	Max	Units
Input Capacitance	$C_{IN}^{(1)}$	$V_{IN} = 0V^{(2)}$			6	pF
Output Capacitance	$C_{OUT}^{(1)}$	$V_{OUT} = 0V^{(2)}$			8	pF
Input Leakage	ILI				± 2	μA
I/O Leakage	ILO				± 2	μA
Standby Current	ICC1	$\overline{CS} = VCC$ $V_{IN} = GND$ or VCC		10	50	μA
Power Down Current	ICC2	$\overline{CS} = VCC$ $V_{IN} = GND$ or VCC		2		μA
Current Read Data/ Dual/Quad 1MHz ⁽²⁾	ICC3	$C = 0.1 VCC / 0.9VCC$ IO = Open			7	mA

8.5 DC Electrical Characteristics (Continued)

Parameter	Symbol	Conditions	Min	Typ	Max	Units
Current Read Data/ Dual/Quad 50MHz ⁽²⁾	ICC3	C = 0.1 VCC / 0.9VCC IO = Open			15	mA
Current Read Data/ Dual/Quad 80MHz ⁽²⁾	ICC3	C = 0.1 VCC / 0.9VCC IO = Open			18	mA
Current Read Data/ Dual/Quad 104MHz ⁽²⁾	ICC3	C = 0.1 VCC / 0.9VCC IO = Open			25	mA
Current Write Status Register	ICC4	$\overline{CS} = VCC$		10	20	mA
Current page Program	ICC5	$\overline{CS} = VCC$		15	25	mA
Current Block Erase	ICC6	$\overline{CS} = VCC$		15	25	mA
Current Chip Erase	ICC7	$\overline{CS} = VCC$		15	25	mA
Input Low Voltage	VIL		-0.5		VCC x0.2	V
Input High Voltage	VIH		VCC x0.8		VCC +0.4	V
Output Low Voltage	VOL	IOL = 100 μ A			0.2	V
Output High Voltage	VOH	IOH = -100 μ A	VCC -0.2			V

Notes:

1. Tested on sample basis and specified through design and characterization data, TA = 25°C, VCC = 1.8V.
2. Checkerboard pattern.

8.6 AC Measurement Conditions

Parameter	Symbol	Min	Max	Units
Load Capacitance	CL		30	pF
Input Rise and Fall Times	TR, TF		5	ns
Input Pulse Voltages	VIN	0.2 VCC to 0.8 VCC		V
Input Timing Reference Voltages	IN	0.3 VCC to 0.7 VCC		V
Output Timing Reference Voltages	OUT	0.5 VCC to 0.5 VCC		V

Note:

1. Output Hi-Z is defined as the point where data out is no longer driven

Figure 8-2. AC Measurement I/O Waveform

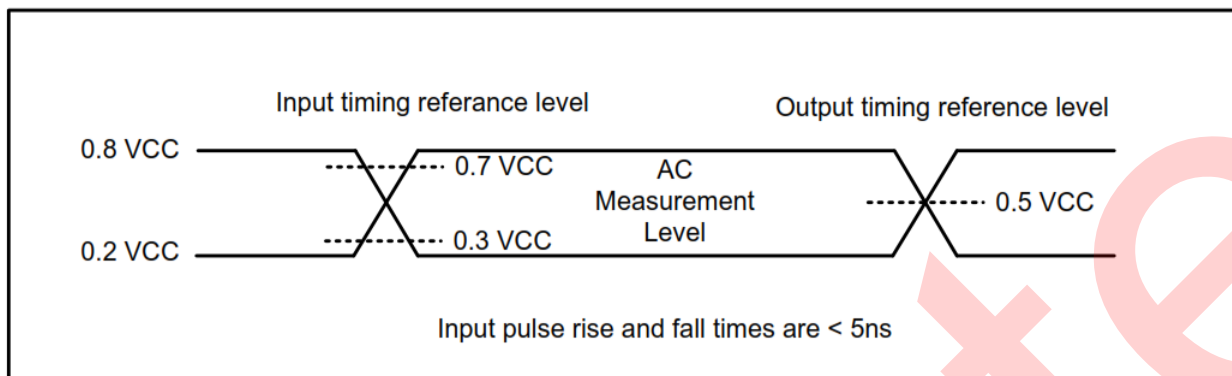

8.7 AC Electrical Characteristics

Parameter	Symbol	Alt	Min	Typ	Max	Units
Clock frequency for all instructions, except Read Data (03h) 1.65V-1.95V VCC and Industrial Temperature	f_R	f_c	D.C.		104 ⁽⁶⁾	MHz
Clock freq. Read Data instruction (03h)	f_R		D.C.		50	MHz
Clock High, Low Time except Read Data (03h)	t_{CLH} , $t_{CLL}^{(1)}$		3.5			ns
Clock High, Low Time for Read Data (03h) instructions	t_{CRLH} , $t_{CRLL}^{(1)}$		8			ns
Clock Rise Time peak to peak	$t_{CLCH}^{(2)}$		0.1			V/ns
Clock Fall Time peak to peak	$t_{CHCL}^{(2)}$		0.1			V/ns
\overline{CS} Active Setup Time relative to Clock	t_{SLCH}	t_{CSS}	5			ns
\overline{CS} Not Active Hold Time relative to Clock	t_{CHSL}		5			ns
Data In Setup Time	t_{DVCH}	t_{DSU}	2			ns
Data In Hold Time	t_{CHDX}	t_{DH}	3			ns
\overline{CS} Active Hold Time relative to Clock	t_{CHSH}		5			ns
\overline{CS} Not Active Setup Time relative to Clock	t_{SHCH}		5			ns
\overline{CS} Deselect Time (for Read instructions/ Write, Erase and Program instructions)	t_{SHSL}	t_{CSH}	30			ns
Output Disable Time	$t_{SHQZ}^{(2)}$	t_{DIS}			7	ns
Clock Low to Output Valid	t_{CLQV}	t_{V1}			6	ns
Clock Low to Output Valid (Except Main Read) ⁽³⁾	t_{CLQV}	t_{V2}			7	ns
Output Hold Time	t_{CLQX}	t_{HO}	1.5			ns
\overline{HOLD} Active Setup Time relative to Clock	t_{HLCH}		5			ns

8.7 AC Electrical Characteristics (Continued)

Parameter	Symbol	Alt	Min	Typ	Max	Units
$\overline{\text{HOLD}}$ Active Hold Time relative to Clock	t_{CHHH}		5			ns
$\overline{\text{HOLD}}$ Not Active Setup Time relative to Clock	t_{HHCH}		5			ns
$\overline{\text{HOLD}}$ Not Active Hold Time relative to Clock	t_{CHHL}		5			ns
$\overline{\text{HOLD}}$ to Output Low-Z	$t_{\text{HHQX}}^{(2)}$	t_{LZ}			7	ns
$\overline{\text{HOLD}}$ to Output High-Z	$t_{\text{HLQZ}}^{(2)}$	t_{HZ}			12	ns
Write Protect Setup Time Before $\overline{\text{CS}}$ Low	$t_{\text{WHSL}}^{(4)}$		20			ns
Write Protect Setup Time After $\overline{\text{CS}}$ High	$t_{\text{SHWL}}^{(4)}$		100			ns
$\overline{\text{CS}}$ High to Power Down Mode	$t_{\text{DP}}^{(2)}$				3	μs
$\overline{\text{CS}}$ High to Standby Mode without Electronic Signature Read	$t_{\text{RES1}}^{(2)}$				3	μs
$\overline{\text{CS}}$ High to Standby Mode with Electronic Signature Read	$t_{\text{RES2}}^{(2)}$				1.8	μs
$\overline{\text{CS}}$ High to next Instruction after Suspend	$t_{\text{SUS}}^{(2)}$				30	μs
$\overline{\text{CS}}$ High to next Instruction after Reset	$t_{\text{RST}}^{(2)}$				30	μs
Write Status Register Time	t_{W}			5	15	ms
Byte Program Time	t_{BP}			5	150	μs
Page Program Time	t_{PP}			0.6	5	ms
Block Erase Time (4KB)	t_{SE}			0.06	0.4	s
Block Erase Time (32KB)	t_{BE1}			0.35	1.5	s
Block Erase Time (64KB)	t_{BE2}			0.7	2	s
Chip Erase Time	t_{CE}			80	150	s

Notes:

1. Clock high + Clock low must be less than or equal to $1/f_c$.
2. Value guaranteed by design and/or characterization, not 100% tested in production.
3. Contains: Read Status Register-1,2/ Read Manufacturer/Device ID, Dual, Quad/ Read JEDEC ID/ Read Security Register/ Read Serial Flash Discovery Parameter.
4. Only applicable as a constraint for a Write Status Register instruction when Sector Protect Bit is set to 1.
5. Commercial temperature only applies to Fast Read (FR). Industrial temperature applies to all other parameters.

8.8 Input Timing

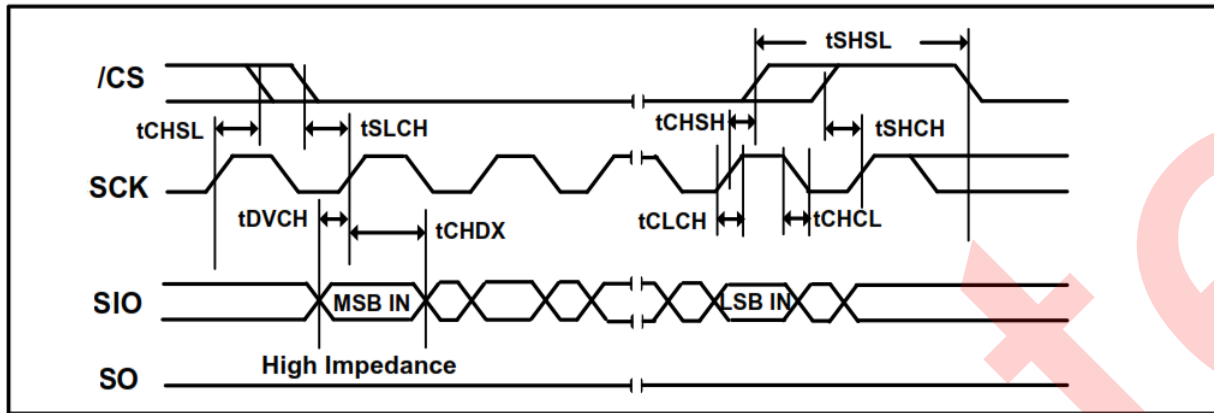

8.9 Output Timing

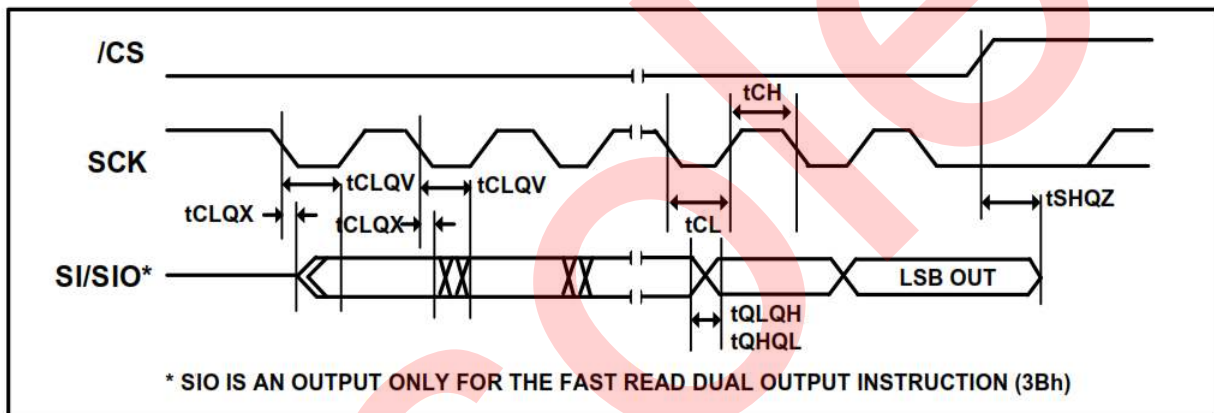

8.10 Hold Timing

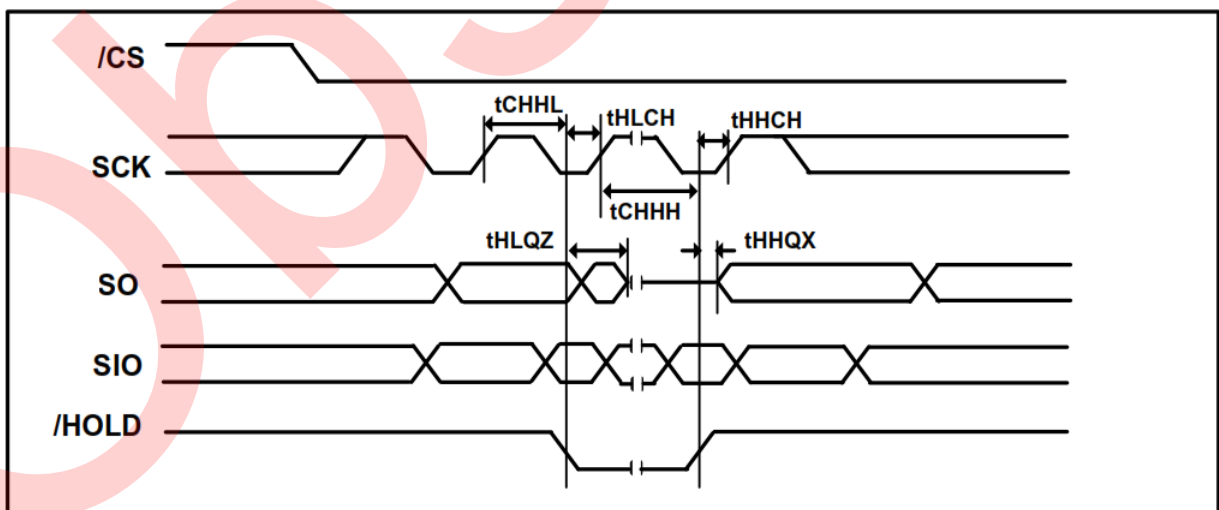

9. Ordering Information

9.1 Ordering Code Detail

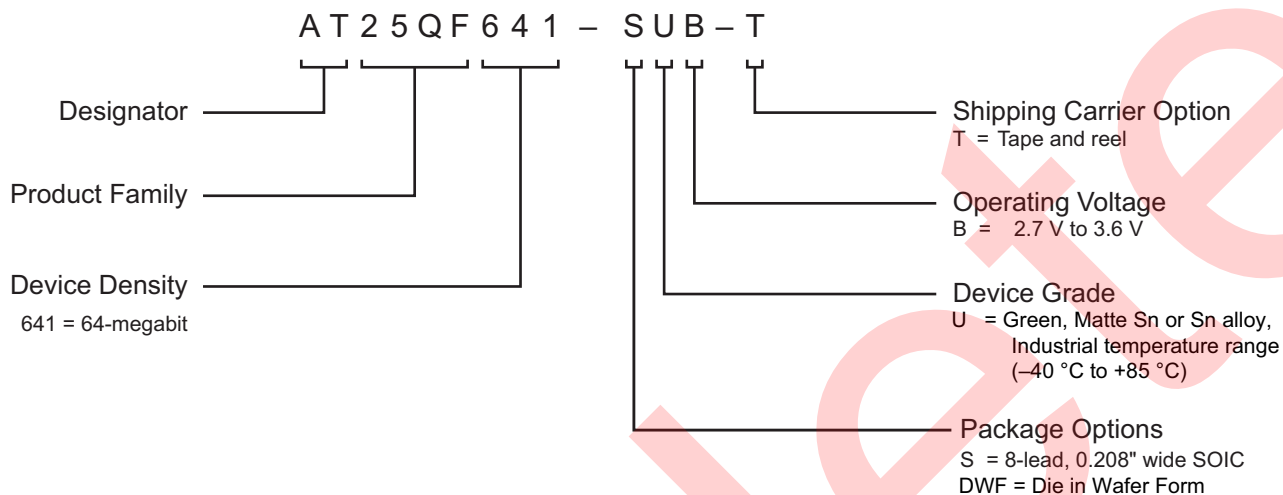

Ordering Code ⁽¹⁾	Lead Finish	Operating Voltage	Max. Freq. (MHz)	Operation Range
AT25QF641-SUB-T	SnAgCu	2.7V - 3.6V	104 MHz	-40 °C to 85 °C
AT25QF641-DWF ⁽²⁾				(Industrial Temperature Range)

1. The shipping carrier option code is not marked on the devices.
2. Contact Renesas Electronics for mechanical drawing or sales information.

Package Description
8-lead, 0.208" Wide, Plastic Gull Wing Small Outline Package (EIAJ SOIC)
Die in Wafer Form

10. Packaging Information

10.1 8-Lead, 0.208" EIAJ SOIC

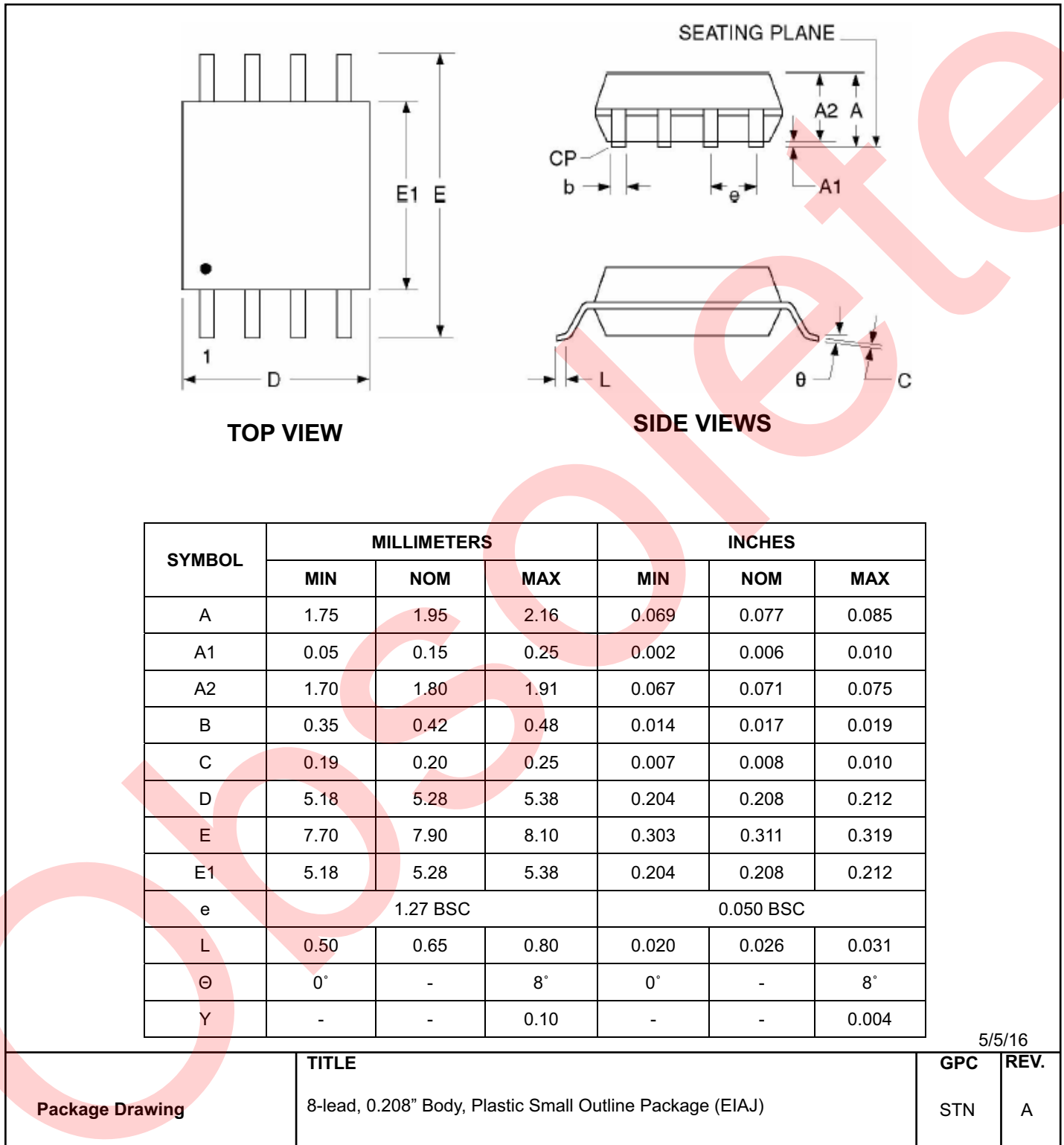

11. Revision History

Revision	Date	Change History
A	11/2016	Initial release of AT25QF641 data sheet.
B	02/2017	Updated Note 1 on Table 8.1.
C	05/2017	Added clarification to Write Status Register (01h) description. Updated document status from Advanced to Complete.
D	11/2017	Removed references to 133 MHz. Removed 18- and 24-ball packages. Added Errata related to Write Status Register command (section 7.6).
E	03/2018	Removed WLCSP package. Removed UDFN package. Updated Block and Chip erase times in AC Electrical Characteristics table.
F	6/2022	Technical edit of entire document. Updated text of each instruction accordingly. Added subscript and superscript text as necessary. Updated Figure 7-50, Word Read Quad I/O. Removed reference to UDFN package on page 1. Updated text in Section 4.3, Quad SPI Operation. Updated text in Section 4.4, QPI Operation. Updated text in Section 6.7, Quad Enable. Updated text in Section 7.25, Manufacturer Device ID (90h). Updated text in Section 7.26, Manufacturer Device ID Dual I/O (92h). Updated text in Section 7.27, Manufacturer Device ID Quad I/O (94h). Formatted all SFDP tables in Section 7.36. Updated all references to Section 8.7, AC Electrical Characteristics throughout entire document. Updated legal notice on last page of document. Changed company logo to Renesas. Added Appendix A. Changed to new Adesto template. Added to front page: NOT RECOMMENDED FOR NEW DESIGNS. Use AT25QF641B.
G	6/2023	Document marked "Obsolete."

Appendix A. Effect of Excessive Number of \overline{CS} Toggle Operations

The purpose of this appendix is to describe the possible undesirable side-effects of excessive number of \overline{CS} toggle on AT25QF641 Flash device. The descriptions included in this document pertain to the AT25QF641 device only. No other devices are affected by this phenomenon.

Also provided are some design techniques and recommendations for extending the lifetime of the device under high-stress conditions, such as an unusually high number of \overline{CS} toggles.

The number of read operations is practically unlimited, provided the number of \overline{CS} toggle cycles remains under 3.65 billion over 10 years. This corresponds to about 1,000,000 \overline{CS} toggles a day. Each time the \overline{CS} signal goes active (low voltage level), certain configuration cells are exercised for active device operation. Excessive configurations can progressively disturb these cells and may result in incorrect read operation of the Flash memory.

Once \overline{CS} is active, there are no limitations on how many bytes of data can be read from the device. To extend the lifetime of the device to beyond 10 years, it is important to keep the number of times \overline{CS} is toggled below 1,000,000 cycles a day. This can be achieved, by:

- Reducing the number of memory accesses
- Minimizing the number of \overline{CS} toggles, but reading larger sections of the memory at once, rather than accessing the memory frequently and reading small chunks of data