

REVISONS			
LET	ECN	DESCRIPTION	DATE
01		INITIAL RELEASE	04-08-12 Janves
02		ADDED CAVITY ID	05-22-12 JMM

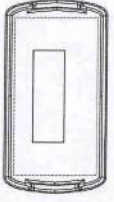

SCALE 1/1

NOTES:

- FOR LIST OF MATERIAL SEE:
PL 115126-501, 115127-501
- UNLESS OTHERWISE SPECIFIED:
CORNERS SHOWN SHARP HAVE
A RADIUS OF .01.
- NO KNOCKOUTS, GATES OR FLASH
ON THE EXTERIOR SURFACES.
- FLASH PERMISSIBLE WITHIN .005 INCH.
- KNOCKOUTS FLUSH TO .005 BELOW SURFACE.
- TEXTURE: EDM #33
- INTERIOR FINISH: SPI C3 OR BETTER
- FOR ALL OTHER DIMENSIONS,
SEE DRAWING: 115119-01

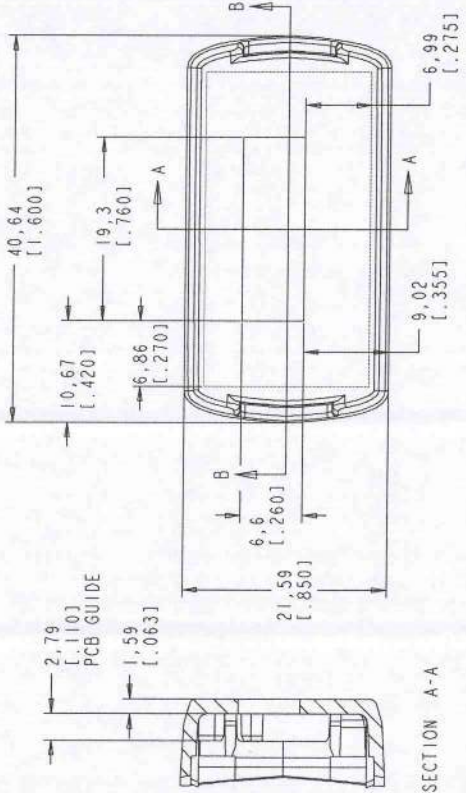
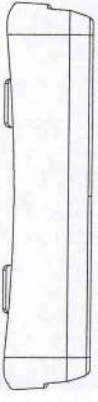
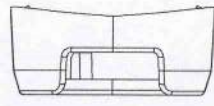
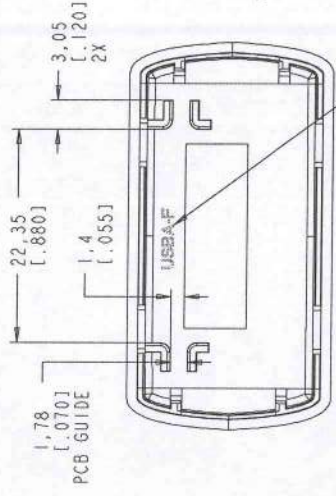

SECTION A-A

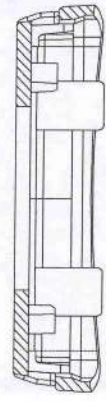

SECTION B-B

PACINTEC
 Subsidiary of LaFrance Corp.

1111 S. 33RD, PHOENIX, AZ 85004
 602-998-8888

MOLDING TOLERANCE:
 PRODUCT WILL BE PRODUCED
 PER SPI-SPE INSTITUTE
 PRODUCT STANDARDS
 AND TOLERANCES

MATERIAL:
 MECHANICAL:
 ANGLES:
 DECIMALS:
 .XXX ±.010

NAME	DATE
DRAWN: Janves	04-08-12
CHECK: Ted	04-08-12
APPROVE: JMM	04-23-12

MATERIAL:
COLOR: SEE PARTS LIST
CLASS:

PROCESS:	SCALE:	SHEET 1 OF 1
INJ MOLDED	2:1	
PART #	DRAWING NUMBER	REV
115116-01	115116-01	02