

## Specification

### 10G Ethernet Optical Bypass Module

#### Dual Ports 10G Base-LR

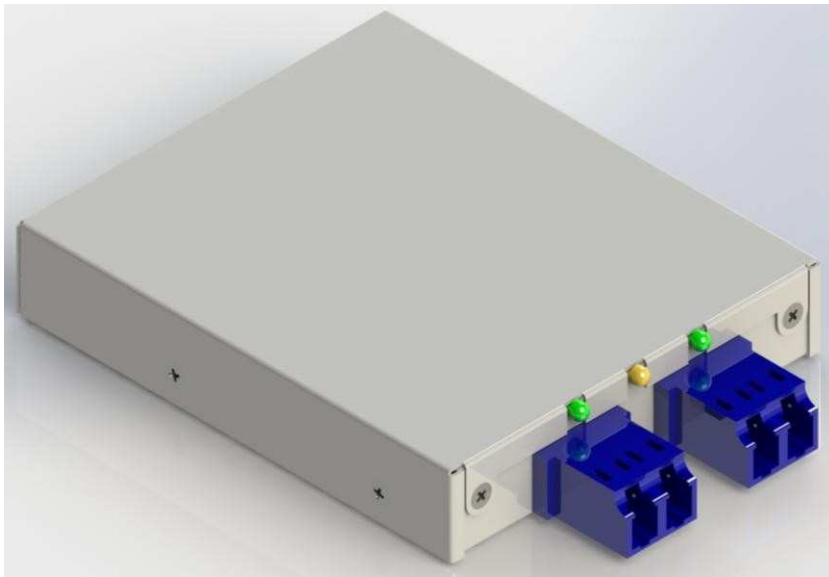

**O B M -A3CB2-C06\_V3**

## Product Overview

FormericaOE Dual Port 10 Gbit/s Optical Bypass Module is a compact box that contains two 10 G Base-LR1310nm (10KM) ports and can be integrated with I/O ports controllers to be a Network Interface Card (NIC). The FormericaOE Dual Port 10 Gbit/s Optical Bypass Module is targeted to inline network system that maintains network connectivity when power failure or system fails. FormericaOE Dual Port 10 Gbit/s Optical Bypass Module supports Normal and Bypass modes, and can be controlled to perform the Block mode. In Normal mode, the ports are independent interfaces. In Bypass mode, all packets received from one port are transmitted to the adjacent port. In Block mode, the module blocks the route. FormericaOE Dual Port 10 Gbit/s Optical Bypass Module can Bypass or Block its I/O ports on a host system failure, power off, or upon software request. FormericaOE Dual Port 10 Gbit/s Optical Bypass Module can be integrated with any brand's Controllers CPU. It is suitable for connecting with in-line equipment's for power failure or system maintenance. When the In-Line unit is not on or is in bypass mode, the relays within the Optical Bypass Module are set to bridge the optical signals directly through the optical switch, completely bypassing the In-Line equipment. If the In-Line equipment is on and operating normally, then it supplies power to the switch through a high speed connector PIN. Compact and competitive cost, this module provides excellent performance on your network.

## Features

- Reliable Passive Fiber Bypass (Latching)
- Low Return Loss
- Available in 9/125µm Single mode Fiber
- PCB Mountable Type
- Fast Ethernet Standard Compliant
- Digital Diagnostic SFF-8472 Rev.10.2 Compliant
- SONET/SDH Standard Compliant
- Two Dual LC Adapter
- Class 1 Laser Product Complies with EN 60825-1
- 10G-BASE-LR are available
- Compliant with CE& FCC Standard
- Compact Format and ROHS Compliant

Block Diagram and Optical Paths

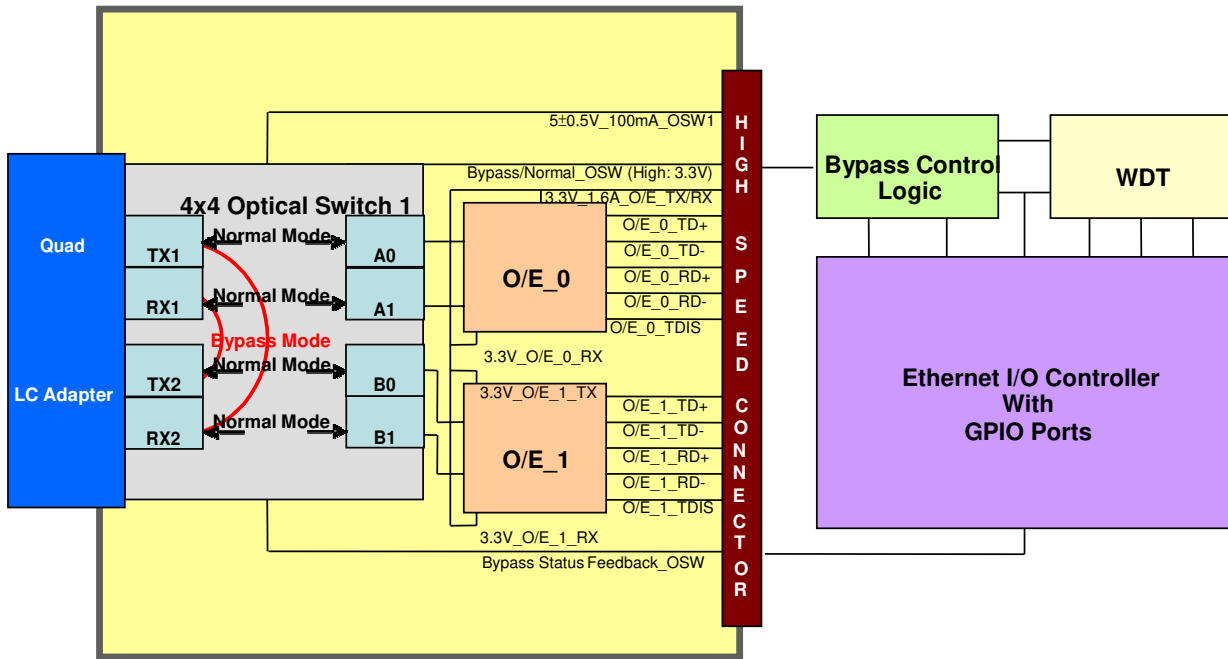

Dual Ports Optical Bypass Module

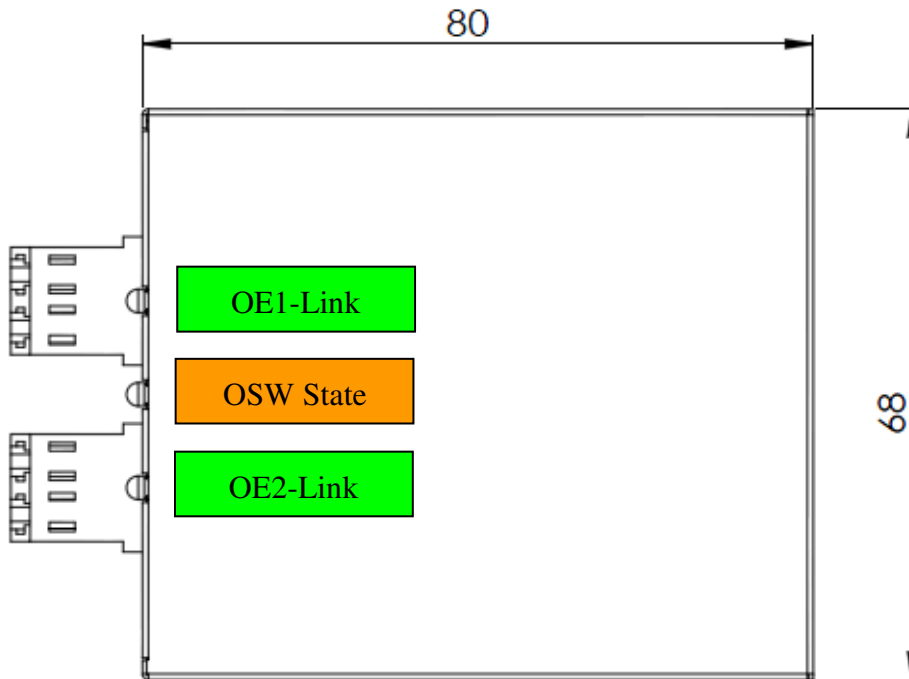

- OE1-Link and OE2-Link indications:  
**Green:** Link
- OSW State indications:  
**Amber:** Optical Switch State

Module Pin Out

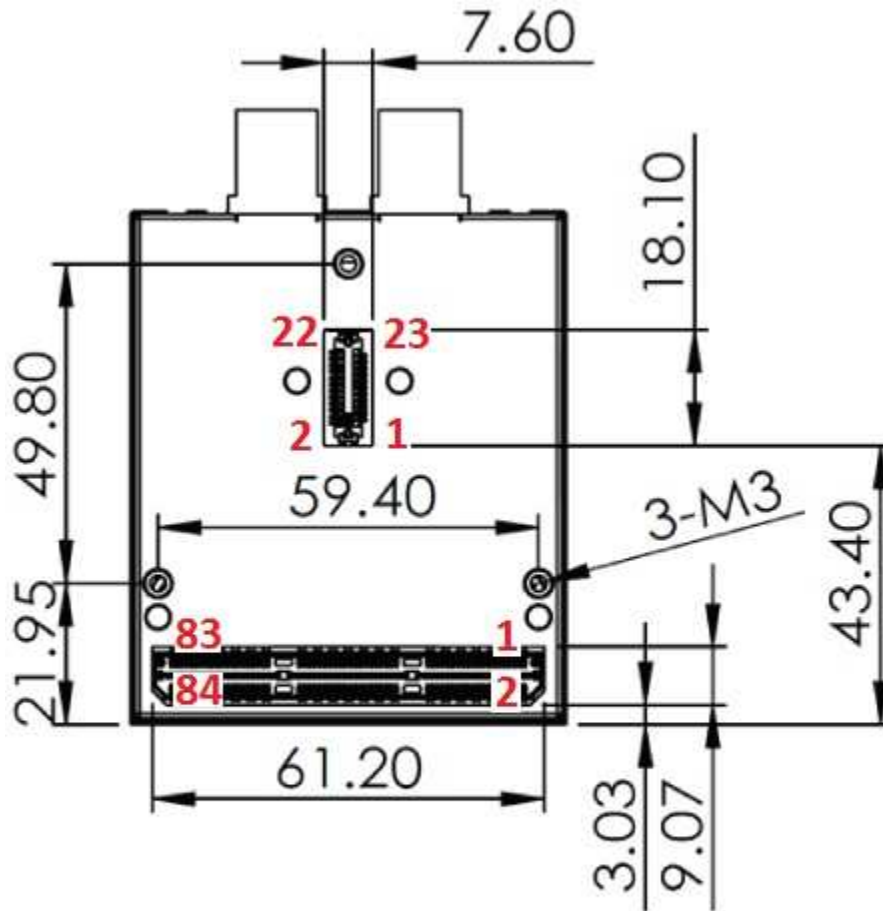

**84 PIN Assignments:**

Pin Number	Name	I/O	Function	Note
1				
2				
3				
4	GND			
5				
6	On-Line	O	1K Ohm to Ground	
7	OE1 GND		OE1 Signal Ground	
8	GND			
9	OE1 TD-	I	OE1 Inversed Data Input	6
10	OE1 TX Disable	I	Transmitter Disable for OE-1	2
11	OE1 TD+	I	OE1 Data Input	6
12	OE1 TX Fault	O	Transmitter Fault Indication for OE-1	1
13	OE1 GND		OE1 Signal Ground	
14	OE1 MOD-DEF2	I/O	2 Wire Serial ID Interface (Data) for OE-1	3
15	OE1 GND		OE1 Signal Ground	
16	OE1 MOD-DEF1	I	2 Wire Serial ID Interface (Clock) for OE-1	3
17	OE1 RD+	O	OE1 Data Output	5
18	OE1 Vcc		3.3V for Tx1 Power Supply and Rx1 Power Supply – 300mA	
19	OE1 RD-	O	OE1 Inversed Data Output	5
20	OE1-Link	I	OE1-Link LED Indicator (Anode/ LED Green)	
21	OE1 GND		OE1 Signal Ground	
22	OSW 1 State	I	OSW 1 State LED Indicator (Anode / LED Amber)	
23	OE1 LOS	O	Loss of Signal for OE-1	4
24	OE1 Rate Select	I	High: 10 Gbps; Low: 1.25Gbps	
25				
26	GND			
27				
28				
29				
30				
31				
32				
33				
34				
35				
36				
37				
38				
39				
40				
41				
42				
43	OE2 GND		OE2 Signal Ground	
44	GND			
45	OE2 TD-	I	OE2 Inversed Data Input	
46	OE2 TX Disable	I	Transmitter Disable for OE-2	2
47	OE2 TD+	I	OE2 Data Input	6
48	OE2 TX Fault	O	Transmitter Fault Indication for OE-2	1
49	OE2 GND		OE2 Signal Ground	6
50	OE2 MOD-DEF2	I/O	2 Wire Serial ID Interface (Data) for OE-2	3
51	OE2 GND		OE2 Signal Ground	
52	OE2 MOD-DEF1	I	2 Wire Serial ID Interface (Clock) for OE-2	3

Pin Number	Name	I/O	Function	Note
52	OE2 RD+	O	OE2 Data Output	5
54	OE2 Vcc		3.3V for Tx2 Power Supply and Rx2 Power Supply – 300mA	
55	OE2 RD-	O	OE2 Inversed Data Output	5
56	OE2-Link	I	OE2-Link LED indicator (Anode / LED Green)	
57	OE2 GND		OE2 Signal Ground	
58	LED-pair1 common	I	LED-pair1 common Cathode	
59	OE2 LOS	O	Loss of Signal for OE-2	4
60	OE2 Rate Select	I	High: 10 Gbps; Low: 1.25Gbps	
61				
62	GND			
63				
64				
65				
66				
67				
68				
69				
70				
71				
72				
73				
74				
75				
76				
77				
78				
79	OSW 1 State Output	O	High=Normal Mode. Low=Bypass Mode for OSW1	
80	GND			
81	OSW 1 B1	I	Change to Bypass mode for OSW1	7/9
82	GND			
83	OSW 1 N1	I	Change to Normal mode for OSW1	7/9
84	Vcc5_1		5.0V Power Supply (OSW 1 Power)	8

**PIN Assignments of 23 pins Connector:**

Pin Number	Name	I/O	Function	Note
1	Vcc5_1		5.0V Power Supper (OSW1 Power)	
2	Vcc5_1		5.0V Power Supper (OSW1 Power)	
3			No Connector	
4	OE1-Link	I	OE1-Link LED Indicator (Anode/ LED Green)	
5			No Connector	
6	OSW 1 State	I	OSW 1 State LED Indicator (Anode / LED Amber)	
7			No Connector	
8	OE2-Link	I	OE2-Link LED indicator (Anode / LED Green)	
9			No Connector	
10	LED-pair1 common	I	LED-pair1 common Cathode	
11			No Connector	
12	OSW 1 State Output	O	High=Normal Mode, Low=Bypass Mode for OSW1	
13	GND			
14	GND			
15			No Connector	
16	OSW 1 B1	I	Change to Bypass mode for OSW1	
17			No Connector	
18	OSW 1 N1	I	Change to Normal mode for OSW1	
19			No Connector	
20			No Connector	
21			No Connector	
22			No Connector	
23			No Connector	

**Notes:**

1. TX Fault is an open collector/drain output, which should be pulled up with a 4.7K – 10K $\Omega$  resistor on the hostboard. Pull up voltage between 2.0V and VccT, R+0.3V. When high, output indicates a laser fault of some kind. Low indicates normal operation. In the low state, the output will be pulled to <0.5V.
2. TX disable is an input that is used to shut down the transmitter optical output. It is pulled up within the module with a 4.7 – 10 K  $\Omega$  resistor. Its states are:
  - ◆ Low (0 – 0.8V): Transmitter on
  - ◆ (>0.8, < 2.0V): Undefined
  - ◆ High (2.0 – 3.465V): Transmitter Disabled
  - ◆ Open: Transmitter Disabled
3. Mod-Def 1,2, These are the module definition pins. They should be pulled up with a 4.7K – 10K $\Omega$  resistor on the host board. The pull-up voltage shall be VccT or VccR (see Section IV for further details). Mod-Def 0 is grounded by the module to indicate that the module is present Mod-Def 1 is the clock line of two wire serial interface for serial ID Mod-Def 2 is the data line of two wire serial interface for serial ID
4. LOS (Loss of Signal) is an open collector/drain output, which should be pulled up with a 4.7K – 10K $\Omega$  resistor. Pull up voltage between 2.0V and VccT, R+0.3V. When high, this output indicates the received optical power is below the worst-case receiver sensitivity (as defined by the standard in use). Low indicates normal operation. In the low state, the output will be pulled to < 0.5V.
5. RD-/+ : These are the differential receiver outputs. They are AC coupled 100 $\Omega$  differential lines which should be terminated with 100 $\Omega$  (differential) at the user SERDES. The AC coupling is done inside the module and is thus not required on the host board. The voltage swing on these lines will be between 350 and 850 mV differential (175 – 425 mV single ended) when properly terminated.
6. TD-/+ : These are the differential transmitter inputs. They are AC-coupled, differential lines with 100 $\Omega$  differential termination inside the module. The AC coupling is done inside the module and is thus not required on the host board. The inputs will accept differential swings of 180 – 700 mV (90 – 350 mV single-ended).
7. Latching Type - The input is used to control the optical switch mode for OSW
  - ◆ Normal mode:
    - OSW N1/N2: > 3.75V and OSW B1/B2 < 0.5V and over 20ms.
  - ◆ Bypass mode:
    - OSW N1/N2: < 0.5V and OSW B1/B2 > 3.75V and over 20ms
8. Non-Latching Type - High = Normal Mode, Low = Bypass Mode for OSW.
9. Non-Latching Type - Pin 43, 44, 82 and 83: Ground



### Absolute Maximu Ratings

Parameter	Symbol	Min.	Typ.	Max.	Unit
Power Supply Voltage	Vcc	0		3.6	V
Storage Temperature	Ts	-40		85	°C
Supply Voltage	Vcc	0		5	V
Optical Receiver Power (Damage)	Pmax			15	dBm

### Recommended Operating Conditions

Parameter	Symbol	Min.	Typ.	Max.	Unit	Note
Case Operating Temperature	Tc	0		70	°C	1
+5.0V Supply Voltage	Vcc5	4.75		5.25	V	Vcc5
+3.3V Supply Voltage	Vcc3	3.10		3.50	V	
Relative Humidity (non condensation)		5		85	%	
Data Rate		-100ppm	10.3125	+100ppm	Gbps	

Note1 : Please see order information

### Electrical Characteristics

Parameter	Symbol	Min.	Typ.	Max.	Unit	Note
+5.0V Supply Current	Icc5			100	mA	
+3.3V Supply Current	Icc3			1200	mA	
Data Rate		-	10.3125	-	Gbps	
<b>Transmitter</b>						
Transmitter Differential Input Voltage	V <sub>DT</sub>	180		700	mV	1
Transmitter Disable Input-High	V <sub>DISH</sub>	2		Vcc+0.3	V	
Transmitter Disable Input-Low	V <sub>DISL</sub>	0		0.8	V	
<b>Receiver</b>						
Receiver Differential Output Voltage	V <sub>DR</sub>	350		850	mV	3
LOS Output Voltage-High	V <sub>LOSH</sub>	2.4		Vcc	V	2
LOS Output Voltage-Low	V <sub>LOSL</sub>	0		0.5	V	2
<b>Optical Switch</b>						
Latching Voltage-High	V <sub>LATH</sub>	4.75	5	5.25	V	
Latching Voltage-Low	V <sub>LATL</sub>	0		0.8	V	
Latching Resistance	R <sub>LAT</sub>		125		Ω	

#### Notes:

1. Internally AC coupled and terminated to 100Ohm differential load.
2. Pull up to Vcc on Host Board.
3. Internally AC coupled, but requies a 100Ohm differential termination at or internal to Serializer/Deserializer.

**Optical Characteristics**(Tc=0~70°C, Data Rate=10.3125Gb/sec, PRBS=2<sup>31</sup>-1 NRZ)

Parameter	Symbol	Min.	Typ.	Max.	Unit	Note
<b>Transmitter</b>						
Average Launch Power	P <sub>o</sub>	-8.2		0.5	dBm	
Center Wavelength	$\lambda_c$	1260		1355	nm	
Side Mode Suppression Ratio	SMSR	30	--	--	nm	
Extinction Ratio	E <sub>R</sub>	3.5	--	--	dB	
Transmitter and dispersion penalty(max)	TDP	--	--	3.2	dB	
Optical Power OMA	P <sub>OMA</sub>	-5.2	--	--	dBm	
OMA-TDP	P <sub>OMA-TDP</sub>	-6.2	--	--	dBm	
Average launch power of OFF transmitted	P <sub>off</sub>	--	--	-128	dB/Hz	
Optical Return Loss Tolerance		12	--	--	dB	
Output eye	Compliant with IEEE802.3ae eye mask					
<b>Receiver</b>						
Center Wavelength	$\lambda_c$	1260		1355	Nm	
Average receiver power(max)	P <sub>max</sub>			0.5	dBm	
Average receiver power(min)	P <sub>min</sub>	-14.4			dBm	
Receiver Reflectance	R <sub>rx</sub>			-12	dB	
Receiver Sensitivity in OMA				-12.6	dBm	
Stressed Sensitivity in OMA				-10.3	dBm	1
Vertical eye closure penalty		2.2			dB	2
Stressed eye jitter		0.3			UI <sub>p-p</sub>	1
LOS	Assert	LOS <sub>A</sub>	-30		dBm	
	Deassert	LOS <sub>D</sub>		-12	dBm	
LOS Hysteresis	LOS <sub>H</sub>	0.5				
<b>Optical Switch</b>						
Wavelength Range	$\lambda_R$	1260~1360 and 1510~1610			nm	
Insertion Loss	OIL			2	dB	
Return Loss	ORL	50			dB	
Switch Time				8	ms	
Lifetime			$\geq 10^7$		times	
Latching Resistance	R <sub>LAT</sub>		125		$\Omega$	

**Notes:**

1. Receiver Sensitivity is informative. Stressed receiver sensitivity shall be measured with conformance test signal for BER  $1 \times 10^{-12}$
2. Vertical eye closure penalty and stressed eye jitter are the test conditions for measuring stressed receiver sensitivity. They are not the required characteristic of the receiver.

Package Outline Drawing (mm)

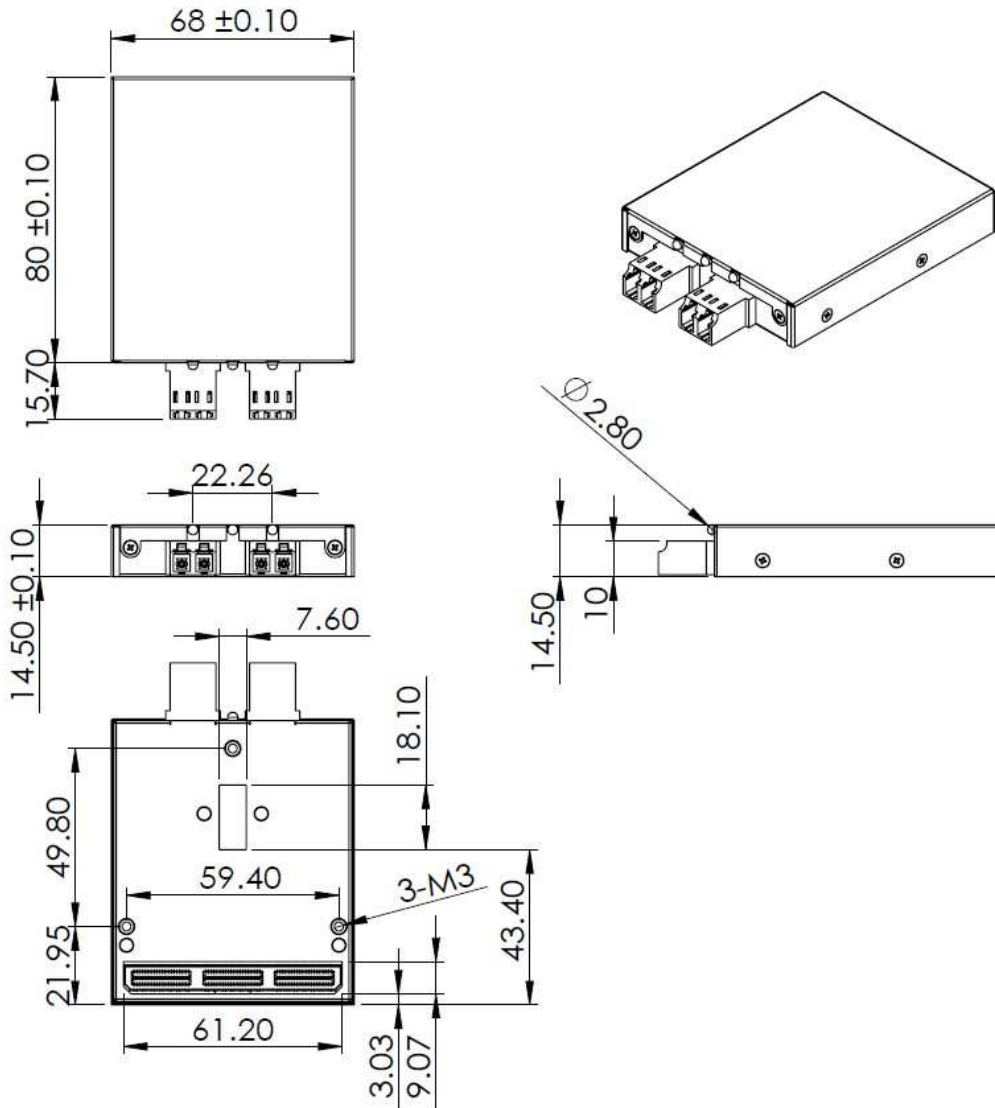

**Host Board B2B Connector**

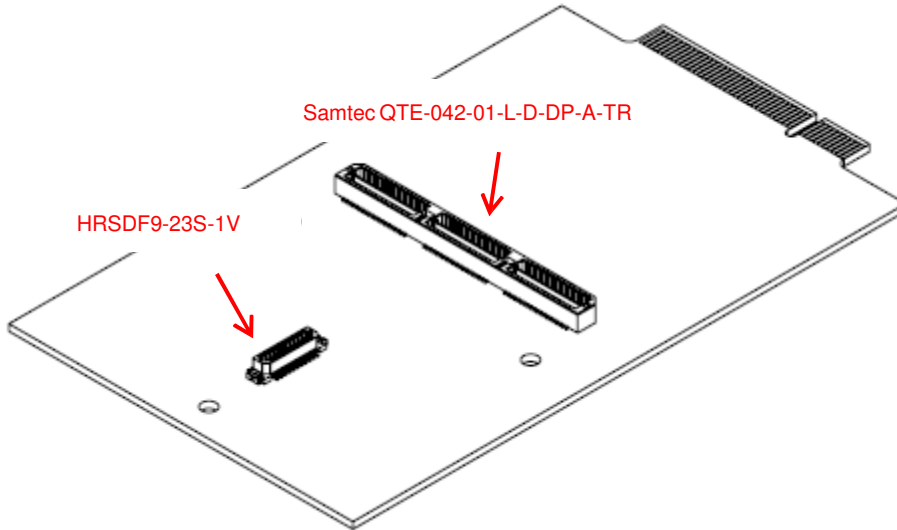

**Customer Host Board Top View**

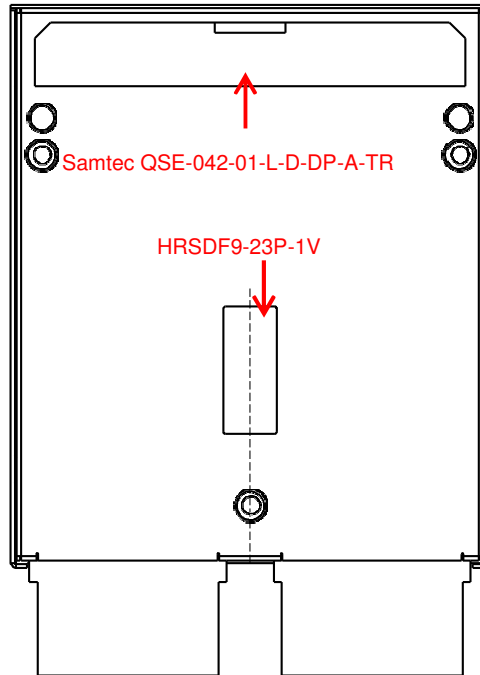

**Fiber Bypass Module: Bottom View**

**EEPROM Serial ID Memory Contents (2-Wire Address A0H)**

Address	HEX	Name of Field	Description
00	03	Identifier	SFP
01	04	Extended Identifier	SFP
02	07	Connector type	LC
03	20	10G Ethernet Compliance Codes	10G Base LR
04	00	SONET Compliance Codes	Not compliant
05	00	SONET Compliance Codes	Not compliant
06	00	Ethernet Compliance Codes	Not compliant
07	00	Fiber Channel link length	Not compliant
08	00	Fiber Channel transmitter technology	Not compliant
09	00	Fiber Channel transmission media	Not compliant
10	00	Fiber Channel speed	Not compliant
11	06	Encoding codes:	64B/66B
12	67	Nominal Bit Rate (units of 100Mbps)	10.3Gbps
13	00	Rate identifier	Unspecified
14	0A	Link length supported for 9um fiber	10km (units of km)
15	64	Link length supported for 9um fiber	10km (units of 100m)
16	00	Link length supported for 50um,OM2	N/A (units of 10m)
17	00	Link length supported for 62.5um,OM1	N/A (units of 10m)
18	00	Link length supported for copper	N/A (units of 1m)
19	00	Link length supported for 50um,OM3	N/A (units of 10m)
20 ~ 35	46,4F,52,4D,45,52,49,43 ,41,4F,45,20,20,20,20,20	Vendor Name	FORMERICA OE
36	00	Unallocated	
37 ~ 39	00,00,00	Vendor OUI	Unspecified
40 ~ 55	4F,42,4D,2D,41,33,43,42,32,2D,43,30,36,5F,56,33	Part Number	OBM-A3CB2-C06_V3
56 ~ 59	00,00,00,00	Vendor Revision number	Unspecified
60 ~ 61	05,1E	Laser Wavelength	1310nm
62	00	Unallocated	
63		CC_BASE:	Check sum of byte 0 ~ 62
64	00	Options	
65	1A	Options	TX-DIS, TX_FAULT, RX-LOS
66	00	Bit Rate, max.	Unspecified
67	00	Bit Rate, min.	Unspecified
68 ~ 83	Serial Number	Serial Number	
84 ~ 89	yy/mm/dd	Date Code	
90 ~ 91	20,20	Vendor specific lot code	Unspecified
92	68	Diagnostic Monitoring Type	Internal calibration
93	F0	Enhanced Options (soft)	Alarm/Warning flags, Soft TxDisable, Soft TxFault, Soft RxLOS implemented
94	03	SFF-8472 Compliance	Rev10.2
95		CC_EXT	Check sum of byte 64 ~ 94
96~127		Vendor specific	

**EEPROM Serial ID Memory Contents (2-Wire Address A2H)**

Add	Bytes	Name	Hex	Real Value
00-01	2	Temp High Alarm	5500	85°C
02-03	2	Temp Low Alarm	0000	0°C
04-05	2	Temp High Warning	5000	80°C
06-07	2	Temp Low Warning	0A00	10°C
08-09	2	Voltage High Alarm	9470	3.8V
10-11	2	Voltage Low Alarm	6D60	2.8V
12-13	2	Voltage High Warning	9088	3.7V
14-15	2	Voltage Low Warning	7148	2.9V
16-17	2	Bias High Alarm	AFC8	90mA
18-19	2	Bias Low Alarm	03E8	2mA
20-21	2	Bias High Warning	9C40	80mA
22-23	2	Bias Low Warning	05DC	3mA
24-25	2	TX Power High Alarm	576C	3.5dBm
26-27	2	TX Power Low Alarm	02F8	-11.2dBm
28-29	2	TX Power High Warning	4574	2.5dBm
30-31	2	TX Power Low Warning	03B6	-10.2dBm
32-33	2	RX Power High Alarm	576C	3.5dBm
34-35	2	RX Power Low Alarm	00E6	-16.4dBm
36-37	2	RX Power High Warning	4574	2.5dBm
38-39	2	RX Power Low Warning	016B	-14.4dBm
40-55	16	Reserved	00	-
56-59	4	RX_PWR(4)	00000000	0
60-63	4	RX_PWR(3)	00000000	0
64-67	4	RX_PWR(2)	00000000	0
68-71	4	RX_PWR(1)	3F800000	1
72-75	4	RX_PWR(0)	00000000	0
76-77	2	TX_I(Slope)	0100	1
78-79	2	TX_I(Offset)	0000	0
80-81	2	TX_PWR(Slope)	0100	1
82-83	2	TX_PWR(Offset)	0000	0
84-85	2	T(Slope)	0100	1
86-87	2	T(Offset)	0000	0
88-89	2	V(Slope)	0100	1
90-91	2	V(Offset)	0000	0
92-94	3	Reserved	00	-
95	1	Checksum	-	

**ESD**

This transceiver is specified as ESD threshold 2kV for all electrical input pins, tested per MIL-STD-883, Method 3015.4 /JESD22-A114-A (HBM). However, normal ESD precautions are still required during the handling of this module. This transceiver is shipped in ESD protective packaging. It should be removed from the packaging and handled only in an ESD protected environment.

**LASER Safety**

This is a Class 1 Laser Product according to IEC 60825-1:1993:+A1:1997+A2:2001. This product complies with 21 CFR 1040.10 and 1040.11 except for deviations pursuant to Laser Notice No. 50, dated (July 26, 2001)



## Revision History

Date	Version	Description of Changes	Author
08/30/2017	Version 1.2	Correct 2-Wire Address A0H (40~55) "4F,42,4D,2D,41,33,43,42,32,2D,43,30,36,5F,56,33" on page 14.	Jack.Wang