

REV	ECN	APP'D
-	6299	JLS 5-29-09

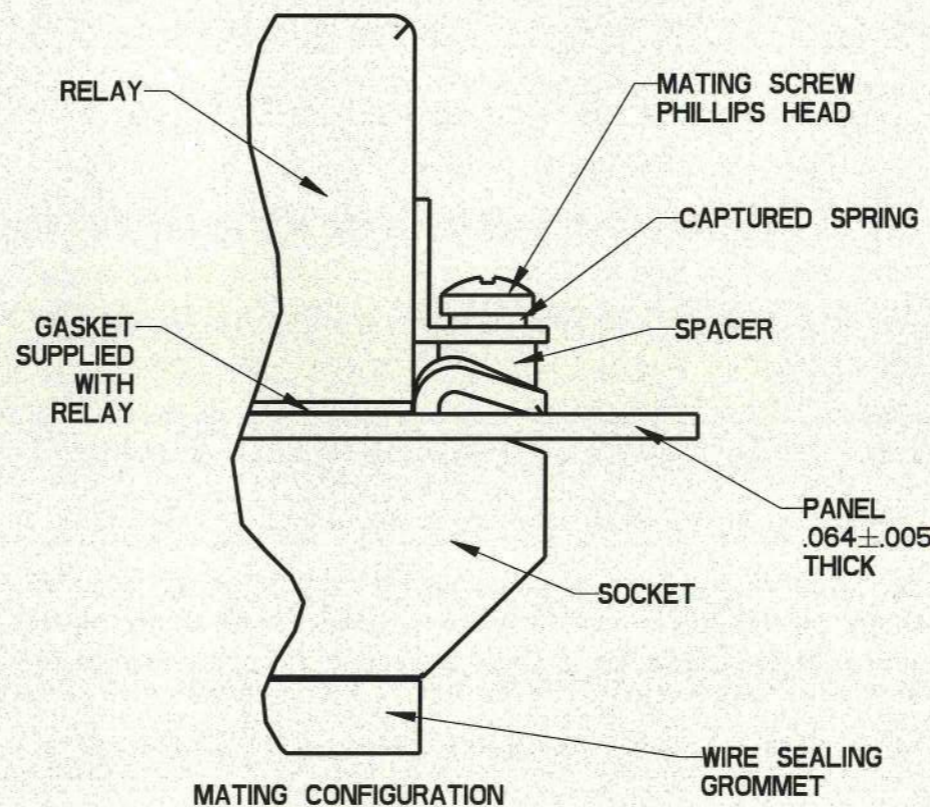
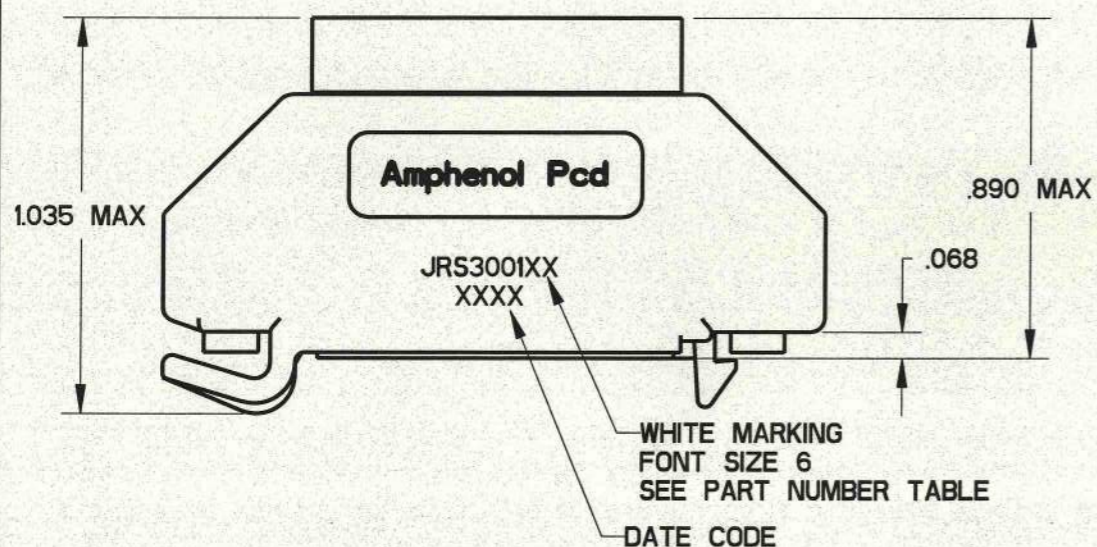
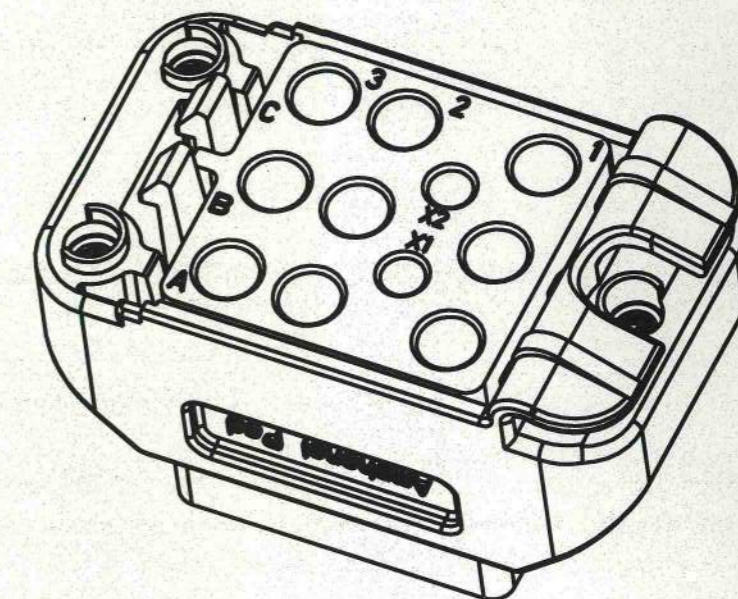
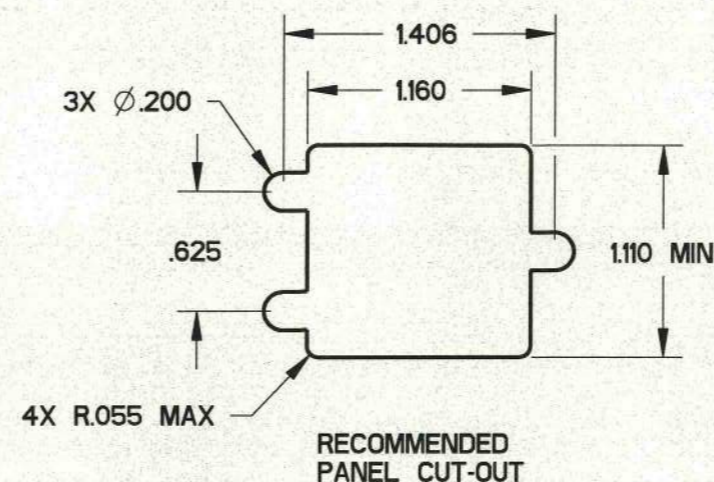
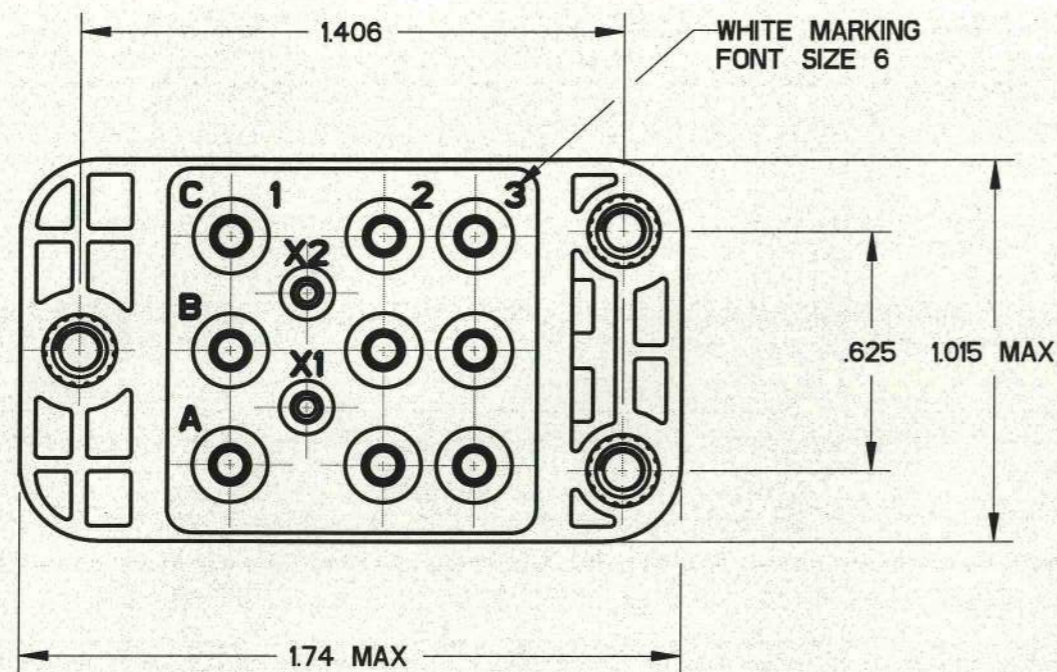

NOTES:

- MATERIALS:**
HOUSING: POLYETHERIMIDE PER ASTM-D5205
GROMMET: SILICONE RUBBER PER A-A-59588
THREADED INSERT: STAINLESS STEEL
- OPERATING RANGE:**
TEMPERATURE: -65 °C TO 125 °C
INSULATION RESISTANCE: 1000 MEGOHMS MIN.
DIELECTRIC WITHSTANDING VOLTAGE: 1500 VRMS AT SEA LEVEL AND 500 VRMS AT 80,000 FT. ALTITUDE
VIBRATION: MIL-STD-202, METHOD 204, TEST CONDITION G
SHOCK: MIL-STD-202, METHOD 213, TEST CONDITION C
- PART ACCEPTS M39029/92-533 AND M39029/92-535 SOCKET CONTACTS, SIZE 16/16 AND SIZE 12/12.

PART NUMBER TABLE

APCD P/N	HARDWARE PACKAGE	CONTACTS SUPPLIED
JRS300100	NONE	NONE
JRS300101	NONE	YES
JRS300110	YES	NONE
JRS300111	YES	YES

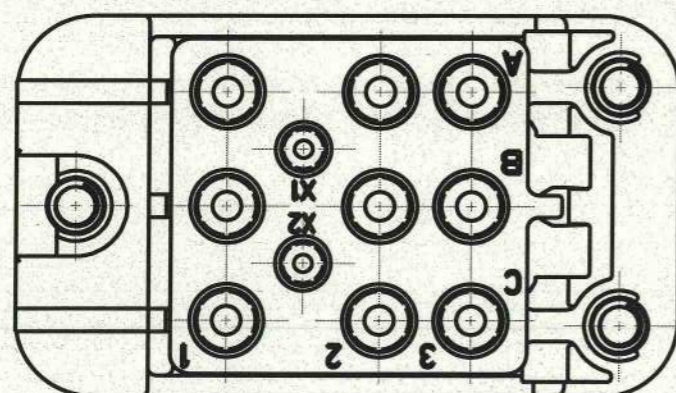

DIMENSIONS ANSI Y14.5M UNITS: INCHES Pro/E FILE	TOLERANCES .XX ±0.01 .XXX ±0.005 ANGLES ±1.0°	PROJECTION 	Amphenol Pcd SPECIFICATION DRAWING		TITLE SNAP-IN RELAY SOCKET 3 POLE	
			ENGR Frank.Li 07-Apr-08	CHKD <i>[Signature]</i> 5/25/09	APPD <i>[Signature]</i> 5-29-09	SIZE B
ORIGINAL 	THIS DOCUMENT CONTAINS PROPRIETARY INFORMATION WHICH IS THE CONFIDENTIAL PROPERTY OF AMPHENOL PCD INC., BEVERLY, MA			CODE: 58982	SCALE: 2:1	SHEET 1 OF 1

JRS300100

JRS300100