

THIS DRAWING IS UNPUBLISHED. RELEASED FOR PUBLICATION. COPYRIGHT BY TYCO ELECTRONICS CORPORATION. ALL RIGHTS RESERVED.

PART NUMBER	REV	FIRST USED
1385673-1	C	122500-1
1385673-2	C	565435-5
1385673-3	C	354500-1

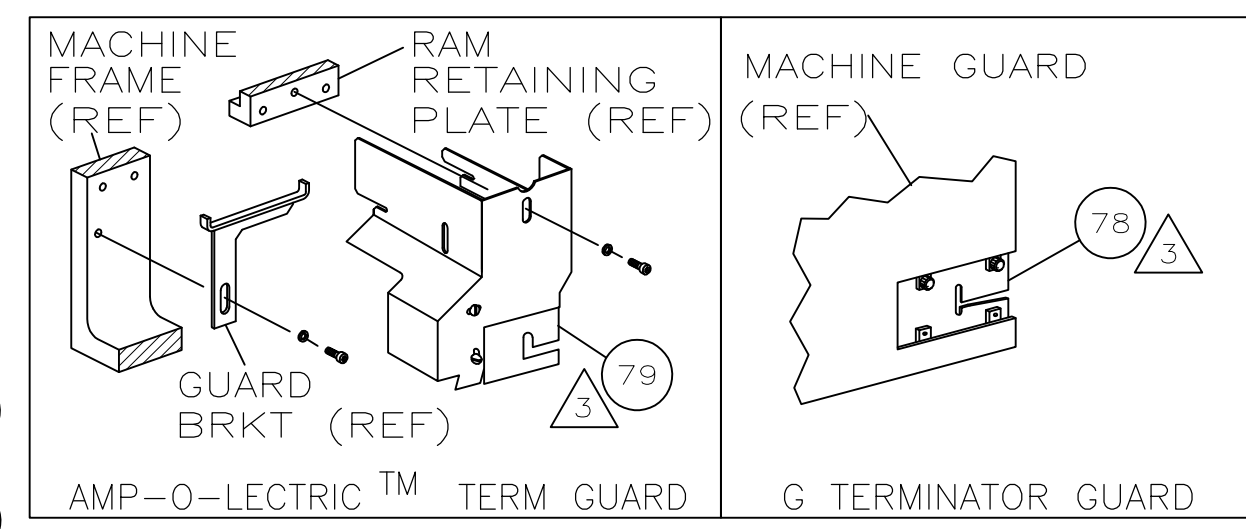

AMP TERM PN		MFR TERM PN		FORD TERMINAL		AMP CRIMP SPECS	
1572341	D9AZ-14474-A						
PAD LTR				CRIMP HEIGHT		WIRE SIZE	
A				.046 ±.002 [1.17 ±0.05mm]		18	
B				NOT		USED	
C				NOT		USED	
D				NOT		USED	
CRIMP				SIZE		TYPE	
WIRE				.090 [2.29mm]		F	
INSUL				.120 [3.05mm]		F	
WIRE STRIP LENGTH				TERM APPL SPEC		FEED	
.201-.218				NONE		.750	
				APPL INSTRUCTION		SET UP GAGE LAYOUT	
				408-8040		458637-1 L2895	

LOC	DIST	REVISIONS			
A	66	REV	DESCRIPTION	DATE	BY
		C	ECR-08-002924	1-2008	MY

-1	LEADMAKER	MECH POST FEED
-2	BENCH MODEL K	MECH PRE FEED
-3	BENCH MODEL G	MECH PRE FEED

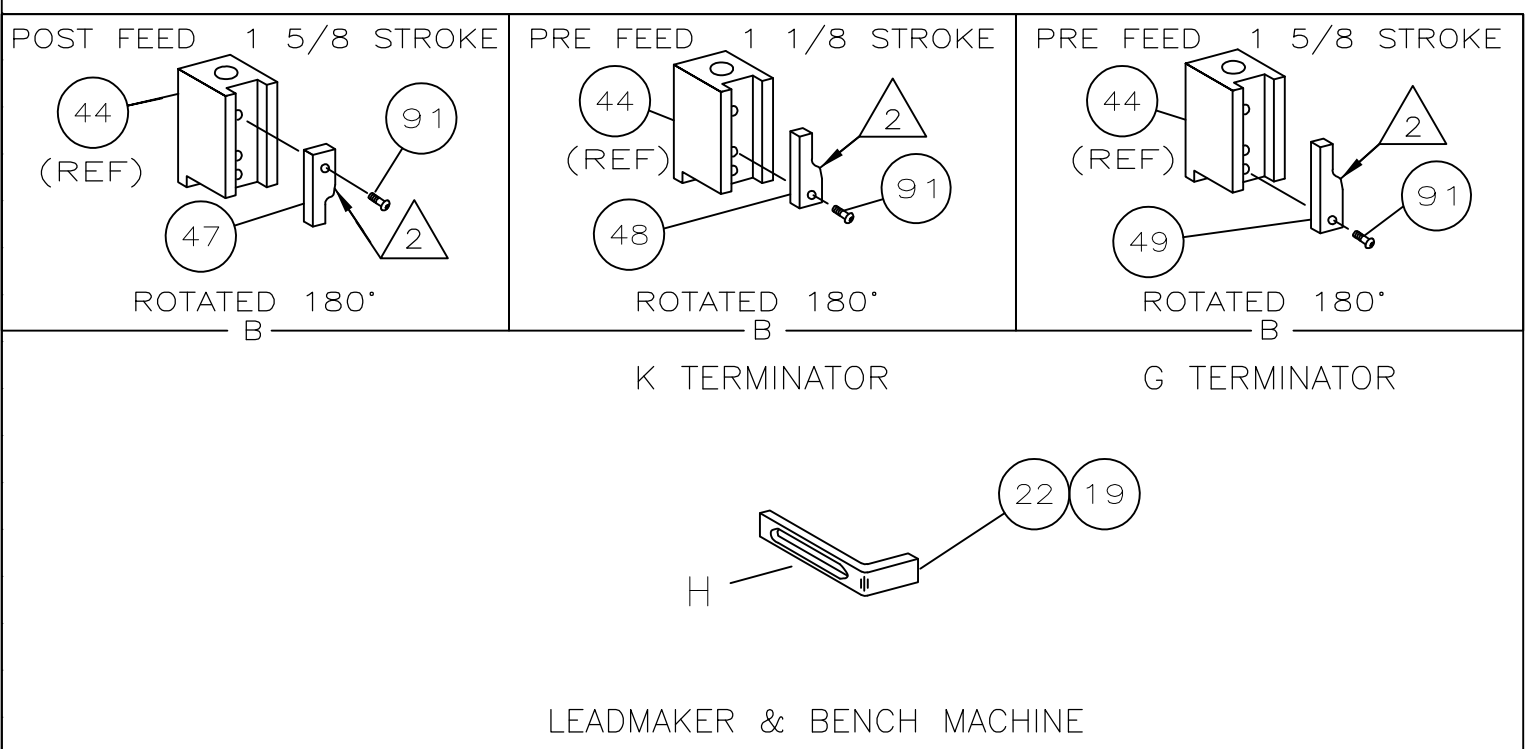
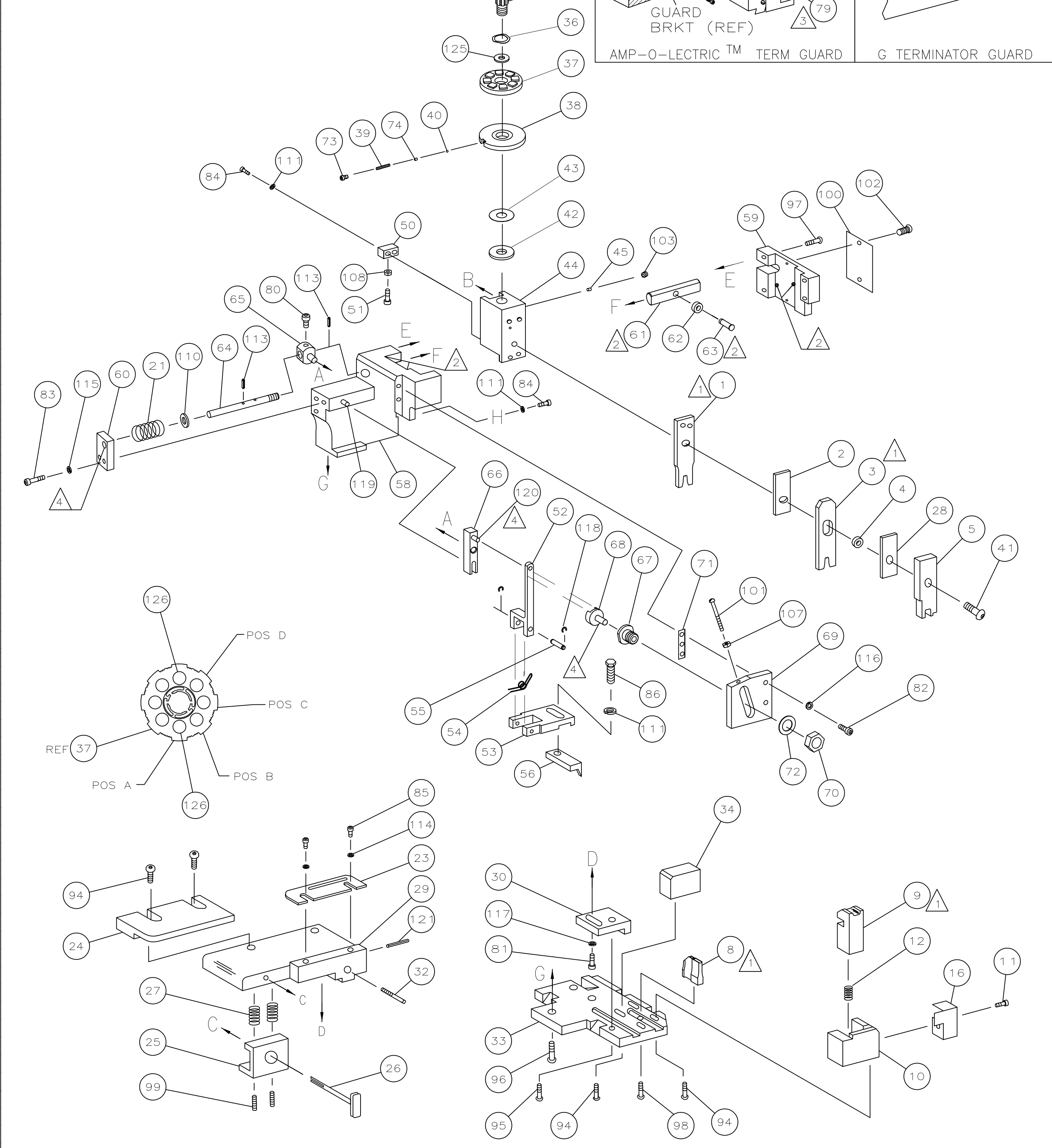

- 1 RECOMMENDED SPARE PARTS.
- 2 GREASE LIGHTLY.
- 3 GUARD MUST BE IN PLACE WHEN OPERATING APPLICATOR IN A BENCH MACHINE.
- 4 LUBRICATE DAILY USING NO. 20 MACHINE OIL.
5. ITEMS WITH QTY OF REF SPECIFIED (EXCEPT ITEMS 78 AND 79) ARE USED ON ITEM 46.

QTY	REF	REF	REF	DESCRIPTION	ITEM NO	
					129	
					128	
					127	
2	2	2	-	4-354779-3	PIN, WIRE DISC (.3205)A	126
1	1	1	-	986950-1	WASHER, FLAT PRECISION	125
1	1	1	-	217238-1	GENERAL INSTRUCTION PACKAGE	124
1	1	1	-	4088040	SF APPL INST 408-8040	123
					122	
1	1	1	-	4-21028-0	PIN,SLT SPR(Ø.093x.75)ST GDE PL	121
REF	REF	REF	-	1-21030-1	PIN,DOWEL(Ø.187x.50)LEVER	120
REF	REF	REF	-	1-21030-6	PIN,DOWEL(Ø.187x1.25)HOUSING	119
REF	REF	REF	-	21045-3	RING,RET "C"(Ø.187)FD FING PIN	118
1	1	1	-	21024-5	WASHER, LOCK(#10)ADJ BLOCK	117
REF	REF	REF	-	21024-5	WASHER,LOCK(#10)ADJ PLATE	116
REF	REF	REF	-	21024-5	WASHER,LOCK(#10)FEED GDE ROD	115
2	2	2	-	21024-2	WASHER,LOCK(#4)FRONT STP GUIDE	114
REF	REF	REF	-	5-21028-1	PIN,SLT SPR(Ø.125x.50)ADJ ROD	113
					112	
4	4	4	-	21024-4	WASHER,LOCK(#8)STRIPPER	111
REF	REF	REF	-	21899-4	WASHER,FLAT(Ø5/16)SCREW ADJ	110
					109	
1	1	1	-	21018-5	NUT,HEX(NO.6)HOLDDOWN	108
REF	REF	REF	-	21068-5	NUT,HEX(6-32)FEED ADJ	107
					106	
					105	
					104	
1	1	1	-	21009-2	SCR,SKT SET(1/4-20x.25 LW)RAM	103
2	2	2	-	21017-2	SCR,DRIVE(#2x.19)ID PLATE	102
REF	REF	REF	-	6-23715-5	SCR,PAN HD(6-32x1.50)FEED ADJ	101
1	1	1	-	461264-1	PLATE, IDENTIFICATION	100
2	2	2	-	5-21006-6	SCR,SET(10-32x.75)DRAG	99
1	1	1	-	22733-8	SCR,BHC(8-32x.38 LW)ANVIL	98
REF	REF	REF	-	2-21002-9	SCR,BHC(10-32x.75)CAP	97
REF	REF	REF	-	2-22733-8	SCR,BHC(1/4-20x.62)HOUSING	96
REF	REF	REF	-	2-21002-7	SCR,BHC(10-32x.50)SG ADJ BLOCK	95
6	6	6	-	2-21002-2	SCR,BHC(8-32x.50)TERM H DWN	94
					93	
					92	
1	1	1	-	1-21002-7	SCR,BHC(6-32x.38)CAM	91
					90	
					89	
					88	
					87	
1	1	1	-	2-22603-0	SCR,HEX HD(8-32x.31)FEED FINGER	86
2	2	2	-	1-21000-3	SCR,SHC(4-40x.25)FR ST GUIDE	85
3	3	3	-	2-21000-7	SCR,SHC(8-32x.50)STRIPPER	84
REF	REF	REF	-	3-21000-7	SCR,SHC(10-32x.75)FEED ROD GD	83
REF	REF	REF	-	3-21000-6	SCR,SHC(10-32x.62)FD ADJ BLK	82
1	1	1	-	3-21000-4	SCR,SHC(10-32x.38)SG ADJ BL	81
REF	REF	REF	-	3-21000-4	SCR,SHC(10-32x.38)PIVOT BLK	80
-	REF	-	-	455749-1	GUARD, WINDOW	79
REF	-	-	-	679532-1	INSERT, GUARD	78
					77	
					76	
					75	
1	1	1	-	690603-1	SPRING, ASSIST	74
1	1	1	-	23030-1	SCR,SHC(6-32x.25 SL)INS DISC	73
REF	REF	REF	-	458109-1	WASHER, SPECIAL	72
REF	REF	REF	-	690517-1	SPACER	71
-3	-2	-1	U/M	PART NO	DESCRIPTION	ITEM NO
PARTS LIST						
QTY REQD PER ASSY						

QTY	REF	REF	REF	DESCRIPTION	ITEM NO	
					70	
					69	
					68	
					67	
					66	
					65	
					64	
					63	
					62	
					61	
					60	
					59	
					58	
					57	
1	1	1	-	458537-2	PAWL, FEED	56
REF	REF	REF	-	240624-1	PIN, FEED FINGER	55
REF	REF	REF	-	691499-1	SPRING, FEED FINGER	54
REF	REF	REF	-	690541-1	HOLDER, FEED FINGER	53
REF	REF	REF	-	455679-1	LEVER, TERMINAL FEED ARM	52
1	1	1	-	811242-2	BUMPER, HOLDDOWN	51
1	1	1	-	690753-1	SPACER, TONKER	50
1	-	-	-	690602-6	CAM, PRE-FEED 1 5/8 ST	49
-	1	-	-	690602-5	CAM, PRE-FEED 1 1/8 ST	48
-	-	1	-	690501-4	CAM, POST-FEED 1 5/8 ST	47
1	1	1	-	459456-1	APPLICATOR, BASIC (SUBASSY)	46
1	1	1	-	690191-1	PLUG, NYLON	45
1	1	1	-	455673-1	RAM	44
1	1	1	-	690125-1	WASHER, LAMINATED	43
1	1	1	-	690124-1	WASHER, RAM	42
1	1	1	-	7-21002-9	BOLT, CRIMPER(5/16x1.00)	41
1	1	1	-	23241-6	BALL, STEEL	40
1	1	1	-	690170-1	SPRING, COMPRESSION	39
1	1	1	-	690142-1	DISC, INSULATION	38
1	1	1	-	354777-1	WIRE DISC, PLASTIC	37
1	1	1	-	22480-5	WASHER, SPRING	36
1	1	1	-	690212-1	POST, RAM	35
1	1	1	-	690786-6	SUPPORT, TERMINAL	34
REF	REF	REF	-	455675-1	PLATE, BASE	33
1	1	1	-	690432-3	SCREW, ADJUSTMENT	32
					31	
REF	REF	REF	-	455689-1	BLOCK, STRIP GUIDE ADJ	30
1	1	1	-	455671-1	PLATE, STRIP GUIDE	29
1	1	1	-	1-455888-0	SPACER, FRONT SHEAR DEP	28
2	2	2	-	1-22284-0	SPRING, DRAG	27
1	1	1	-	690546-1	LEVER, DRAG RELEASE	26
1	1	1	-	240792-1	DRAG, TERMINAL	25
1	1	1	-	9-690504-3	GUIDE, STRIP (REAR)	24
1	1	1	-	690438-1	GUIDE, STRIP (FRONT)	23
-	-	1	-	690472-2	STRIPPER	22
REF	REF	REF	-	4-22284-9	SPRING, FEED RETURN	21
					20	
1	1	-	-	691353-1	STRIPPER	19
					18	
					17	
1	1	1	-	318563-1	GUARD, CHIP, FRONT	16
					15	
					14	
					13	
1	1	1	-	3-22280-3	SPRING, SHEAR	12
1	1	1	-	690461-1	STOP, SHEAR	11
1	1	1	-	690459-1	HOLDER, SHEAR (FRONT)	10
1	1	1	-	454276-1	SHEAR, FLOAT (FRONT)	9
1	1	1	-	5-662187-4	ANVIL	8
					7	
					6	
1	1	1	-	1-455889-4	DEPRESSOR, SHEAR (FRONT)	5
1	1	1	-	238011-2	SPACER, BLOCK CRIMPER	4
1	1	1	-	4-1213077-4	CRIMPER, INSULATION	3
1	1	1	-	455888-4	SPACER, CRIMPER	2
1	1	1	-	1-456406-6	CRIMPER, WIRE	1
-3	-2	-1	U/M	PART NO	DESCRIPTION	ITEM NO
PARTS LIST						
QTY REQD PER ASSY						

THIS DRAWING IS A CONTROLLED DOCUMENT.

APPROVED: [Signature] DATE: 090303

DESIGNED: [Signature] DATE: 090303

NAME: SIDE FEED HDM APPLICATOR

SIZE: A1

SCALE: 1 OF 1

REV: C