

CR1216 MFR

3V Lithium Battery OEM

Technical Data Sheet

Specifications

Chemical System	Li / MnO ₂
Nominal Voltage	3 V
Nominal Capacity	30 mAh
Standard Discharge Current	0.1 mA
Max. Cont. Discharge Current *	1 mA
Average Weight	~ 0.7 g
Operating Temperature*	-30 - +70°C
Self Discharge at 23°C	< 1% / year

Dimensions

(According to IEC 60086)

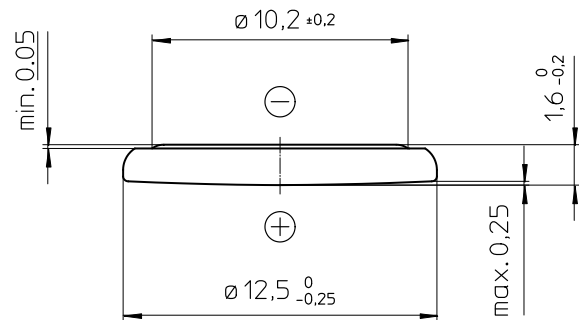

Performance

Discharge performance at 23°C

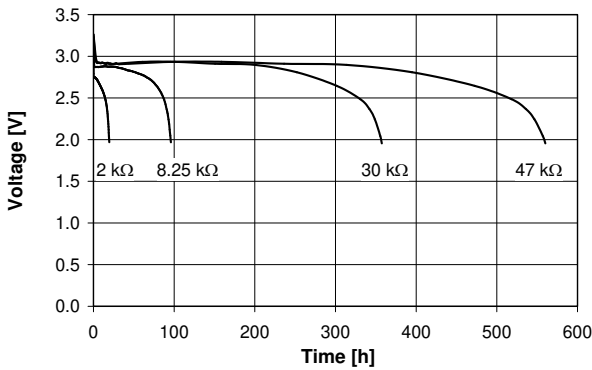

Discharge performance at 23°C

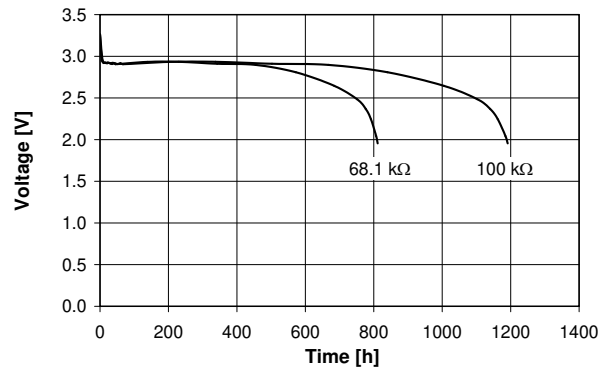

Temperature performance Load 47kΩ

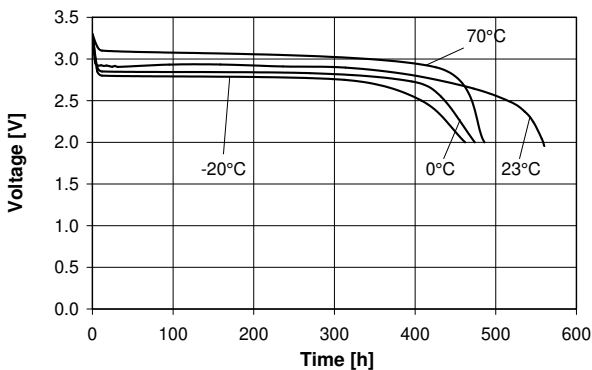

Cell capacity at various loads

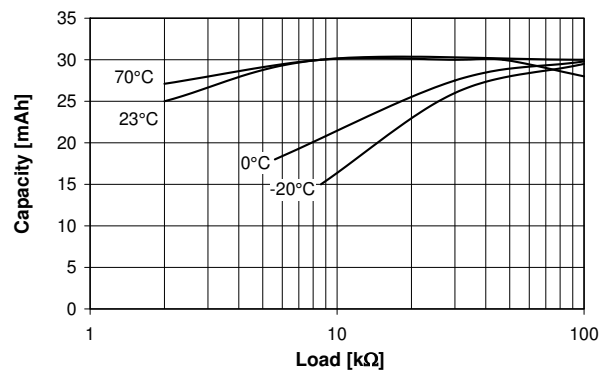

*In applications where the battery is exposed to temperatures above 60 °C, please contact Renata for consultancy.

*Average discharge current for a yield of 70% of the nominal capacity with cut-off voltage of 2.0V at 23°C.

Information and contents in this data sheet are for reference purpose only. They do not constitute any warranty or representation and are subject to change without notice. For most current information and further details, please contact your Renata representative.