



**ANALOG  
DEVICES**

# SPI<sup>®</sup>-/I<sup>2</sup>C<sup>®</sup>-Compatible, Temperature Sensor, 4-Channel ADC and Quad Voltage Output DAC

## EVAL-ADT7516

### FEATURES

**Easy evaluation of the ADT7516**  
**Can be used to emulate ADT7517 and ADT7519**  
**Evaluation software included**  
**USB interface to PC**  
**Powered from USB interface**

### APPLICATIONS

**Portable battery-powered instruments**  
**PCs**  
**Smart battery chargers**  
**Telecommunications systems**  
**Electronic test equipment**  
**Domestic appliances**  
**Process controls**

### INTRODUCTION

The ADT7516 evaluation board allows the ADT7516 digital temperature sensor, 4-channel ADC and quad DAC to be quickly and easily evaluated using a PC. Using the evaluation board and its accompanying software, the ADT7516 evaluation board can be interfaced to any PC running Windows<sup>®</sup> XP, Windows 2000 or higher, via one of the computer's USB ports.

The two other parts in the family, the [ADT7517](#) and [ADT7519](#), differ only in that they have 10-bit and 8-bit DACs, respectively. The ADT7516 evaluation board can be used to emulate the ADT7517 by setting the two LSBs of the DACs to zero and for the ADT7519 by setting the four LSBs of the DACs to zero.

The evaluation board allows all the input and output functions of the ADT7516 to be exercised without the need for external components. The software allows control and monitoring of the ADT7516's internal registers.

### EVALUATION SYSTEM PACKAGE CONTENTS

The evaluation system package contains the following items:

- The ADT7516 evaluation board data sheet on CD
- The ADT7516 evaluation board
- Evaluation software on CD
- USB A to Mini-B cable

#### Rev. A

Evaluation boards are only intended for device evaluation and not for production purposes. Evaluation boards as supplied "as is" and without warranties of any kind, express, implied, or statutory including, but not limited to, any implied warranty of merchantability or fitness for a particular purpose. No license is granted by implication or otherwise under any patents or other intellectual property by application or use of evaluation boards. Information furnished by Analog Devices is believed to be accurate and reliable. However, no responsibility is assumed by Analog Devices for its use, nor for any infringements of patents or other rights of third parties that may result from its use. Analog Devices reserves the right to change devices or specifications at any time without notice. Trademarks and registered trademarks are the property of their respective owners. Evaluation boards are not authorized to be used in life support devices or systems.

One Technology Way, P.O. Box 9106, Norwood, MA 02062-9106, U.S.A.  
Tel: 781.329.4700 [www.analog.com](http://www.analog.com)  
Fax: 781.461.3113 ©2007 Analog Devices, Inc. All rights reserved.

## TABLE OF CONTENTS

Features .....	1	AIN Analog Input Connector, P2 .....	3
Applications .....	1	Test Points .....	3
Introduction .....	1	Evaluation Board Software .....	4
Evaluation System Package Contents .....	1	Installing the Software .....	4
Revision History .....	2	Using the Software .....	5
Evaluation Board Hardware .....	3	Evaluation Board Schematics and Artwork .....	9
Using the Hardware .....	3	Ordering Information .....	14
Mini-B USB Connector, J1 .....	3	Bill of Materials .....	14
DAC Output Connector, J2 .....	3	Ordering Guide .....	15
VREF Input Connector, P1 .....	3	ESD Caution .....	15

## REVISION HISTORY

2/07—Revision A: Initial Version

## EVALUATION BOARD HARDWARE

The ADT7516/ADT7517/ADT7519 combine a 10-bit temperature-to-digital converter and a quad 12-/10-/8-bit DAC, respectively, in a 16-lead QSOP. This includes a band gap temperature sensor and a 10-bit ADC to monitor and digitize the temperature reading to a resolution of 0.25°C. The ADT7516/ADT7517/ADT7519 operate from a single 2.7 V to 5.5 V supply. The input voltage range on the ADC channels is 0 V to 2.28 V, and the input bandwidth is dc. The reference for the ADC channels is derived internally. The output voltage of the DAC ranges from 0 V to  $V_{DD}$ , with an output voltage settling time of typically 7 ms.

The ADT7516/ADT7517/ADT7519 provide two serial interface options, a 4-wire serial interface that is compatible with SPI, QSPI™, MICROWIRE™, and DSP interface standards and a 2-wire SMBus/I<sup>2</sup>C interface. These products feature a standby mode that is controlled via the serial interface.

The ADT7516 evaluation board contains the following main components, which can be identified from the printed circuit board (PCB) silkscreen and the schematic diagram (see Figure 15 to Figure 19):

- ADT7516 IC, U9
- USB microcontroller, U1
- Interface buffers and analog switches
- Power LED, D1
- Interrupt LED, D2
- Temperature Sensor, Q1
- Photo diode sensor, U14
- Bargraph driver and LED bargraph, U12/U8
- Connector for USB interface, J1
- DAC output connector, J2
- VREF input connector, P1
- AIN analog input connector, P2
- LDAC push-button, S1

## USING THE HARDWARE

The hardware is extremely simple to use. Before connecting the evaluation board to a USB port on the PC, using the USB A to Mini-B cable provided, make sure the software is installed. No external power supply is required.

### MINI-B USB CONNECTOR, J1

The connections to J1 are shown in Table 1.

**Table 1. J1 Connections**

J1 Pin	Mini-B Function
1	5 V
2	–Data
3	+Data
4	Key (Not Used—Connected to Ground)
5	Ground

The communication between the Mini-B plug and the rest of the evaluation board is handled by the USB microcontroller, U1.

### DAC OUTPUT CONNECTOR, J2

The output of any one of the four DACs (selected by the software) is available on this connector.

### VREF INPUT CONNECTOR, P1

The architecture of one DAC channel consists of a resistor string DAC followed by an output buffer amplifier. The reference voltage for the selected DAC is determined by the on-chip reference of 2.28 V or an external reference voltage, which may be connected to P1.

### AIN ANALOG INPUT CONNECTOR, P2

The ADT7516/ADT7517/ADT7519 offers four single-ended analog input channels, which range from 0 V to 2.28 V, or 0 V to  $V_{DD}$ . This analog input may be connected using P1.

### TEST POINTS

Various system logic signals and the individual DAC outputs are available at the test points on the board.

## EVALUATION BOARD SOFTWARE

The software allows the ADT7516's functions to be controlled from a PC via an easy-to-use interface operating under Windows XP, Windows 2000, or higher. The contents of the device's internal registers can be easily read or altered through a user friendly interface, while the **Visual Display** dialog box gives a graphical display of temperature and voltage and allows the overtemperature limit to be altered using a slider control.

### INSTALLING THE SOFTWARE

To install the software, insert the CD. Click **Start > Run**, and enter **X:ADT7516Eval.exe**, where X is the letter of your CD drive, and then click **OK**.

Alternatively, run **Windows Explorer** or **My Computer**, select the CD drive, and double-click the **ADT7516 v2.0.2.exe** icon.

The installer extracts the files needed to install the software and starts the **InstallShield® Wizard**.

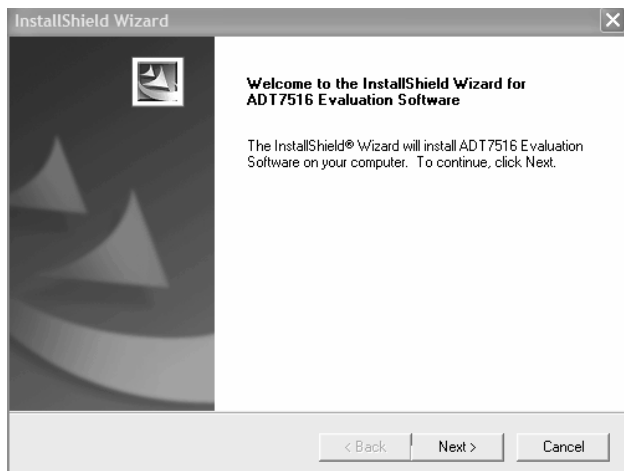

Figure 1. InstallShield Wizard Startup Screen

Click **Next >** to continue the installation. Various installation options are available, depending on whether a version of the software is already installed. A license agreement appears if this is a completely new installation. Click **Yes** to accept the agreement and continue with the installation.

If you want to install the software in the default folder shown, click **Next >**. Otherwise, click **Browse** and choose a different folder. Select the folder in which to install the program and click **OK**.

You are given the option of a **Typical**, **Compact**, or **Custom** installation of the software. Select the desired option, then click **Next >**.

If **Custom** is selected, a window appears allowing individual components to be installed. Uncheck any components you do not wish to install, and click **Next >**.

If a **Typical** or **Compact** installation is selected, omit this step, and the **Select Program Folder** dialog box will appear immediately. This allows you to select the program folder to add program icons. Select the desired folder and click **Next >**.

**InstallShield** now installs the program files to the selected folders.

Click **Finish** to complete the installation.

If an existing version of the software is found during installation, you may modify the existing installation by adding or removing components, repair the installation by replacing existing files with ones from the CD (useful if a file has been corrupted), or uninstall the entire software package.

Select the desired option and click **Next >**. If **Modify** is selected, you may add or remove components. If **Repair** is selected, all of the installed files are replaced with new files from the CD.

If **Remove** is selected, a prompt appears to confirm the complete removal of the software. Click **OK** to confirm removal of the software. During removal of the software, you may need to confirm removal of some files.

These files may be used by other Analog Devices, Inc.'s software. If no other Analog Devices software is installed on the system, it is safe to delete the files. To remove all shared files without further prompting, check **Don't display this message again** before clicking **Yes**.

Click **Finish** to complete the maintenance procedure.

## USING THE SOFTWARE

When using the software, first ensure that the evaluation board is connected to the USB port and the Power LED D1 is on.

To start the software, click **Start > All Programs > Analog Devices > ADT7516 Evaluation Software > ADT7516 Evaluation Software**.

The software searches for the evaluation board and initializes it.



Figure 2. ADT7516 Found

If the evaluation board is not found, the message in Figure 3 appears. If this happens, check that the evaluation board is correctly connected, that D1 is lit, and then try again.

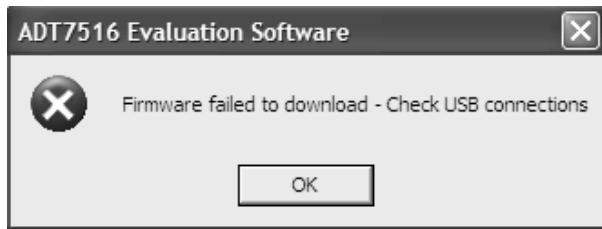

Figure 3. ADT7516 Not Found

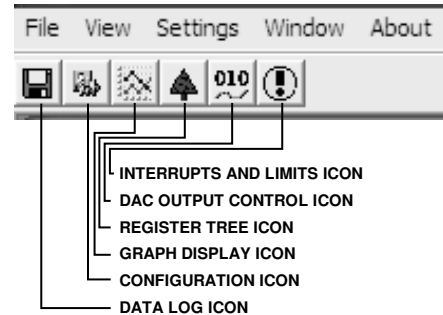

Figure 4. Menu and Icon Bar

At the top of the program window is a series of drop-down menus and menu icons that can be used to access the various functions of the software (see Figure 4 and the following list) or use the **Settings** menu to select these functions.

**Register Tree Icon:** Displays a tree of the device registers.

**Configuration Icon:** Allows the device to be configured.

**Graph Display Icon:** Displays graphs of temperature and voltage. The **View** menu can also be used to select these functions.

**DAC Output Control Icon:** Allows the DAC outputs to be adjusted. The **Settings** menu can also be used to select these functions.

**Interrupts and Limits Icon:** Sets up interrupts and limits.

**Data Log Icon:** Allows data to be logged and saved. The **File** menu can also be used.

Multiple windows for the previous software functions can be open and active simultaneously. The **Window** menu shows which window is on top and allows any window to be brought to the front.

### Configuration

Click the **Configuration** icon or use the **Device** menu to access the **Configuration** dialog box, which allows the **ADT7517** to be set up. It consists of a set of four tabs that allow various functions of the device to be configured.

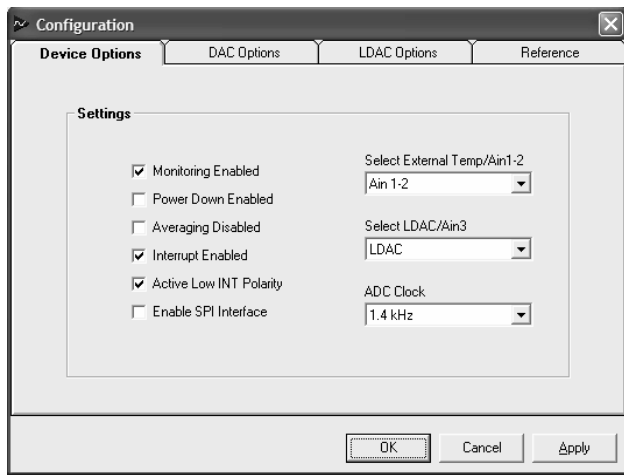

Figure 5. Device Options

The **Devices Options** tab (see Figure 5) selects or enables/disables various options:

- Monitoring
- Power Down
- Averaging
- Interrupt
- Active Low INT Polarity
- SPI Interface

Note that if the **ADT7516** SPI interface is enabled, to switch back to I<sup>2</sup>C interface, it is necessary to exit the software, disconnect the board, and start again.

The Pin AIN1 to Pin AIN3 are multiplexed and their operation can also be toggled here.

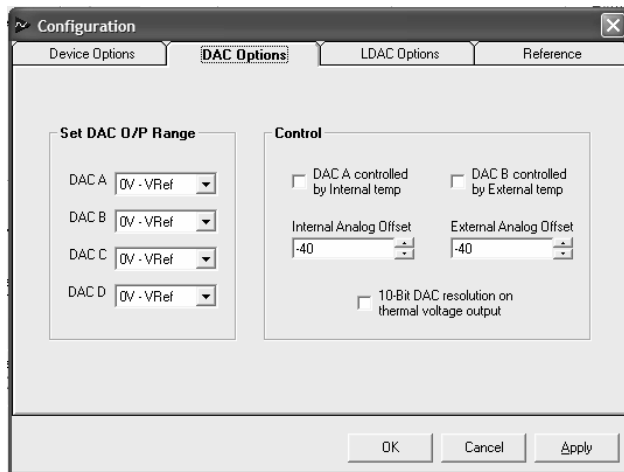

Figure 6. DAC Options

The **DAC Options** tab (see Figure 6) selects the output range for each DAC (0 to VRef or 0 to 2 VRef). It allows the thermal voltage function of the device to be configured, where the ADT7516 operates as a temperature-to-voltage converter, with DAC A controlled by the on-chip temperature sensor,

and DAC B controlled by the external temperature sensor. The temperature corresponding to 0 V output can be set by adjusting the analog offset for each channel, and the resolution for the thermal voltage function can be set to 8 bits or 10 bits.

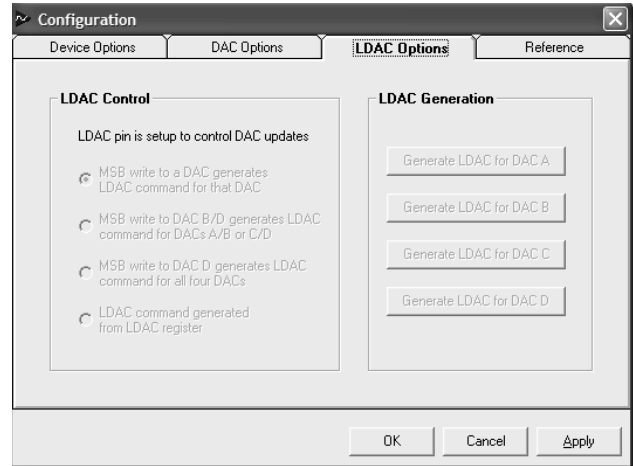

Figure 7. LDAC Options

The **LDAC Options** tab (see Figure 7) selects how the DACs are updated. They can be updated manually from the LDAC pin by pressing S1, when the MSBs are written to one of the DACs (three different options are available), or from the LDAC register. If the LDAC register is selected, the buttons on the right of the dialog box are active and clicking on one of them updates the corresponding DAC.

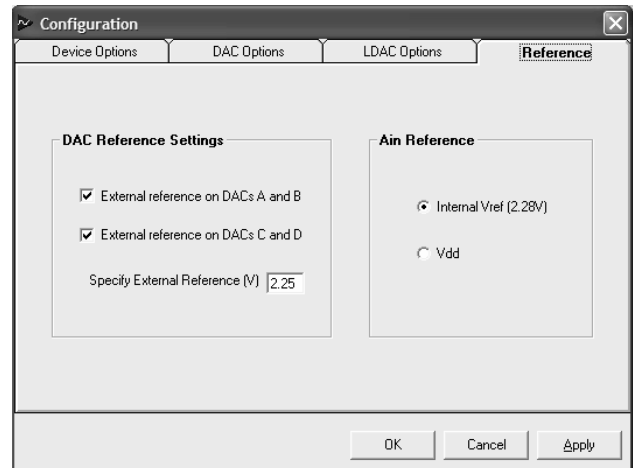

Figure 8. Reference Options

The **Reference** tab (see Figure 8) selects the internal 2.28 V reference for DACs A and B and DACs C and D, or an external reference connected to P1. If an external reference voltage is used, its value should be specified in the box provided. This allows the DAC value to be scaled correctly.

### Register Access

Click the **Register Tree** icon or use the **View** menu to select the **Register Map Access** window.

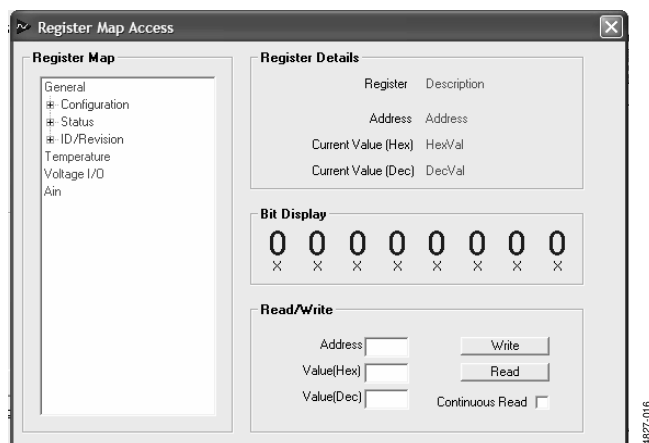

Figure 9. Register Map Access Window

The **Register Map Access** dialog box (see Figure 9) allows the contents of individual registers to be viewed, and those registers that are read/write can have their contents changed. The window on the left shows the registers arranged by function as a tree. The branches can be expanded or contracted by double clicking the desired labels or the + or – symbols.

The name of the register, its address, and its contents in hexadecimal, decimal, and binary are displayed. The register contents can be read by clicking **Read**, or set to continuous reading by checking the **Continuous Read** box. Those registers that are read/write can have their contents changed by clicking on individual bits of the binary display to toggle them, or by entering a decimal or hexadecimal value in the **Read** and **Write** section and clicking **Write**.

### Graphing

Click the **Graph Display** icon or use the **View** menu to access the **Graphing** window (see Figure 10).

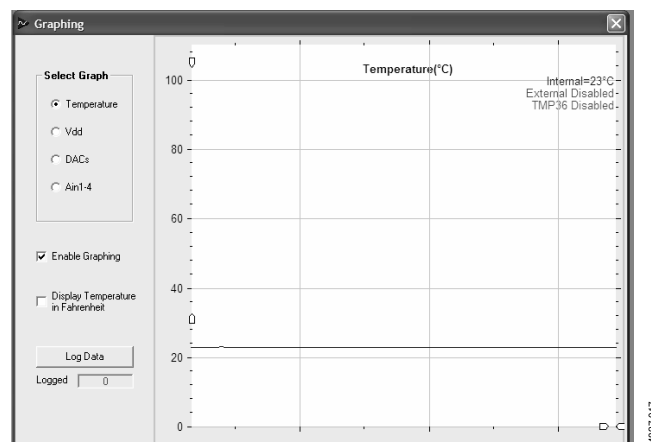

Figure 10. Graphing Window

The **Graphing** dialog box (see Figure 10) allows the internal or external temperature,  $V_{DD}$ , the DAC outputs, or Pin AIN1 to Pin AIN4 to be displayed as a rolling graph. Measurement limits can also be displayed. To view the graphic data in more or less detail, move the arrow pointers on the X- and Y-axes to zoom in or zoom out.

### DAC Control

Click the **DAC Output Control** icon or use the **Device** menu to access the **DAC Control** window (see Figure 11).

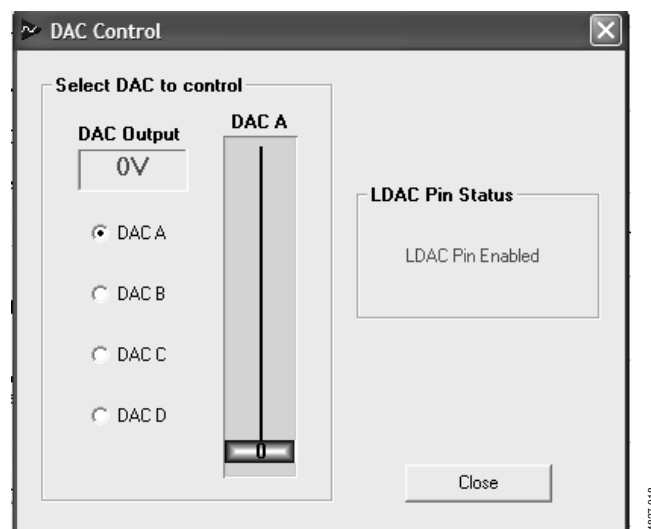

Figure 11. DAC Control Dialog Box

The **DAC Control** dialog box allows the individual DACs to be controlled manually without having to manipulate the DAC registers directly. A DAC can be selected and controlled using the check boxes and the slider.

## Setting Interrupts and Limits

Click the **Interrupts and Limits** icon or use the **Device** menu to access the **Interrupt Settings** dialog box (see Figure 12).

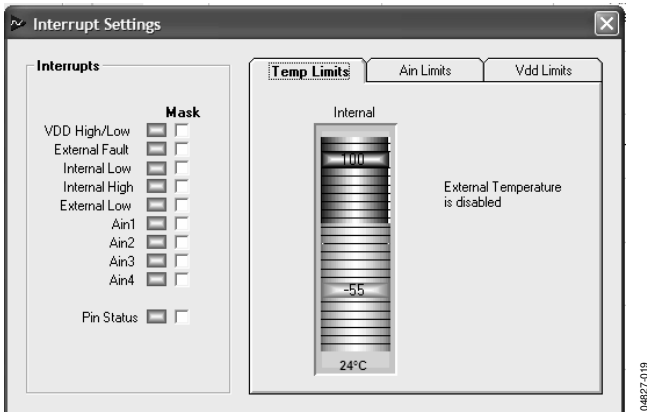

Figure 12. Interrupt Settings Dialog Box

The nine interrupt sources are shown on the left-hand side of the window. When an interrupt is asserted, corresponding green status indicator turns red. Interrupts can be masked by checking the box next to the name of the interrupt source. High and low limits for the measured parameters can be set using the slider controls.

## Data Logging

Click the **Data Log** icon or use the **File** menu to access the **Logging/Save/Recall** dialog box.

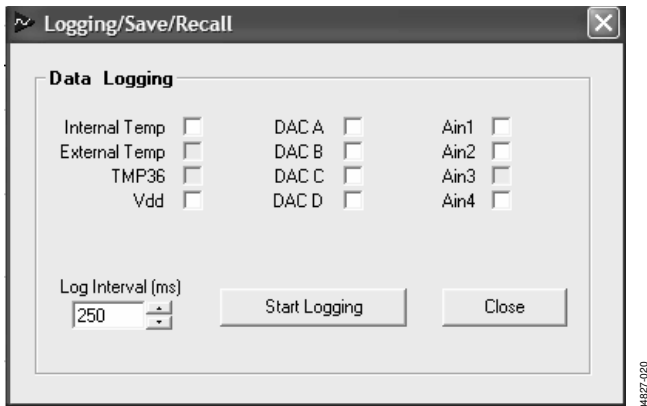

Figure 13. Data/Save/Recall Dialog Box

The **Logging/Save/Recall** dialog box (see Figure 13) allows you to set which inputs are logged and the log interval. Once this is set up, the window in Figure 14 appears.

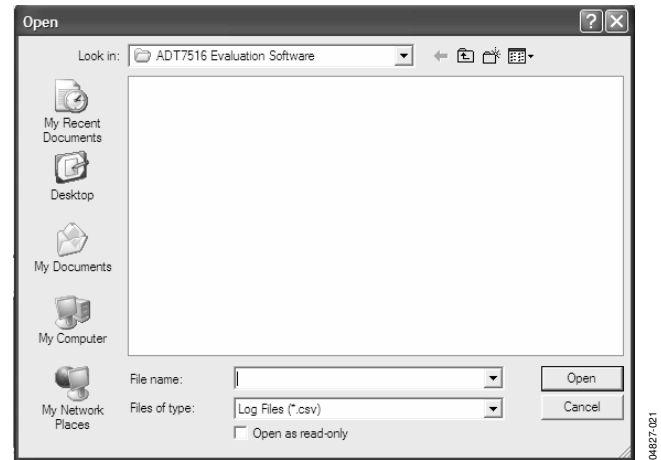

Figure 14. Opening or Creating a Log File

You can use the **Open** window (see Figure 14) to open an existing log file or create a new log file by typing in a new file name. After selecting an existing file or typing a new file name, click **Open** to begin data logging, and then click **Start Logging**. To stop data logging, click **Stop Logging**. Note that the **Graphing** function must be running during data logging or the data does not change.



EVALUATION BOARD SCHEMATICS AND ARTWORK

04827-001

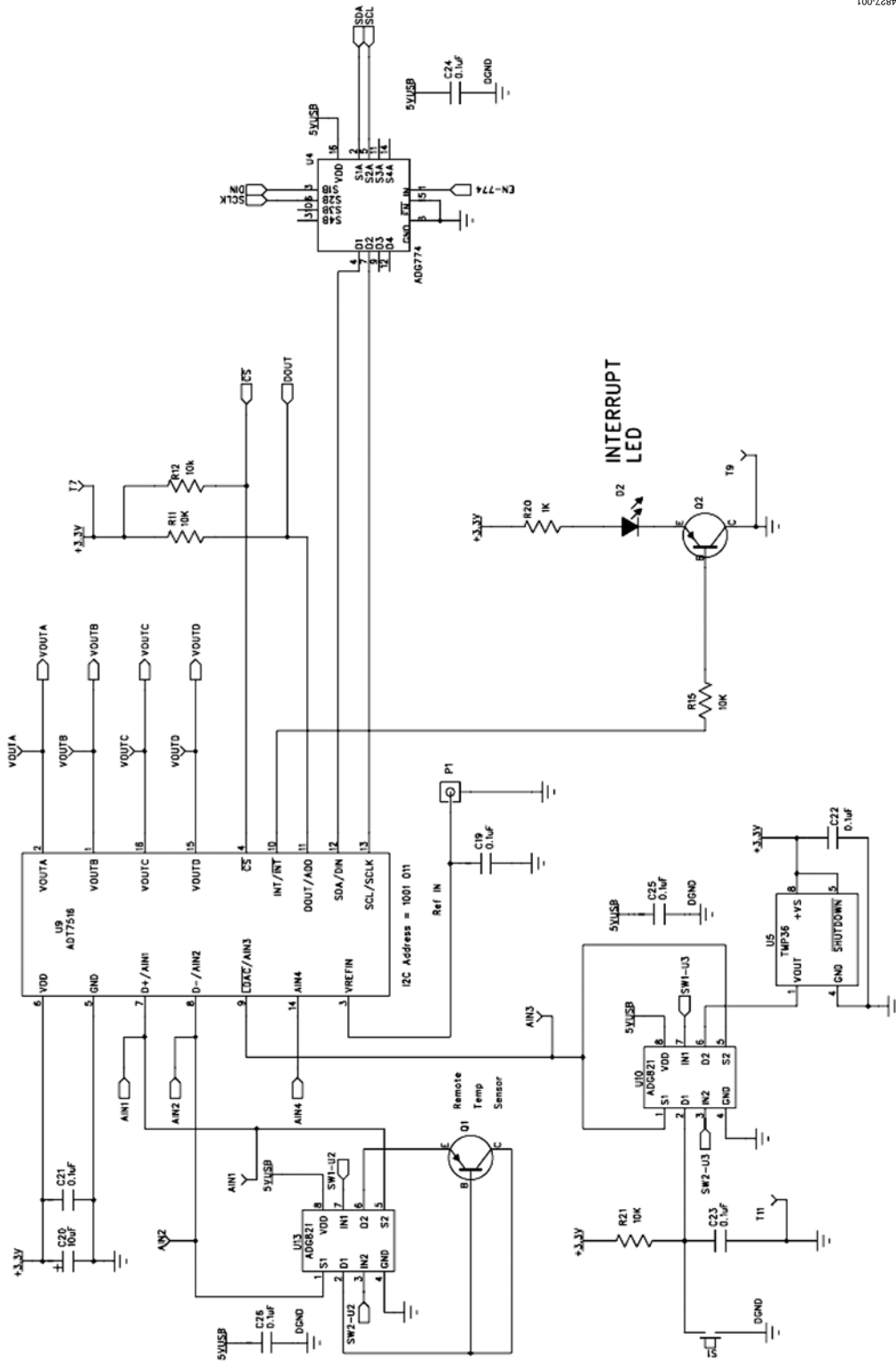

Figure 15. ADT7516 Evaluation Board Schematic Part 1

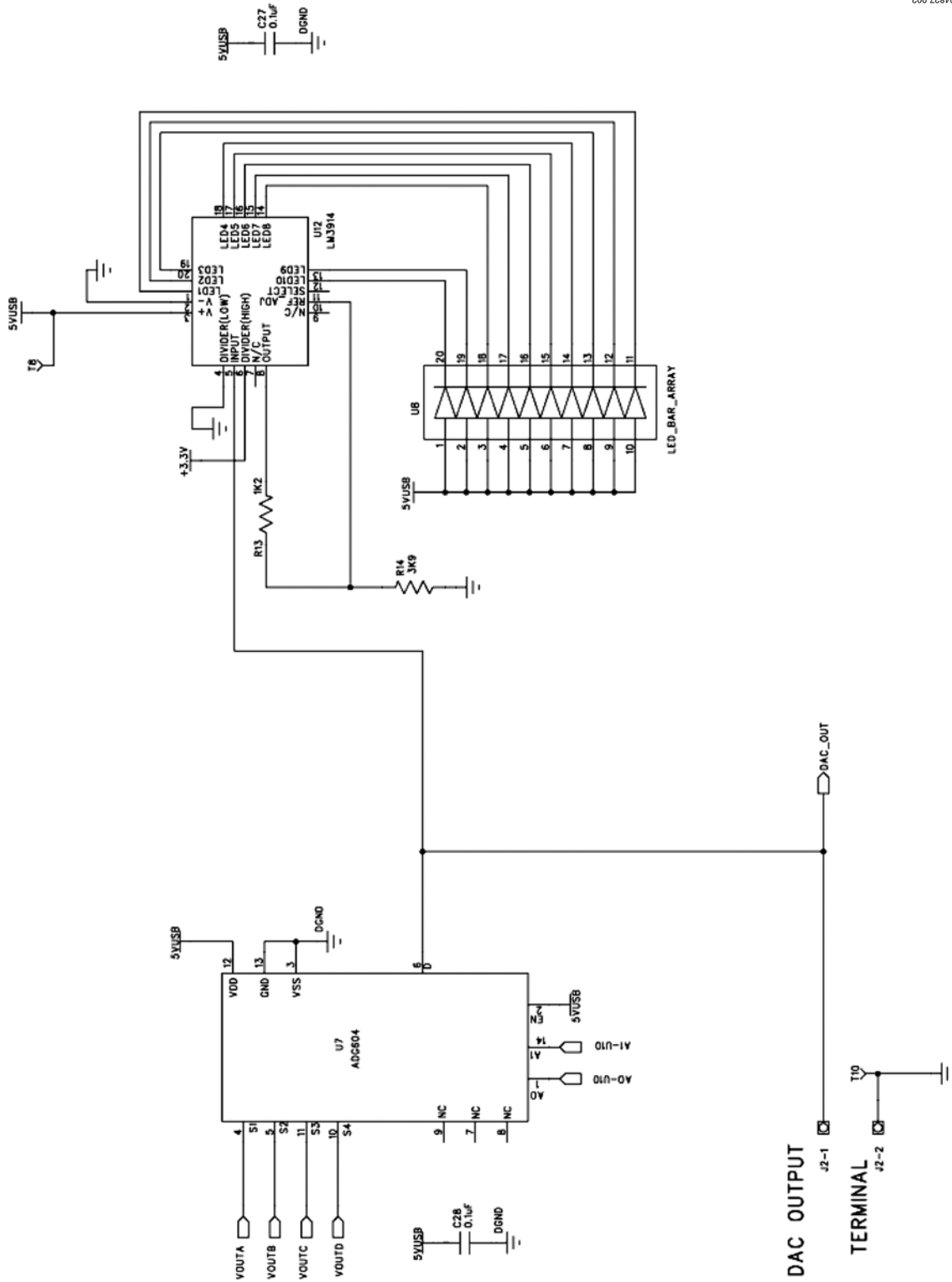

Figure 16. ADT7516 Evaluation Board Schematic Part 2

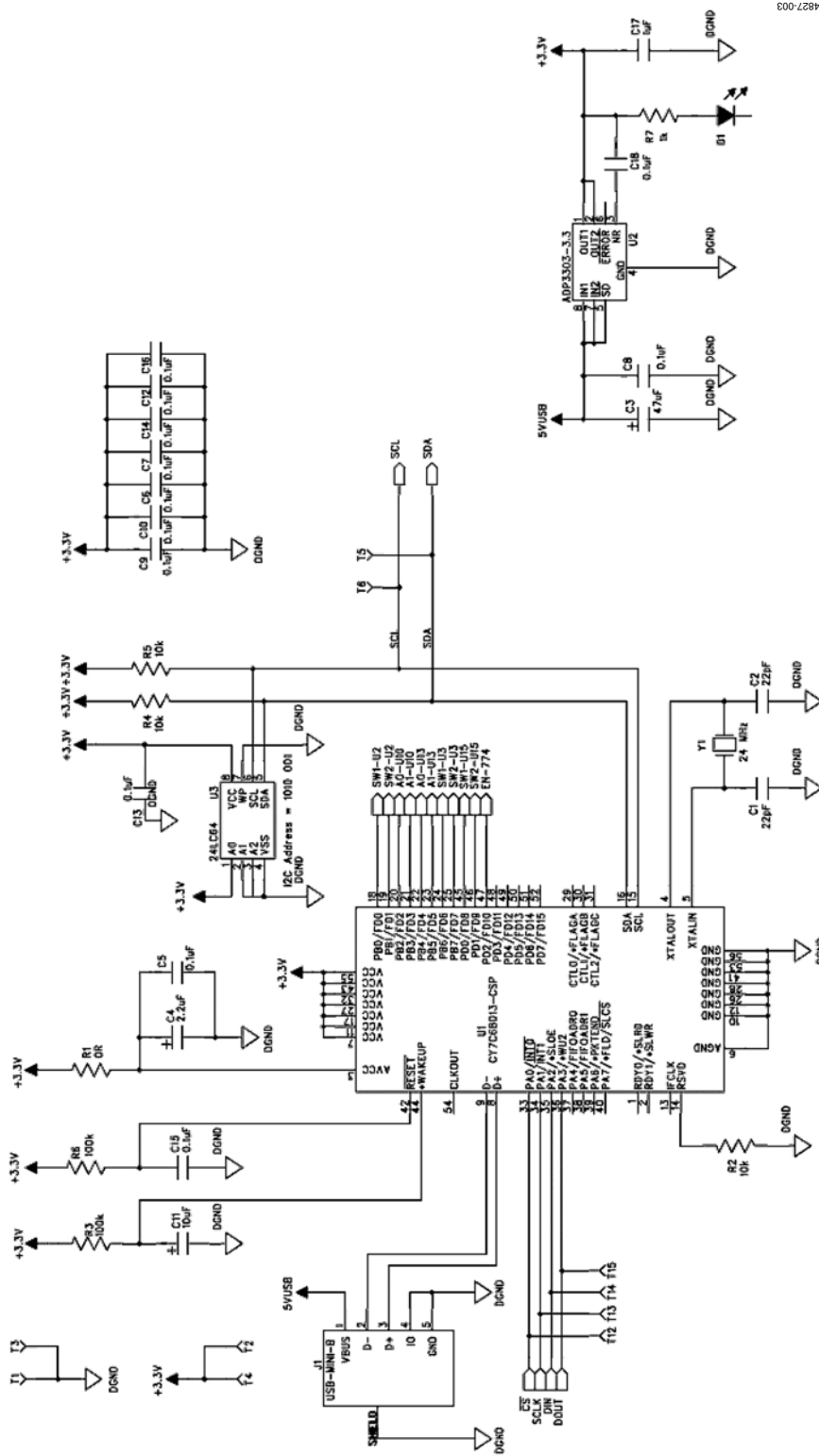

Figure 17. ADT7516 Evaluation Board Schematic Part 3

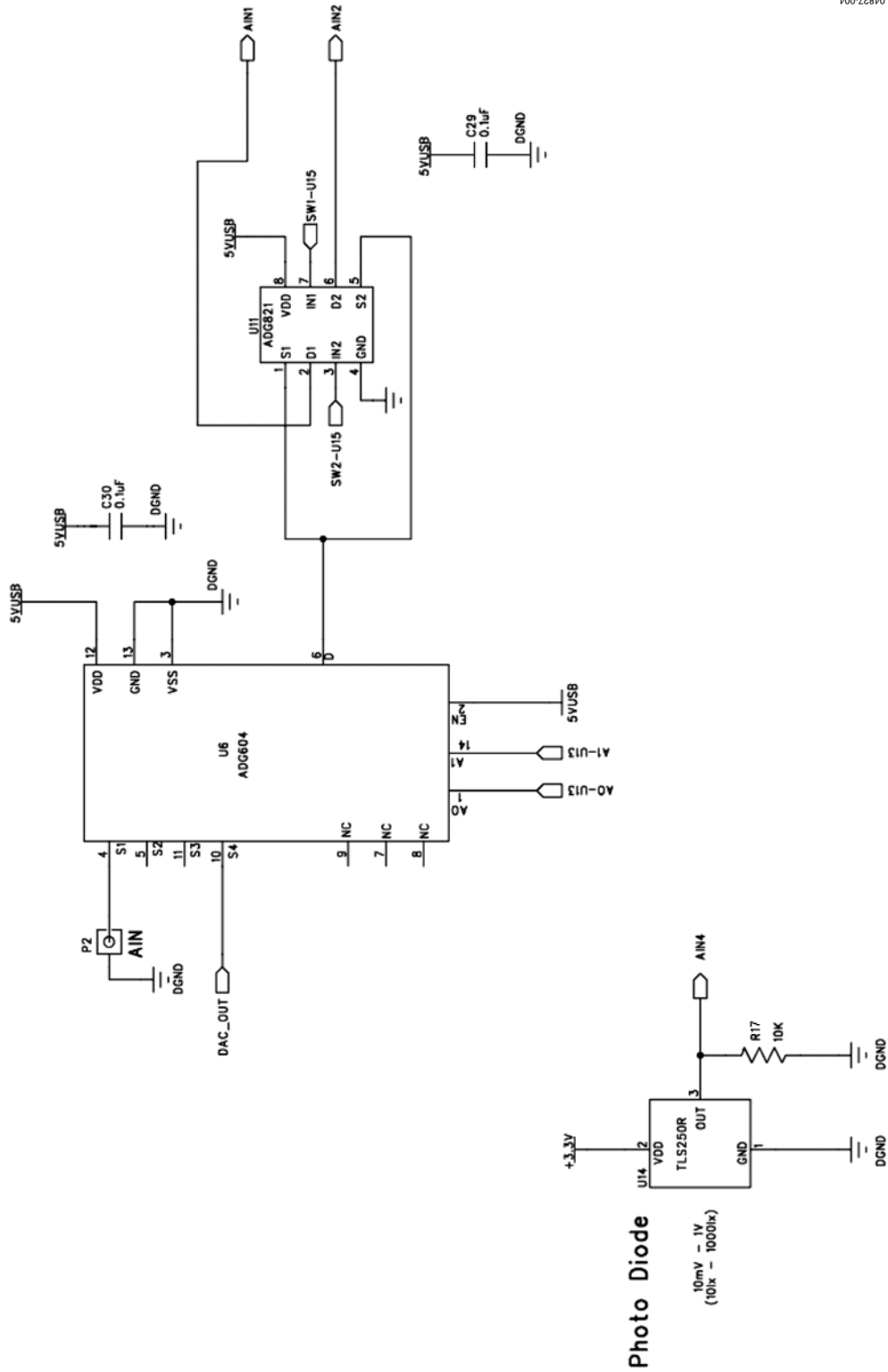

Figure 18. ADT7516 Evaluation Board Schematic Part 4

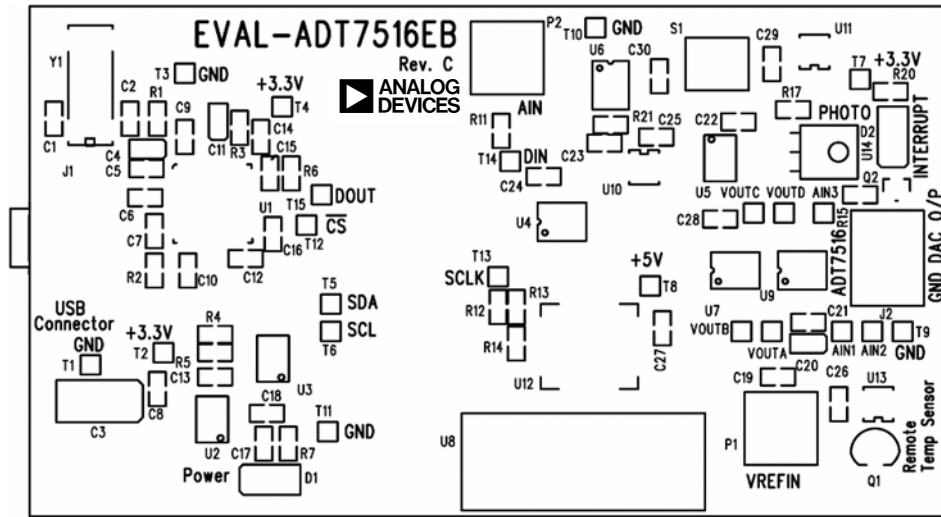

Figure 19. ADT7516 Evaluation Board Silkscreen

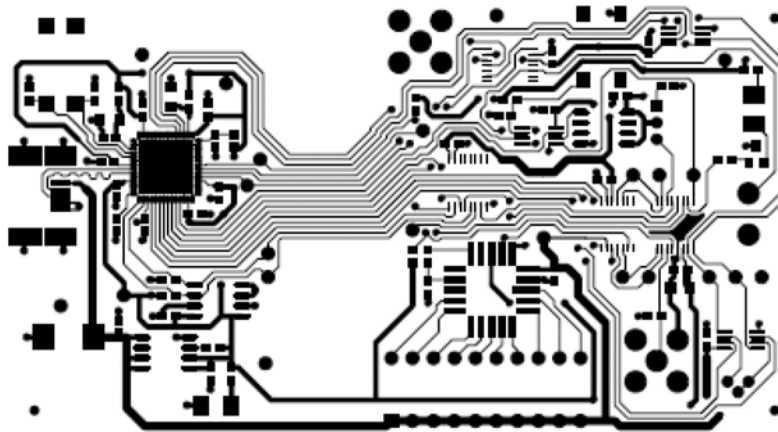

Figure 20. ADT7516 Evaluation Board PCB Layout (Component Side)

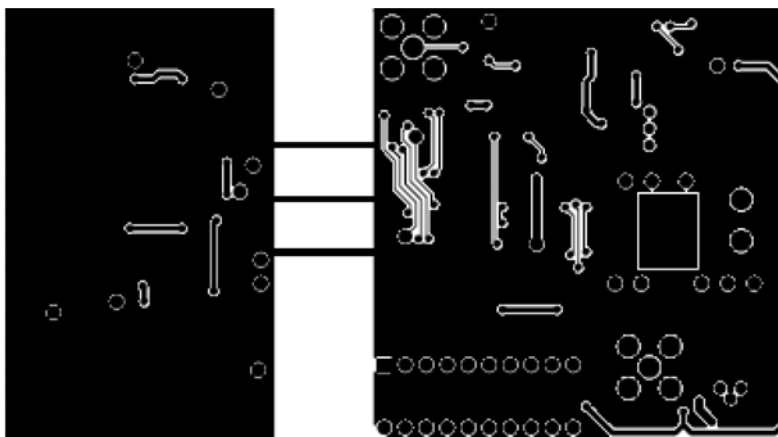

Figure 21. ADT7516 Evaluation Board PCB Layout (Solder Side)

# EVAL-ADT7516

## ORDERING INFORMATION

### BILL OF MATERIALS

Table 2. Parts List for EVAL-ADT7516EB Evaluation Board

Name	Part Type	Value	Tolerance	Part Description
AIN1 to AIN3	TESTPOINT			Red testpoint
C1, C2	CAP	22 pF		50 V NPO SMD ceramic capacitor
C3	CAP+	47 $\mu$ F		10 V SMD tantalum capacitor
C4	CAP+	2.2 $\mu$ F		10 V SMD tantalum capacitor
C5 to C10, C12 to C16, C18, C19, C21 to C30	CAP	0.1 $\mu$ F		16 V X7R multilayer ceramic capacitor
C11	CAP+	10 $\mu$ F		10 V SMD tantalum capacitor
C17	CAP	1 $\mu$ F		10 V DC Y5V ceramic capacitor
C20	CAP+	10 $\mu$ F		10 V SMD tantalum capacitor
D1	LED			Light emitting diode green
D2	LED			Light emitting diode red
J1	USB-MINI-B			USB Mini-B connector (usb-otg)
J2	CON\POWER			2 pin terminal block (5 mm pitch)
P1	SMB			50 $\Omega$ SMB jack
P2	SMB			50 $\Omega$ SMB jack
Q1	2N3906			PNP bipolar transistor
Q2	BC807-40LT1			Low power bipolar transistor
R1	RES	OR	1%	SMD resistor
R2, R4, R5, R11, R12, R15, R17, R21	RES	10 k $\Omega$	1%	SMD resistor
R3, R6	RES	100 k $\Omega$	1%	SMD resistor
R7, R20	RES	1 k $\Omega$	1%	SMD resistor
R13	RES	1.2 k $\Omega$	1%	SMD resistor
R14	RES	3.9 k $\Omega$	1%	SMD resistor
S1	SW-PUSH-SMD			SMD push button switch (sealed 6 mm x 6 mm)
T1 to T7, T9 to T11	TESTPOINT			Black testpoint
T8, T12 to T15	TESTPOINT			Red testpoint
U1	CY7C68013-CSP			USB Microcontroller
U2	ADP3303-3.3			Precision low dropout voltage regulator
U3	24LC64			64 k $\Omega$ I <sup>2</sup> C serial EEPROM
U4	ADG774			Low voltage quad SPDT switch
U5	TMP36			Low voltage temperature sensor
U6, U7	ADG604			CMOS 4-channel multiplexer
U8	LED_BAR_ARRAY			LED bar array
U9	ADT7516			Four channel ADC and quad voltage output DAC
U10, U11, U13	ADG821			Dual SPST switches
U12	LM3914			IC driver dot bar display 20PLCC
U14	TSL250R			Sensor, L/volts TSL250R TAOS
VOUTA to VOUTD	TESTPOINT			Red testpoint
Y1	XTAL-CM309S	24 MHz		Plastic SMD crystal

**ORDERING GUIDE**

Model	Description
EVAL-ADT7516EB	Evaluation Board

**ESD CAUTION**



**ESD (electrostatic discharge) sensitive device.** Charged devices and circuit boards can discharge without detection. Although this product features patented or proprietary protection circuitry, damage may occur on devices subjected to high energy ESD. Therefore, proper ESD precautions should be taken to avoid performance degradation or loss of functionality.

**EVAL-ADT7516**

**NOTES**