

Power Supply Built-in
Compact Multi-voltage Photoelectric Sensor

NX5 SERIES

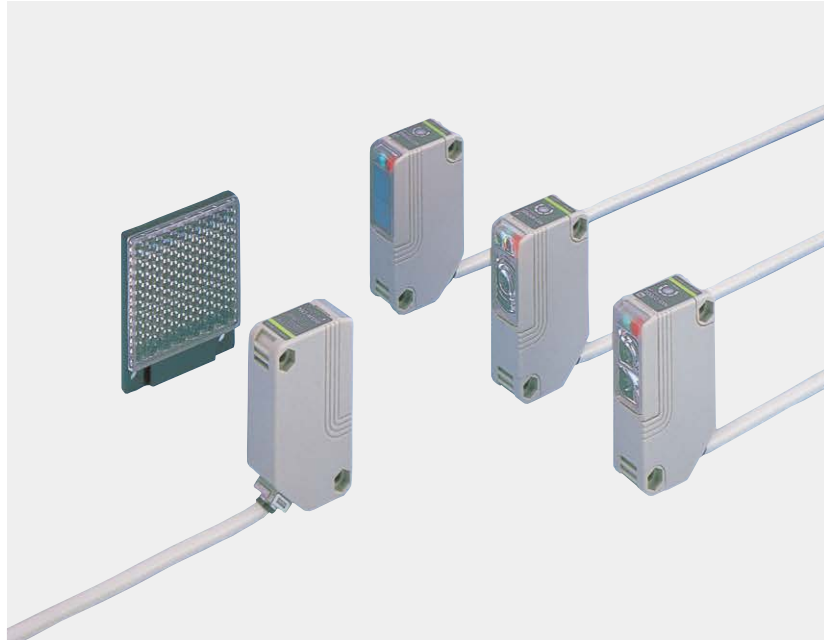

NX5 SERIES



*5 m 16.4041 ft cable length type:
Certified (for sales in China only)



Multi-voltage photoelectric sensor usable worldwide

Multi-voltage

The **NX5** series can operate at 24 to 240 V AC or 12 to 240 V DC, which is suitable for supply voltages around the world.

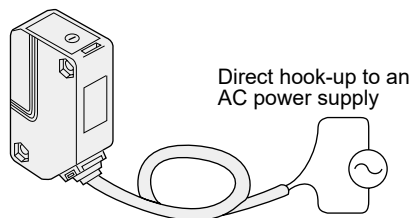

No need to arrange a DC power supply.

Compact size

Despite of being multi-voltage, it has a depth of just 35 mm 1.378 in. (W18 × H62 × D35 mm W0.709 × H2.441 × D1.378 in)

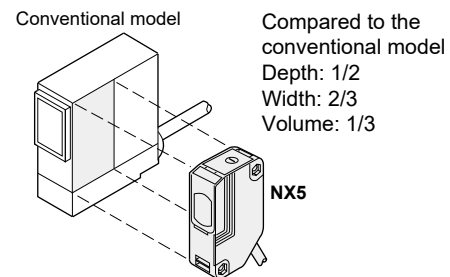

BASIC PERFORMANCE

Long sensing range

It is most suitable for conveyor lines and parking lot applications.

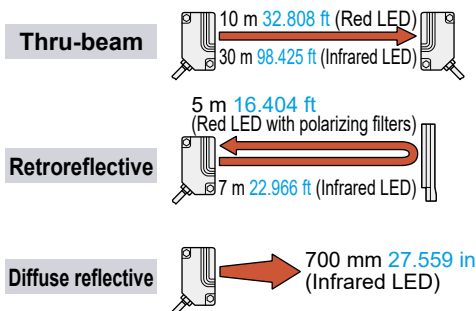

High reliability

It has an IP66 protection. Moderate dust or water splashes will not affect the sensor. The hermetically sealed output relay significantly increases its reliability.

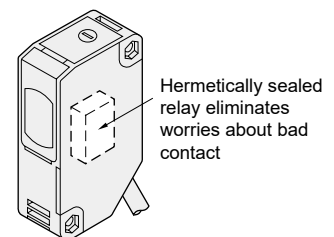

FUNCTIONS / MOUNTING

Easy alignment

The 10 m 32.808 ft thru-beam type sensor and the 5 m 16.404 ft retroreflective type sensor incorporate a red LED beam source. Beam alignment can be attained by checking the emitted beam visually.

Interference prevention

Two sensors can operate normally even if mounted close together. (Excluding the 30 m 98.425 ft thru-beam type sensor)

APPLICATIONS

Detecting objects on conveyor line

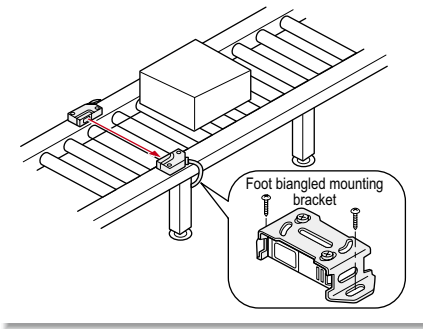

ORDER GUIDE

Type		Appearance	Sensing range	Model No. (Note 2, 3)	Emitting element	Output
Thru-beam	Light-ON		10 m 32.808 ft	NX5-M10RA	Red LED	Relay contact 1c
				NX5-M10RB		
	Dark-ON		30 m 98.425 ft	NX5-M30A	Infrared LED	
				NX5-M30B		
Retroreflective	With polarizing filters		0.1 to 5 m 0.328 to 16.404 ft (Note 1)	NX5-PRVM5A	Red LED	
				NX5-PRVM5B		
	Long sensing range		0.1 to 7 m 0.328 to 22.966 ft (Note 1)	NX5-RM7A	Infrared LED	
				NX5-RM7B		
Diffuse reflective	Light-ON		700 mm 27.559 in	NX5-D700A	Infrared LED	
	Dark-ON			NX5-D700B		

NOTE: Mounting bracket is not supplied with the sensor. Please select from the range of optional sensor mounting brackets (three types).

Notes: 1) The sensing range of the retroreflective type sensor is specified for the **RF-230** reflector. Further, the sensing range is the possible setting range for the reflector. The sensor can detect an object less than 0.1 m 0.328 ft away.

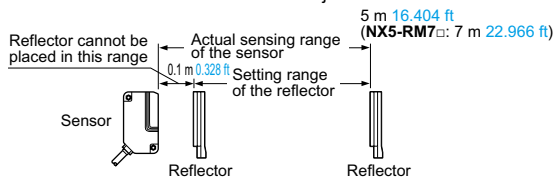

5 m 16.404 ft cable length type

5 m 16.404 ft cable length type (standard: 2 m 6.562 ft) is also available. When ordering this type, suffix **"-C5"** to the model No. (e.g.) 5 m 16.404 ft cable length type of **NX5-M10RA** is **"NX5-M10RA-C5"**.

- The model No. with **"P"** shown on the label affixed to the thru-beam type sensor is the emitter, **"D"** shown on the label is the receiver.
- Light-ON type sensor (model No. with suffix **"A"**) and Dark-ON type sensor (model No. with suffix **"B"**) are available in the **NX5** series. For the following models, in case of power off, the output relay condition is the same as when an object is detected. (In case of power supply line disconnection, the output operation is the same as when an object is detected.) Refer to **"I/O CIRCUIT DIAGRAM AND OUTPUT OPERATION (p.6)"** for the output operation of each model.

Accessory

- RF-230** (Reflector)



Thru-beam type	Retroreflective type	Diffuse reflective type
NX5-M10RA and NX5-M30A (Light-ON)	NX5-PRVM5A and NX5-RM7A (Light-ON)	NX5-D700B (Dark-ON)

OPTIONS

Designation	Model No.	Description
Sensor mounting bracket	MS-NX5-1	Foot angled mounting bracket (The thru-beam type sensor needs two brackets.)
	MS-NX5-2	Foot biangled mounting bracket (sensor protection bracket) (The thru-beam type sensor needs two brackets.)
	MS-NX5-3	Back angled mounting bracket (The thru-beam type sensor needs two brackets.)
Slit mask For thru-beam type sensor only	OS-NX5-3×6 (Slit size 3 × 6 mm 0.118 × 0.236 in)	Slit on one side <ul style="list-style-type: none"> • Sensing range: 3 m 9.843 ft [NX5-M10R□] 16 m 52.493 ft [NX5-M30□] • Min. sensing object: ø10 mm ø0.394 in [NX5-M10R□] ø20 mm ø0.787 in [NX5-M30□]
		Slit on both sides <ul style="list-style-type: none"> • Sensing range: 1 m 3.281 ft [NX5-M10R□] 6 m 19.685 ft [NX5-M30□] • Min. sensing object: 3 × 6 mm 0.118 × 0.236 in
Interference prevention filter For NX5-M10RA or NX5-M10RB only	PF-NX5-V (Vertical, Silver)	Same type of filters on both sides <ul style="list-style-type: none"> • Sensing range: 5 m 16.404 ft • Min. sensing object: ø20 mm ø0.787 in (One set consists of 2 pcs. of interference prevention filters.)
	PF-NX5-H (Horizontal, Light brown)	
Reflector For retro-reflective type sensor only	RF-210	<ul style="list-style-type: none"> • Sensing range: 0.1 to 1.5 m 0.328 to 4.921 ft [NX5-PRVM5□] 0.1 to 2.5 m 0.328 to 8.202 ft [NX5-RM7□] • Min. sensing object: ø30 mm ø1.181 in
	RF-220	<ul style="list-style-type: none"> • Sensing range: 0.1 to 3.5 m 0.328 to 11.483 ft [NX5-PRVM5□] 0.1 to 5 m 0.328 to 16.404 ft [NX5-RM7□] • Min. sensing object: ø35 mm ø1.378 in
Reflector mounting bracket	MS-RF21-1	Protective mounting bracket for RF-210 It protects the reflector from damage and maintains alignment.
	MS-RF22	For RF-220
	MS-RF23	For RF-230
Reflective tape For retro-reflective type sensor only	RF-11	<ul style="list-style-type: none"> • Ambient temperature: -25 to +50 °C -13 to +122 °F • Ambient humidity: 35 to 85 % RH Notes <ul style="list-style-type: none"> • Keep the tape free from stress. If it is pressed too much, its capability may deteriorate. • Do not cut the tape. It will deteriorate the sensing performance.
	RF-12	<ul style="list-style-type: none"> • Sensing range: 0.1 to 1 m 0.328 to 3.281 ft [NX5-PRVM5□] • Sensing range: 0.1 to 1.5 m 0.328 to 4.921 ft [NX5-RM7□]
Sensor checker	CHX-SC2	It is useful for beam alignment of thru-beam type sensors. The optimum receiver position is given by indicators, as well as an audio signal.

Sensor mounting bracket

- **MS-NX5-1** • **MS-NX5-2** • **MS-NX5-3**

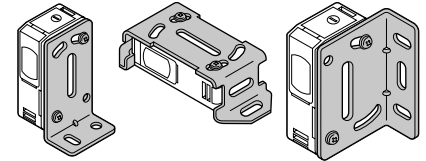

Two M4 (length 25 mm 0.984 in) screws with washers and two M4 nuts are attached. Two M4 (length 25 mm 0.984 in) screws with washers and two M4 nuts are attached. Two M4 (length 25 mm 0.984 in) screws with washers and two M4 nuts are attached.

Slit mask

- **OS-NX5-3×6**

Fitted on the front face of the sensor with one touch.

Interference prevention filter
(For NX5-M10R□ only)

- **PF-NX5-V**(Vertical, Silver color)
 - **PF-NX5-H**(Horizontal, Light brown)
- Two sets of thru-beam type sensors (Red LED type) can be mounted close together.

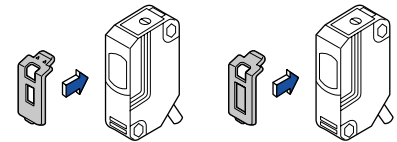

Reflector

- **RF-210** • **RF-220**

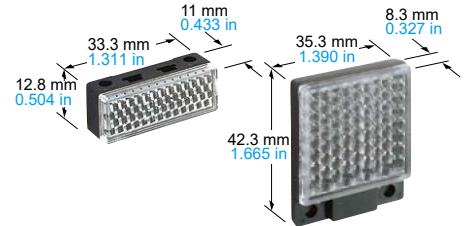

Reflector mounting bracket

- **MS-RF23** • **MS-RF22** • **MS-RF21-1**

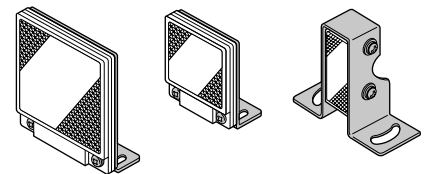

Two M4 (length 10 mm 0.394 in) screws with washers are attached. Two M3 (length 8 mm 0.315 in) screws with washers are attached. Two M3 (length 12 mm 0.472 in) screws with washers are attached.

Reflective tape

- **RF-11** • **RF-12**

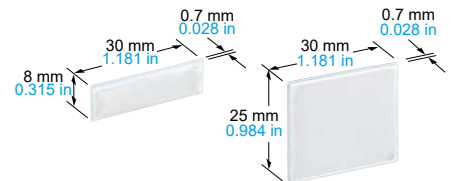

Sensor checker

- **CHX-SC2**

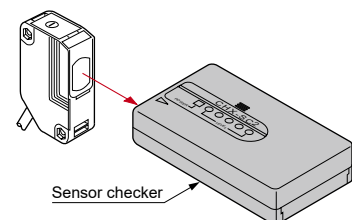

SPECIFICATIONS

Type	Thru-beam				Retroreflective				Diffuse reflective		
	Long sensing range		With polarizing filters		Long sensing range						
Item	Model No.	NX5-M10RA	NX5-M10RB	NX5-M30A	NX5-M30B	NX5-PRVM5A	NX5-PRVM5B	NX5-RM7A	NX5-RM7B	NX5-D700A	NX5-D700B
CE marking directive compliance	Low Voltage Directive, EMC Directive, RoHS Directive										
Sensing range	10 m 32.808 ft		30 m 98.425 ft		0.1 to 5 m 0.328 to 16.404 ft (Note 2)		0.1 to 7 m 0.328 to 22.966 ft (Note 2)		700 mm 27.559 in (Note 3)		
Sensing object	ø20 mm ø0.787 in or more opaque object (Note 4)		ø20 mm ø0.787 in or more opaque object (Completely beam interrupted object) (Note 4)		ø50 mm ø1.969 in or more opaque, translucent or specular object (Note 2, 5)		ø50 mm ø1.969 in or more opaque or translucent object (Note 2, 5)		Opaque, translucent or transparent object (Note 5)		
Hysteresis	_____										15 % or less of operation distance (Note 3)
Repeatability (perpendicular to sensing axis)	0.1 mm 0.004 in or less		0.2 mm 0.008 in or less				0.3 mm 0.012 in or less				
Supply voltage	24-240 V AC $+10_{-15}$ % or 12 to 240 V DC $+10_{-15}$ % Ripple P-P 10 % or less										
Power consumption	Emitter: 1 VA or less Receiver: 2 VA or less		Emitter: 1.5 VA or less Receiver: 2 VA or less		2 VA or less						
Output	Relay contact 1 c <ul style="list-style-type: none"> Switching capacity: 250 V AC 1 A (resistive load) 30 V DC 2 A (resistive load) Electrical life: 500,000 or more switching operations (switching frequency 3,600 operations/hour) 100,000 or more switching operations (switching frequency 3,600 operations/hour) Mechanical life: 100 million or more switching operations (switching frequency 36,000 operations/hour) 										
Output operation	Light-ON	Dark-ON	Light-ON	Dark-ON	Light-ON	Dark-ON	Light-ON	Dark-ON	Light-ON	Dark-ON	
Response time	10 ms or less										
Operation indicator	Red LED (lights up when the output is ON)										
Stability indicator	Green LED (lights up under stable light received condition or stable dark condition)										
Power indicator	_____		Red LED (lights up when the power is ON)		_____						
Sensitivity adjuster	Continuously variable adjuster		_____		Continuously variable adjuster		_____		Continuously variable adjuster		
Automatic interference prevention function	(Use optional interference prevention filters)		_____		Incorporated (Two units of sensors can be mounted close together.)						
Environmental resistance	Pollution degree	3 (Industrial environment)									
	Protection	IP66 (IEC)									
	Ambient temperature	-20 to +55 °C -4 to +131 °F (No dew condensation or icing allowed) (Note 6), Storage: -30 to +70 °C -22 to +158 °F									
	Ambient humidity	35 to 85 % RH, Storage: 35 to 85 % RH									
	Ambient illuminance	Incandescent light: 3,500 lx or less at the light-receiving face									
	Voltage withstandability	1,500 V AC for one min. between power supply and output terminals, 1,000 V AC for one min. between relay contact terminals									
	Insulation resistance	20 MΩ, or more, with 500 V DC megger between power supply and output terminals, and between relay contact terminals									
	Vibration resistance	10 to 55 Hz frequency, 1.5 mm 0.059 in double amplitude in X, Y and Z directions for two hours each									
	Shock resistance	500 m/s ² (50 G approx.) in X, Y and Z directions three times each									
Emitting element	Red LED (modulated)		Infrared LED (modulated)		Red LED (modulated)		Infrared LED (modulated)				
Peak emission wavelength	660 nm 0.026 mil		880 nm 0.035 mil		660 nm 0.026 mil		880 nm 0.035 mil				
Material	Enclosure: Polycarbonate, Lens: Polycarbonate, Cover: Polycarbonate, Front cover (retroreflective type sensor only): Acrylic										
Cable	0.3 mm ² 5-core (thru-beam type emitter: 2-core) cabtyre cable, 2 m 6.562 ft long										
Cable extension	Extension up to total 100 m 328.084 ft is possible with 0.3 mm ² , or more, cable (thru-beam type: both emitter and receiver).										
Net weight	Emitter: 100 g approx. Receiver: 140 g approx.		Emitter: 125 g approx. Receiver: 140 g approx.		140 g approx.						
Accessories	Adjusting screwdriver: 1 pc.		_____		RF-230 (Reflector): 1 pc. Adjusting screwdriver: 1 pc.		RF-230 (Reflector): 1 pc.		Adjusting screwdriver: 1 pc.		

Notes: 1) Where measurement conditions have not been specified precisely, the conditions used were an ambient temperature of +23 °C **+73.4 °F**.

- 2) The sensing range and the sensing object of the retroreflective type sensor is specified for the **RF-230** reflector. Further, the sensing range is the possible setting range for the reflector.
The sensor can detect an object less than 0.1 m **0.328 ft** away.

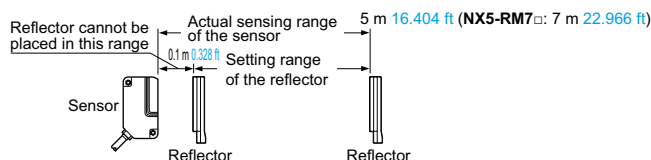

- 3) The sensing range and the hysteresis of the diffuse reflective type sensor are specified for white non-glossy paper (200 × 200 mm **7.874 × 7.874 in**) as the object.
4) If slit masks (optional) are fitted, an object as small as 3 × 6 mm **0.118 × 0.236 in** can be detected.
5) Make sure to confirm detection with an actual sensor before use.
6) In case the sensor is to be used at an ambient temperature of -15 °C **+5 °F**, or less, please contact our office.

I/O CIRCUIT DIAGRAM AND OUTPUT OPERATION

I/O circuit diagram

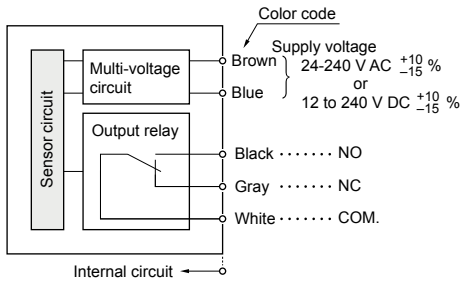

Note: The emitter of the thru-beam type sensor has two wires for power (+V and 0 V) only.

Output operation

: Object detected state.

Sensing mode	Thru-beam & Retroreflective type				Diffuse reflective type			
	Light-ON (A) type		Dark-ON (B) type		Light-ON (A) type		Dark-ON (B) type	
Output	NO (Black cable)	NC (Gray cable)	NO (Black cable)	NC (Gray cable)	NO (Black cable)	NC (Gray cable)	NO (Black cable)	NC (Gray cable)
Power OFF	Open	Close	Open	Close	Open	Close	Open	Close
Beam-received	Close	Open	Open	Close	Close	Open	Open	Close
Beam-interrupted	Open	Close	Close	Open	Open	Close	Close	Open

SENSING CHARACTERISTICS (TYPICAL)

NX5-M10RA NX5-M10RB

Thru-beam type

Parallel deviation

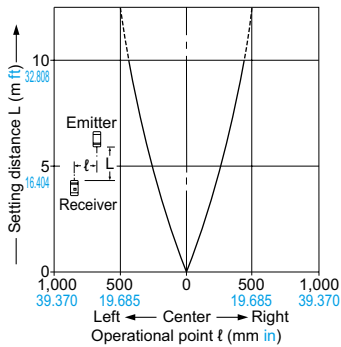

Angular deviation

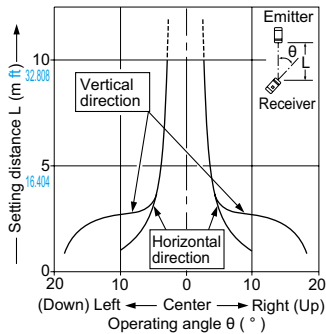

Parallel deviation with slit masks (3 x 6 mm 0.118 x 0.236 in)

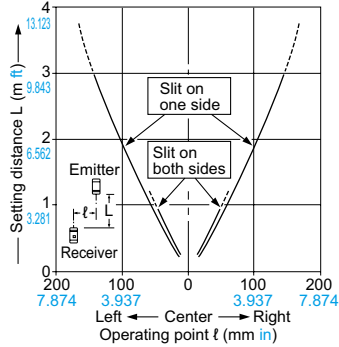

NX5-M30A NX5-M30B

Thru-beam type

Parallel deviation

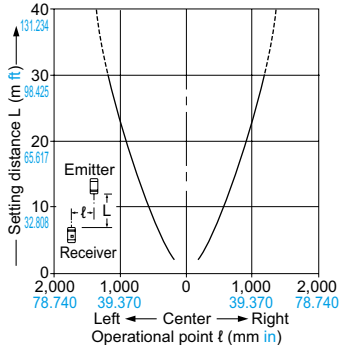

Angular deviation

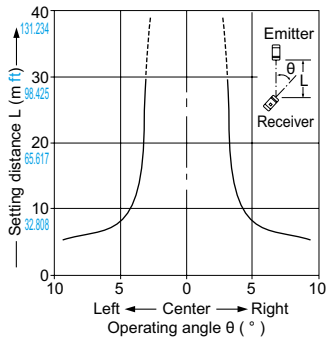

Parallel deviation with slit masks (3 x 6 mm 0.118 x 0.236 in)

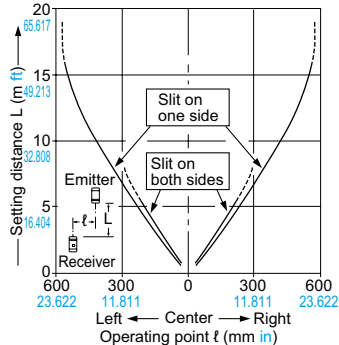

SENSING CHARACTERISTICS (TYPICAL)**NX5-PRVM5A NX5-PRVM5B**

Retroreflective type

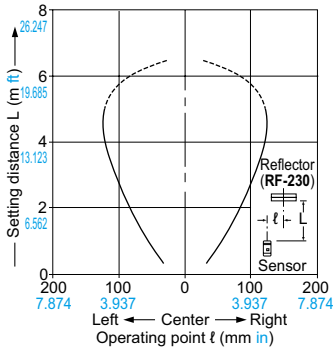
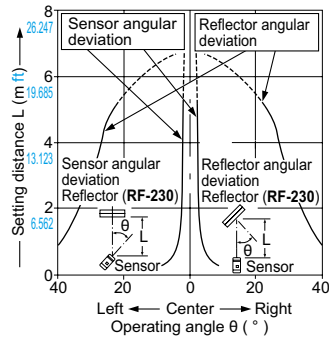
Parallel deviation**Angular deviation****NX5-RM7A NX5-RM7B**

Retroreflective type

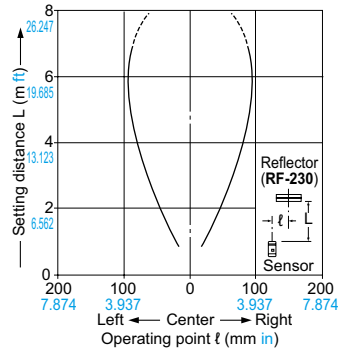
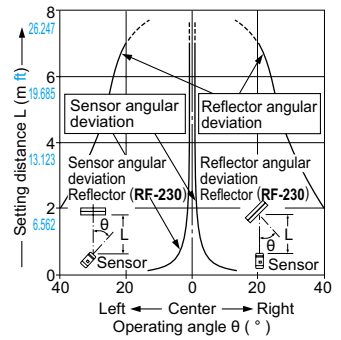
Parallel deviation**Angular deviation****NX5-D700A NX5-D700B**

Diffuse reflective type

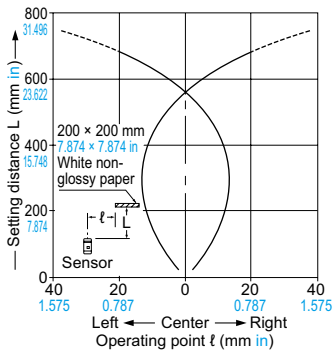
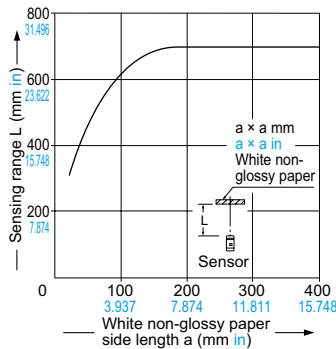
Sensing field**Correlation between sensing object size and sensing range**

As the sensing object size becomes smaller than the standard size (white non-glossy paper 200 × 200 mm 7.874 × 7.874 in), the sensing range shortens, as shown in the left graph.

(For plotting the left graph, the sensitivity has been set such that a 200 × 200 mm 7.874 × 7.874 in white non-glossy paper is just detectable at a distance of 700 mm 27.559 in.)

PRECAUTIONS FOR PROPER USE

- Never use this product as a sensing device for personnel protection.
- In case of using sensing devices for personnel protection, use products which meet laws and standards, such as OSHA, ANSI or IEC etc., for personnel protection applicable in each region or country.

Others

- Do not use during the initial transient time (50 ms) after the power supply is switched on.
- Although the protection degree is specified for the sensor including the cable, the cable end is not waterproof, and is not covered by the protection specified. Hence, make sure that water does not seep in from the cable end.

Mounting

- The tightening torque should be 0.8 N·m or less.

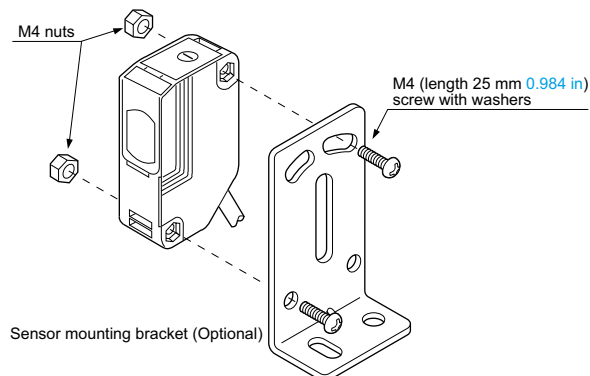
**Interference prevention filter (Exclusively for NX5-M10R□)**

- Use the interference prevention filters (optional) when two units of thru-beam type sensors are mounted close together. However, take note that the sensing range will become short.
- There are 2 types of interference prevention filters. Install **PF-NX5-H** (Horizontal, Light brown) for 1 set, and install **PF-NX5-V** (Vertical, Silver color) for the other set.

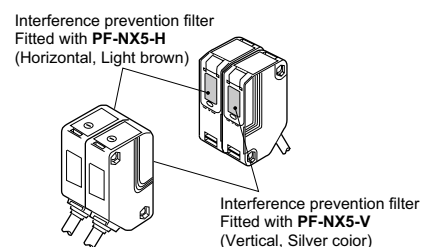

Note: The filters cannot be used for **NX5-M30A** or **NX5-M30B**.

PRECAUTIONS FOR PROPER USE

Retroreflective type sensor (NX5-RM7□)

- Please take care of the following points when detecting materials having a gloss.

- ① Make L, shown in the diagram, sufficiently long.
- ② Install at an angle of 10 to 30 degrees to the sensing object.

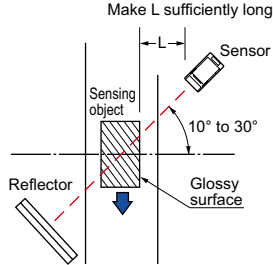

* **NX5-PRVM5□** does not need the above adjustment.

Retroreflective type sensor with polarizing filters (NX5-PRVM5□)

- If a shiny object is covered or wrapped with a transparent film, such as those described below, the retroreflective type sensor with polarizing filters may not be able to detect it.

In that case, follow the steps given below.

Example of sensing objects

- Can wrapped by clear film
- Aluminum sheet covered by plastic film
- Gold or silver color (specular) label or wrapping paper

Steps

- Tilt the sensor with respect to the sensing object while fitting.
- Reduce the sensitivity.
- Increase the distance between the sensor and the sensing object.

DIMENSIONS (Unit: mm in)

The CAD data can be downloaded from our website.

NX5-M10RA NX5-M10RB NX5-M30A NX5-M30B Sensor

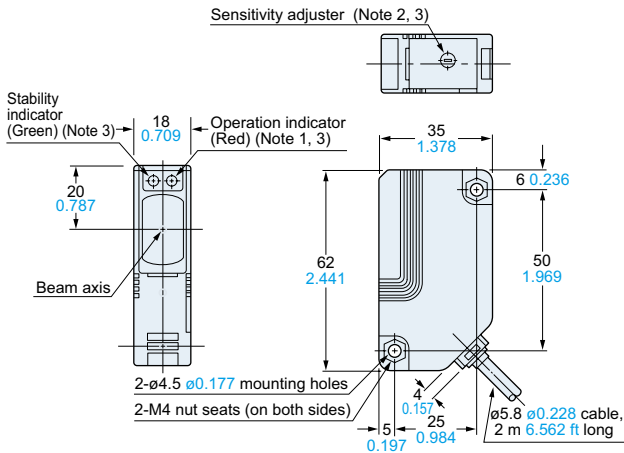

- Notes: 1) It is the power indicator (red) on the emitter of **NX5-M30□**.
 2) Not incorporated on **NX5-M30□**.
 3) Not incorporated on the emitter.

NX5-PRVM5A NX5-PRVM5B NX5-RM7A NX5-RM7B Sensor

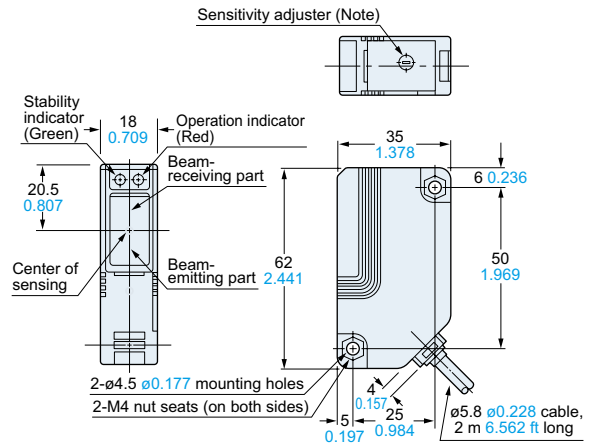

Note: Not incorporated on **NX5-RM7□**.

NX5-D700A NX5-D700B Sensor

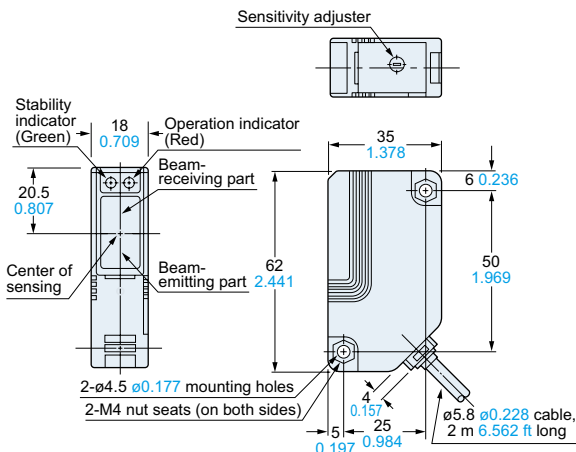

DIMENSIONS (Unit: mm in)

The CAD data can be downloaded from our website.

RF-230 Reflector (Accessory for the retroreflective type sensor)

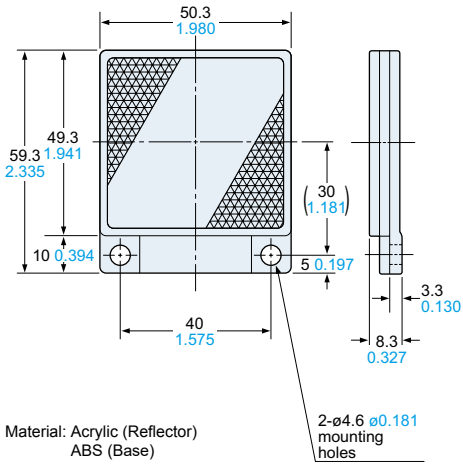

RF-220 Reflector (Optional)

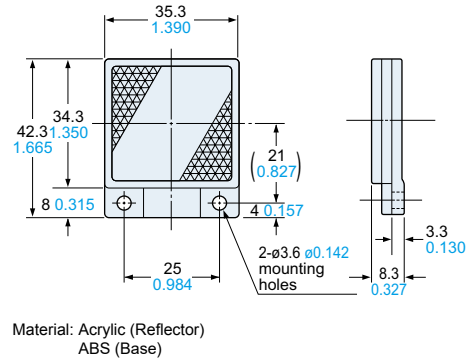

RF-210 Reflector (Optional)

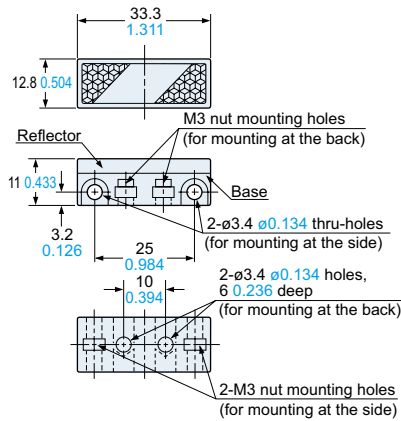

Material: Acrylic (Reflector)
ABS (Base)
Two M3 (length 8 mm 0.315 in)
screws with washers and two nuts are attached.

RF-11 Reflective tape (Optional)

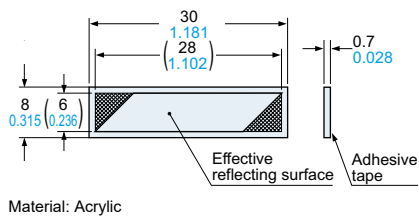

RF-12 Reflective tape (Optional)

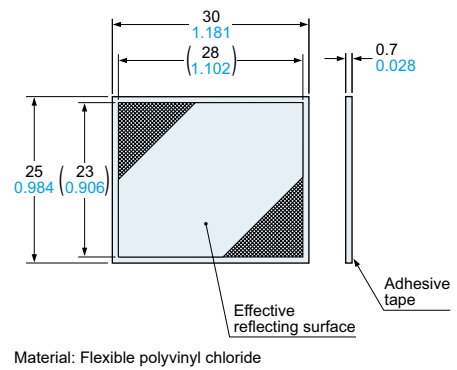

DIMENSIONS (Unit: mm in)

The CAD data can be downloaded from our website.

MS-NX5-1

Sensor mounting bracket (Optional)

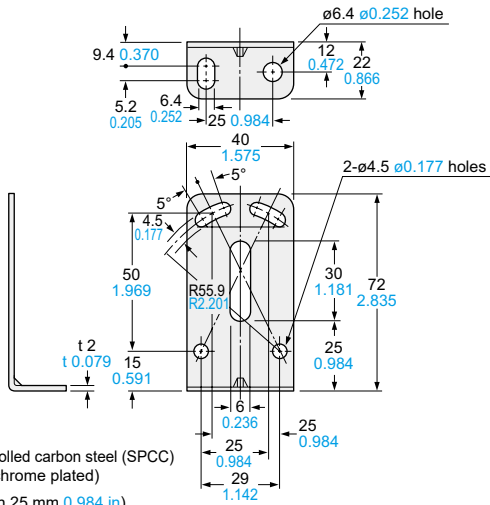

Assembly dimensions

Mounting drawing with the receiver of **NX5-M10R**□

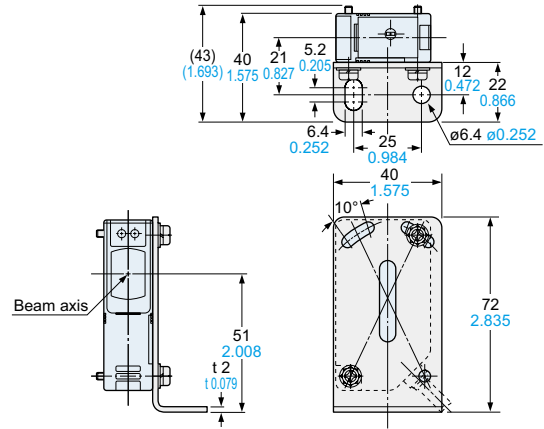

MS-NX5-2

Sensor mounting bracket (Optional)

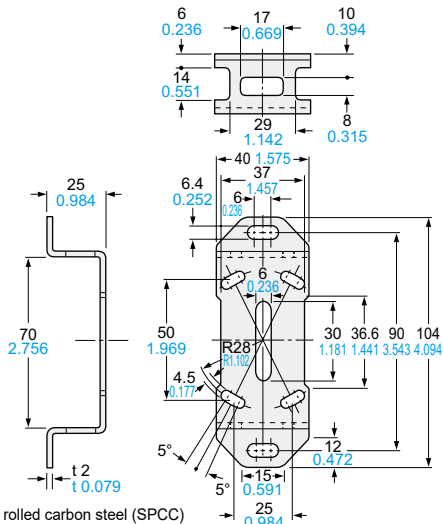

Assembly dimensions

Mounting drawing with the receiver of **NX5-M10R**□

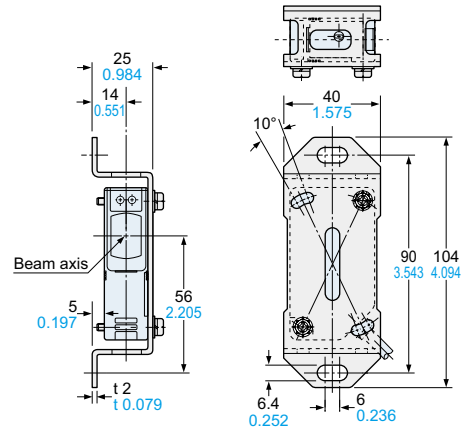

MS-NX5-3

Sensor mounting bracket (Optional)

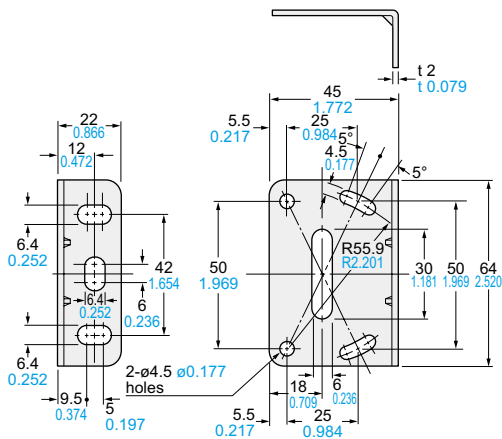

Assembly dimensions

Mounting drawing with the receiver of **NX5-M10R**□

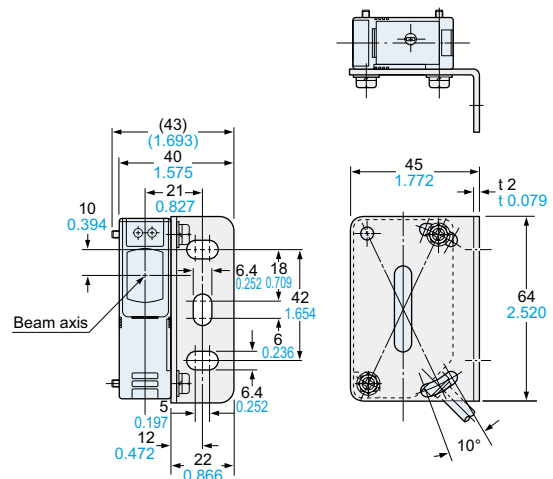

DIMENSIONS (Unit: mm in)

The CAD data can be downloaded from our website.

MS-RF21-1

Reflector mounting bracket for **RF-210** (Optional)

Assembly dimensions

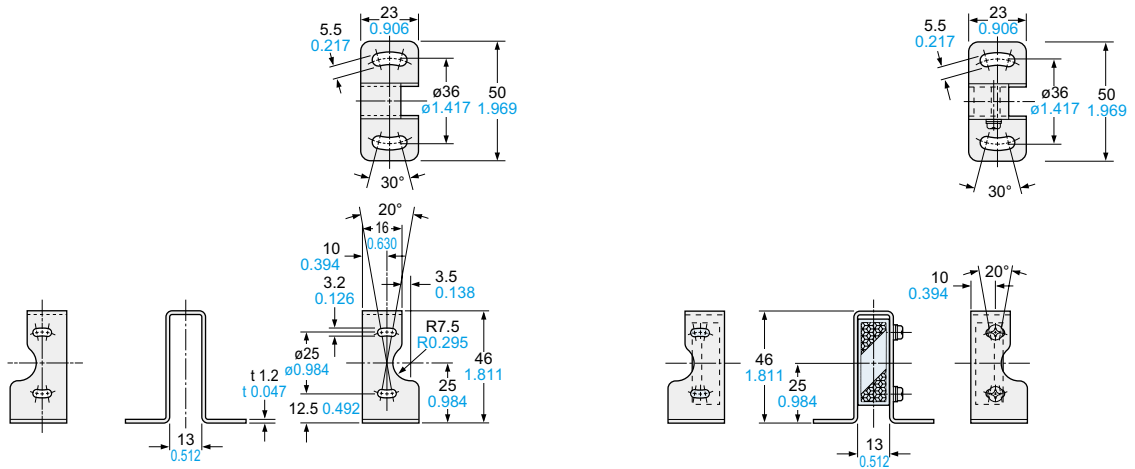

Material: Stainless steel (SUS304)
Two M3 (length 12 mm 0.472 in) screws with washers are attached.

MS-RF22

Reflector mounting bracket for **RF-220** (Optional)

Assembly dimensions

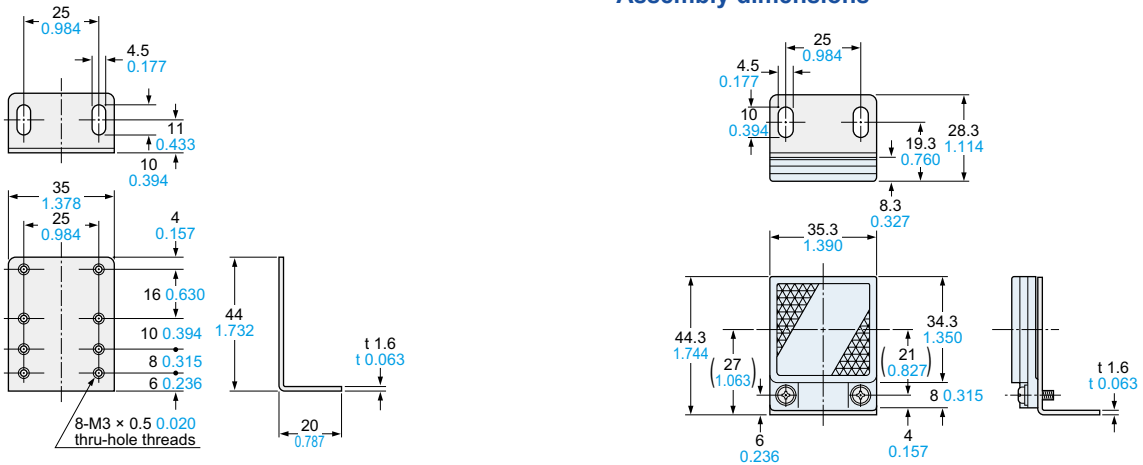

Material: Cold rolled carbon steel (SPCC)
(Uni-chrome plated)
Two M3 (length 8 mm 0.315 in) screws with washers are attached.

MS-RF23

Reflector mounting bracket for **RF-230** (Optional)

Assembly dimensions

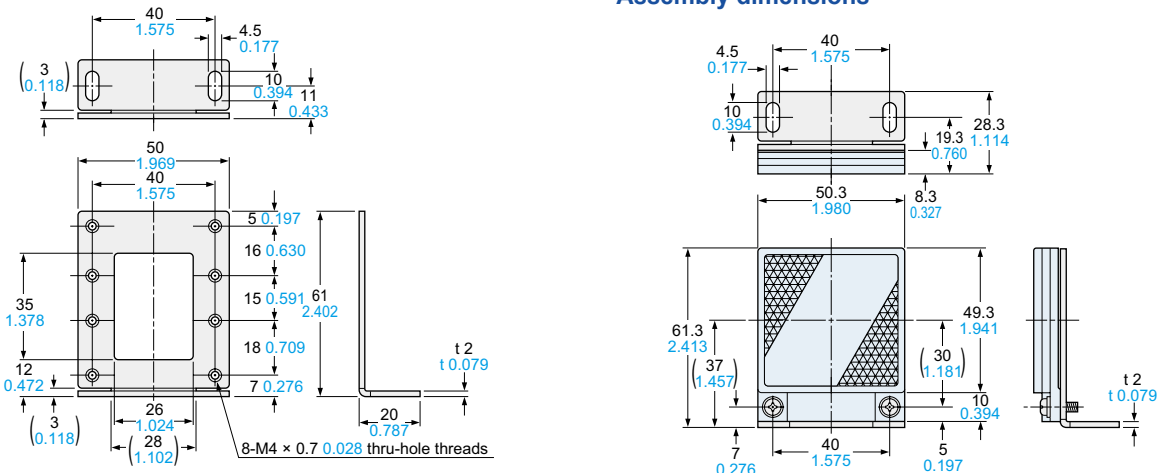

Material: Cold rolled carbon steel (SPCC)
(Uni-chrome plated)
Two M4 (length 10 mm 0.394 in) screws with washers are attached.

Disclaimer

The applications described in the catalog are all intended for examples only. The purchase of our products described in the catalog shall not be regarded as granting of a license to use our products in the described applications. We do NOT warrant that we have obtained some intellectual properties, such as patent rights, with respect to such applications, or that the described applications may not infringe any intellectual property rights, such as patent rights, of a third party.

Panasonic
INDUSTRY

Panasonic Industry Co., Ltd.

Industrial Device Business Division

7-1-1, Morofuku, Daito-shi, Osaka 574-0044, Japan

industrial.panasonic.com/ac/e/