

UNCONTROLLED DOCUMENT

PART NUMBER
SSP-LXC0947U13A

REV.
C

REV.	E.C.N. NUMBER AND REVISION COMMENTS	DATE
A	E.C.N. #10556.	10.13.99
B	E.C.N. #10582.	1.14.00
C	E.C.N. #10650.	8.16.00

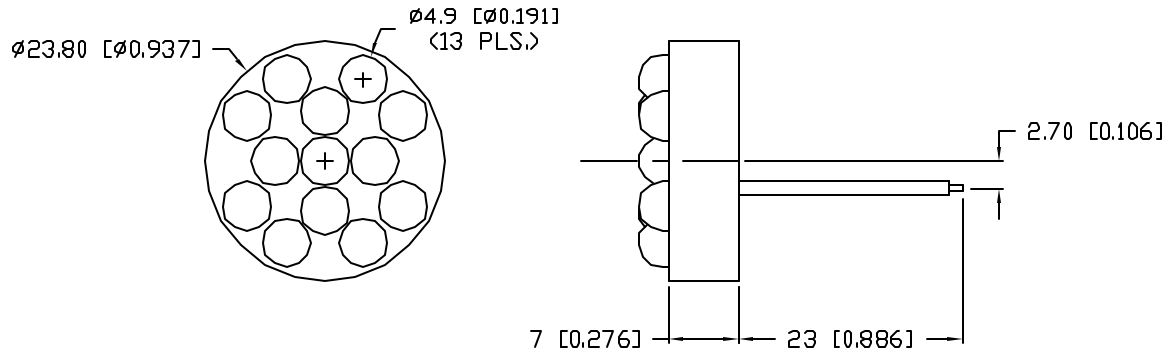

ELECTRO-OPTICAL CHARACTERISTICS $T_A=25^\circ\text{C}$ $I_f=20/40\text{mA}$

PARAMETER	MIN	TYP	MAX	UNITS	TEST COND
PEAK WAVELENGTH		470		nm	
FORWARD VOLTAGE*		17.5/14	20/16	V_f	
REVERSE VOLTAGE	5.0			V_r	$I_r=100\mu\text{A}$
AXIAL INTENSITY**		2000		mcd	$I_f=20/40\text{mA}$
VIEWING ANGLE		30		2x theta	

EMITTED COLOR: ULTRA BLUE
EPOXY LENS FINISH: WATER CLEAR

* VOLTAGE FOR: PIN 1/PIN 3

** INTENSITY PER DIE. TEST CONDITION: CURRENT FOR PIN 1/PIN 3

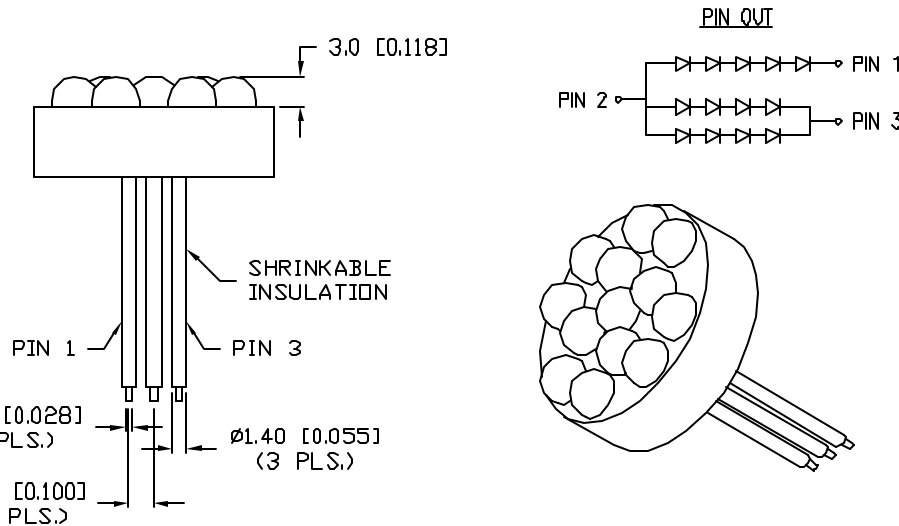

LIMITS OF SAFE OPERATION AT 25°C PER DIE

PARAMETER	MAX	UNITS
PEAK FORWARD CURRENT*	100	mA
STEADY CURRENT	30	mA
POWER DISSIPATION	98	mW
DERATE FROM 25°C	-1.0	mW/°C
OPERATING, STORAGE TEMP.	-30 TO +70	°C
SOLDERING TEMP.	+260	°C
2.0mm FROM BODY		3 SEC. MAX

* $t < 10\mu\text{s}$

CAUTION: STATIC SENSITIVE DEVICE
FOLLOW PROPER E.S.D. HANDLING PROCEDURES
WHEN WORKING WITH THIS PART.
ESD CLASSIFICATION: CLASS II BASED ON MIL-STD 883E.

*UNLESS OTHERWISE SPECIFIED TOLERANCES PER DECIMAL PRECISION ARE: X=±1 (±0.039), X.X=±0.5 (±0.020), X.XX=±0.25 (±0.010), X.XXX=±0.127 (±0.005). LEAD SIZE=±0.05 (±0.002), LEAD LENGTH=±0.75 (±0.030), MIN= ^{+DECIMAL PRECISION} -0.00 MAX= ^{+0.00} -DECIMAL PRECISION

UNCONTROLLED DOCUMENT

REV. C PART NUMBER SSP-LXC0947U13A

CONFIDENTIAL INFORMATION
THE INFORMATION CONTAINED IN THIS DOCUMENT IS THE PROPERTY OF SUNBRITE LEDS. EXCEPT AS SPECIFICALLY AUTHORIZED IN WRITING BY SUNBRITE LEDS, THE HOLDER OF THIS DOCUMENT SHALL KEEP ALL INFORMATION CONTAINED HEREIN CONFIDENTIAL AND SHALL PROTECT SAME IN WHOLE OR IN PART FROM DISCLOSURE AND DISSEMINATION TO ALL THIRD PARTIES.



286 E. HELEN ROAD
PALATINE, IL 60067-6976
PHONE: +1.847.359.2790
FAX: +1.847.359.2867
WEB: www.sunbriteleds.com

0.94" CIRCULAR, 13 LED POLYLED,
470nm InGaN/SiC BLUE LEDES, WATER CLEAR LENS.

RELIABILITY NOTE
DUR MANY YEARS OF EXPERIENCE DATA ACCUMULATION INDICATE THAT SOLDER HEAT IS A MAJOR CAUSE OF EARLY AND FUTURE FAILURE. PLEASE PAY ATTENTION TO YOUR SOLDERING PROCESS.

DRAWN: BC CHECKED: APPROVED: DATE: 9.21.99
PAGE: 1 OF 1