

ENG.NO.	a	b	d	e	WIRE RANGE	INS.DIA.	Q'TY/REEL
35725-4510	2.7	3.0	4.6	4.4	AWG #22-#18	1.5-3.0	5,000

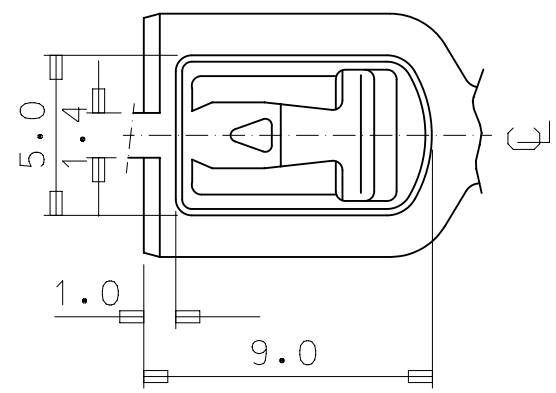

- NOTES
1. MATERIAL: BRASS 0.40 THICKNESS
 2. FINISH: PRE-TIN PLATING
 3. MATING TAB THICKNESS: 0.8
 4. RECOMMENDED LENGTH OF WIRE STRIP IS 5.5-6.0

ASS'Y PART		QTY/ REEL OR PACK	SURFACE AREA MM ²	WIRE RANGE AWG:
DESCRIPTION	ENG.NO.			
---	---	---	---	---
		DIE NO.	LAYOUT NO.	MM ² :
		---	---	---
		WIRE CRIMP WIDTH	INS. CRIMP WIDTH	INSULATION RANGE
		---	---	---
DIE FEED	APPL FEED	WBDW	IBDW	
21.5	21.5	---	---	---

THIS DRAWING CONTAINS INFORMATION THAT IS PROPRIETARY TO MOLEX ELECTRONIC TECHNOLOGIES, LLC AND SHOULD NOT BE USED WITHOUT WRITTEN PERMISSION

DIMENSION UNITS	SCALE	CURRENT REV DESC: OBSOLETE PART NO	
mm	4:1	<p>.250 SAFE LOCK RECEPTACLE</p> <p>PRODUCT CUSTOMER DRAWING</p>	
GENERAL TOLERANCES (UNLESS SPECIFIED)			
	MM INCH		
4 PLACES	± 0.3 ±		
3 PLACES	± 0.3 ±		
2 PLACES	± 0.3 ±	EC NO: 625872	2019/06/13
1 PLACE	± 0.3 ±	DRWN: AKUMAR19	2019/11/06
0 PLACES	± 0.3 ±	CHK'D: GB	2019/11/12
ANGULAR TOL	± 0.5°	APPR: GGA	
DRAFT WHERE APPLICABLE MUST REMAIN WITHIN DIMENSIONS	THIRD ANGLE PROJECTION	INITIAL REVISION:	1994/05/19
		DRWN: W.Y.YANG	
		APPR:	
		SERIES	35725
		MATERIAL NUMBER	SEE TABLE
		CUSTOMER	
		DOC TYPE	PSD
		DOC PART	001
		REVISION	C
		SHEET NUMBER	1 OF 1