

P/N OF ADAPTER	MATERIAL OF SLEEVE	TYPE	COLOR
106166-0500	ZR	SINGLE MODE	BLUE
106167-0500	PHOSPHOR BRONZE		
106166-0510	ZR	MULTIMODE	BEIGE
106167-0510	PHOSPHOR BRONZE		
106167-0710	PHOSPHOR BRONZE		
106166-0530	ZR		BLACK
106167-0530	PHOSPHOR BRONZE		
106166-0540	ZR	SINGLE MODE	RED
106167-0540	PHOSPHOR BRONZE	APC	GREEN
106166-0550	ZR		
106167-0550	PHOSPHOR BRONZE		

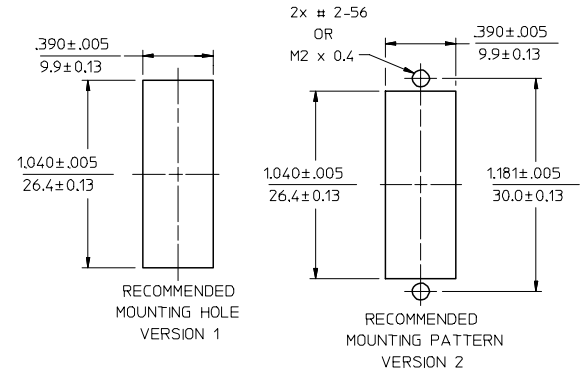
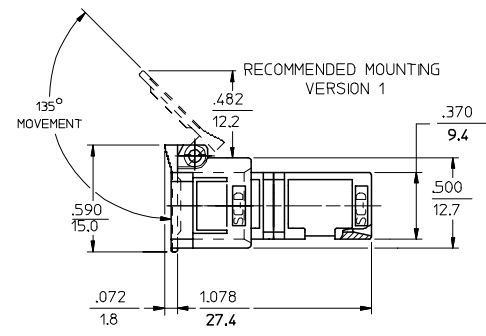
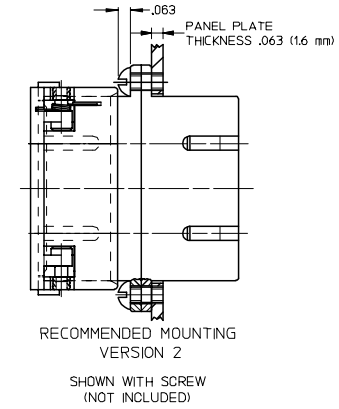
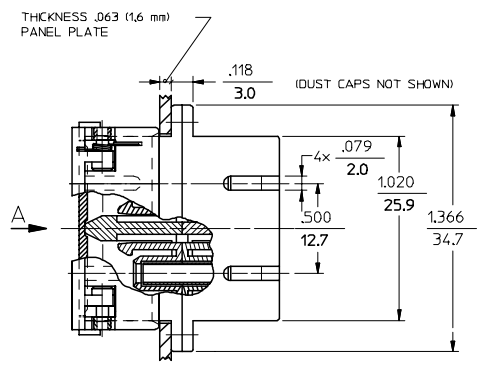
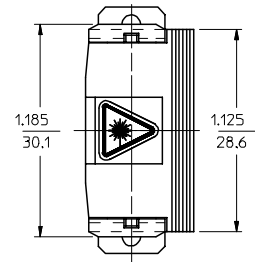

NOTES:  
1. LABEL MUST BE INSTALLED AND ORIENTED BY CUSTOMER. (SEE VIEW A)  
2. DUST CAPS ARE NOT SHOWN BUT INCLUDED.

ENTER DESCRIPTION FC NO: MF2006-0237 DRAWN: PGBLIN 2005/11/29 CHKD: 2005/11/29 APPR: JGUMIN 2005/11/29 REVISIONS A	QUALITY SYMBOLS ▽=0 ▽=0	GENERAL TOLERANCES (UNLESS SPECIFIED)		DIMENSION STYLE IN/MM		SCALE 4:1	DESIGN UNITS INCH	THIRD ANGLE PROJECTION	
		4 PLACES ± --- ± --- 3 PLACES ± --- ± --- 2 PLACES ± --- ± --- 1 PLACE ± --- ± ---	mm INCH	DRAWN BY RPACIFICI	DATE 2005/10/11	TITLE SC DUPLEX ADAPTER WITH SHIELD (SC-D)			
		ANGULAR ±1/2°		CHECKED BY	DATE	APPROVED BY			
		DRAFT WHERE APPLICABLE MUST REMAIN WITHIN DIMENSIONS		MATERIAL NO. SEE TABLE	DOCUMENT NO. SD-10616X-05X0	SHEET NO. 1 OF 1			