

12038VA (E-Type)

DC Axial Fan

120[□]X38^L



General Specifications

Motor Protection : Auto Restart / Polarity Protection

Insulation Resistance : 10MΩ or over with a DC500V Megger
 Dielectric Withstand Voltage : AC700V 1s
 : M, N, P, Q Class : -10°C ~ +70°C (Operating)

Allowable Ambient Temperature Range : R Class : -10°C ~ +60°C (Operating)
 : -40°C ~ +70°C (Storage)
 non-condensing environment

Outline

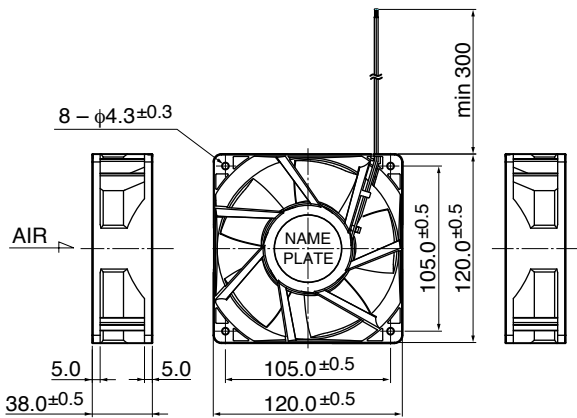

* Outline is E (Flange) type.

Expected Life

※ Failure Rate: 10% (L10 Life)

60°C 40,000 (Hours)

Panel Out-cuts

(Inlet Side)

(Outlet Side)

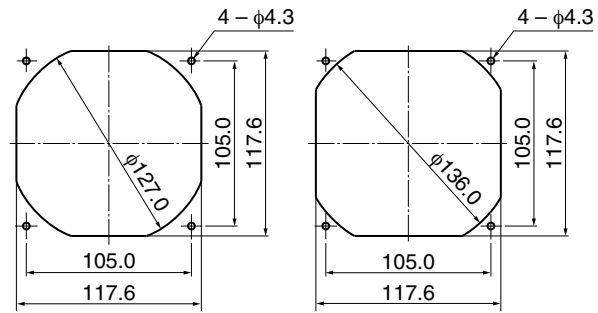

Characteristic Curves

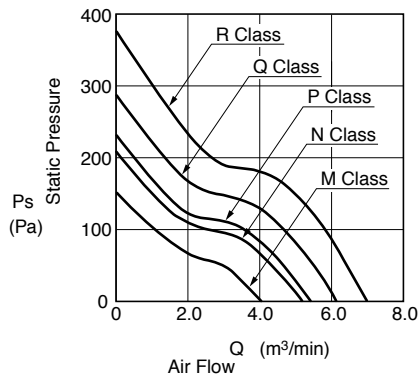

Material

Casing : Plastic (Black) UL94V-0
 Impeller : Plastic (Black) UL94V-0
 Bearing : Ball Bearing
 Lead Wire : UL10368 AWG24 + : Red, - : Black

Customize service for IP compatible type and Oil-proof type is available for this item. Please contact to our sales representative for more detail.

Specifications

□ = Casing Form --- A: Rib Type, E: Flange Type

Model	Product No.	Rating Voltage	Operating Voltage	Current (A) ^{*1}	Input Power (W) ^{*1}	Speed (min ⁻¹) ^{*1}	Max. Air Flow		Max. Static Pressure		Noise (dB) ^{*1}	Mass (g)
		(V)	(V)				(m³/min) ^{*1}	(CFM) ^{*1}	(Pa) ^{*1}	(In H ₂ O) ^{*1}		
12038VA-24M-□AE-	0	24	18.0 ~ 27.6	0.45	10.80	3800	4.00	141.2	150.0	0.60	53.0	370
12038VA-24N-□AE-	0			0.74	17.76	4700	5.17	182.6	207.0	0.83	59.0	
12038VA-24P-□AE-	0			0.74	17.76	5000	5.35	188.9	235.0	0.94	60.0	
12038VA-24Q-□AE-	0			1.04	24.96	5700	6.11	215.7	287.0	1.15	63.0	
12038VA-24R-□AE-	0			1.48	35.52	6400	6.90	243.6	370.0	1.49	66.0	

Rotation: Clockwise as seen from the label side
 Airflow Outlet: Label side

*1: Average Values in Free Air

General Specifications

Motor Type: DC Brushless Motor

Motor Protection: Auto Restart/Polarity Protection

Motor withstands reverse connection for positive and negative leads.

Insulation Resistance:

10M Ω or over with a DC500V Megger

Dielectric Withstand Voltage:

AC 700V 1s or 500V 1min

Allowable Ambient Temperature Range:

-10°C ~ +60°C (Operating)

-40°C ~ +60°C (Storage)

(non-condensing environment)

Characteristics Curves

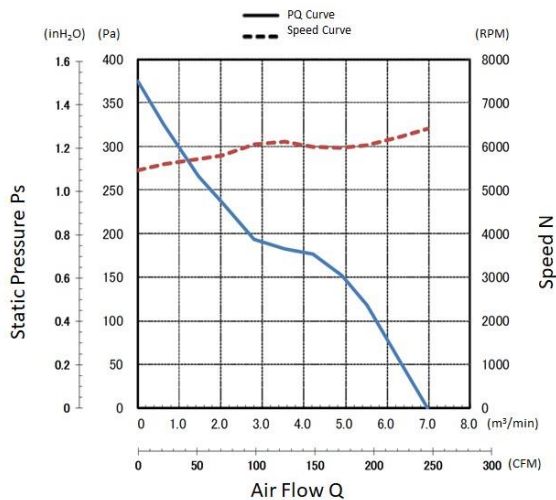

PWM Benefits & Applications

PWM Benefits

- Increased Life Expectancy
- Energy Saving
- Lower Vibration
- Lower Noise
- Current Spike Prevention

PWM Applications

- Routers
- Switches
- Storage
- Data Centers
- Optical Repeaters
- Broadcast Equipment
- Inverters
- UPS
- Battery Chargers
- Fuel Cells
- Industrial Power Supplies
- Welders
- Plasma Cutters
- Instrumentation
- Test Equipment
- Enclosures and more

- Customized fan performances at multiple operating points.
- Peak efficiency resulting in lower total ownership costs.
- Cost effective and better reliability.

Life Expectancy L10

60°C 40,000 Hours

Specifications

MODEL	Rated Voltage	Operating Voltage	Current		Input Power		Speed	Max. Air Flow		Max. Static Pressure		Noise	Mass
	(V)	(V)	Avg	Max	Avg	Max		(CFM)	(m³/min)	(inH ₂ O)	(Pa)		
	(V)	(V)	(A) ^{*1}	(A) ^{*1}	(W) ^{*1}	(W) ^{*1}	(min ⁻¹) ^{*1}	(CFM)	(m³/min)	(inH ₂ O)	(Pa)	(dB) ^{*1}	(g)
12038VA-24R-FU-6	24	18.0 ~ 27.6	1.48	1.77	35.52	42.48	6400	243.7	6.90	1.49	370	64.0	370

*1: Values in Free Air

PWM Specifications

PWM CONTROL CONNECTION

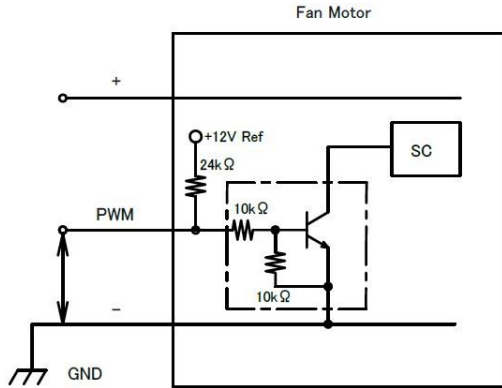

1. PWM Control

- V_{st} = Low Level (0V~0.4V) → Stop (On Duty 0%)
- V_{st} = High Level → Full Speed (On Duty 100%)
- V_{st} = Open → Full Speed

2. PWM Duty & PWM Input Pulse

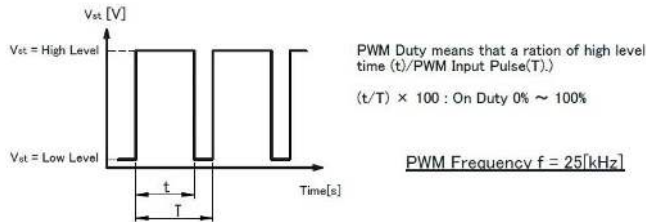

TACHO Specifications

TACHO SIGNAL

1. OUTPUT CIRCUIT : OPEN COLLECTOR
2. SPECIFICATION

T_a=25°C

Absolute Maximum Ratings at T_a=25°C

V_{CE} max : +30V

I_c max : 5mA [V_{CE}(sat)max = 0.5V]

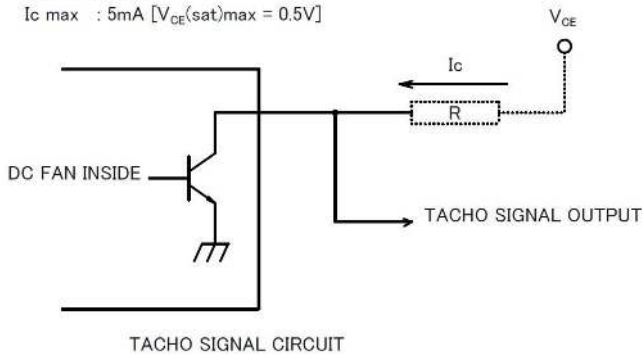

PWM Characteristics Curve

Reference PWM Duty VS Speed

Conditions: at rating Voltage, V_{st}=5.0V, f=25kHz, T_a=25°C

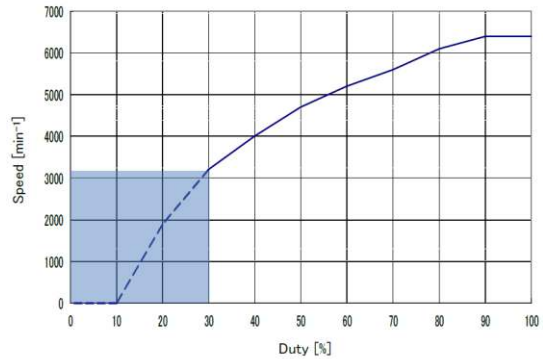

3. The condition for PWM control are as follows.

- When you use this under PWM control, always be sure the motor's operation under practical mounting state. Fan motor may not start up caused by PWM control at very low speed condition.
- To run at Rating Voltage.
- Please use the start with Duty 30% or more at 25kHz. [At rated voltage input, Ambient temperature 25°C]

3. OUTPUT WAVEFORM : AT RATED VOLTAGE

4. OUTPUT SIGNAL VOLTAGE

3-1 Case-1

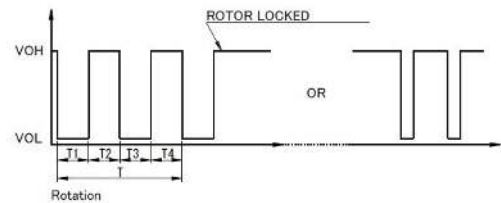

3-2 Case-2

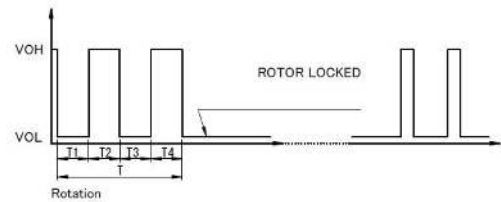

1) When the rotor is locked at VOH position of signal, signal keeps VOH position or signal becomes to VOL position for a few seconds at any time of the auto-restart motion.

2) When the rotor is locked at VOL position of signal, signal keeps VOL position or signal becomes to VOH position for a few seconds at any time of the auto-restart motion.

3) T = T1 + T2 + T3 + T4 = 60 / m / rotation

m : min⁻¹

Tach Duty Cycle = 50% ± 10%

Panel Cut-Outs

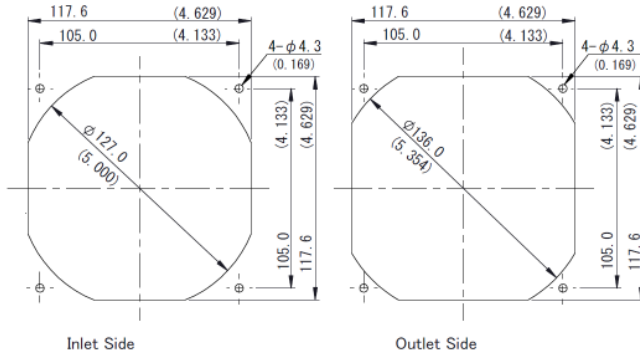

Unit: mm (inch)

Materials

- Casing : Plastic (Black UL94V-0)
- Impeller : Plastic (Black UL94V-0)
- Bearing : Ball Bearing
- Lead Wire : UL3443 AWG24
 - (+) : Red (-) : Black
 - PWM : Brown Tach : White

Outline

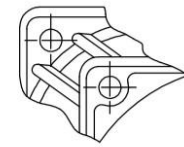
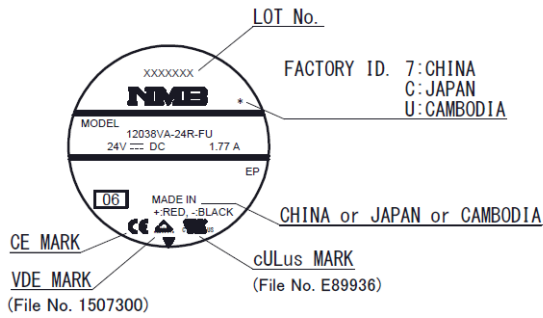

FLANGE TYPE

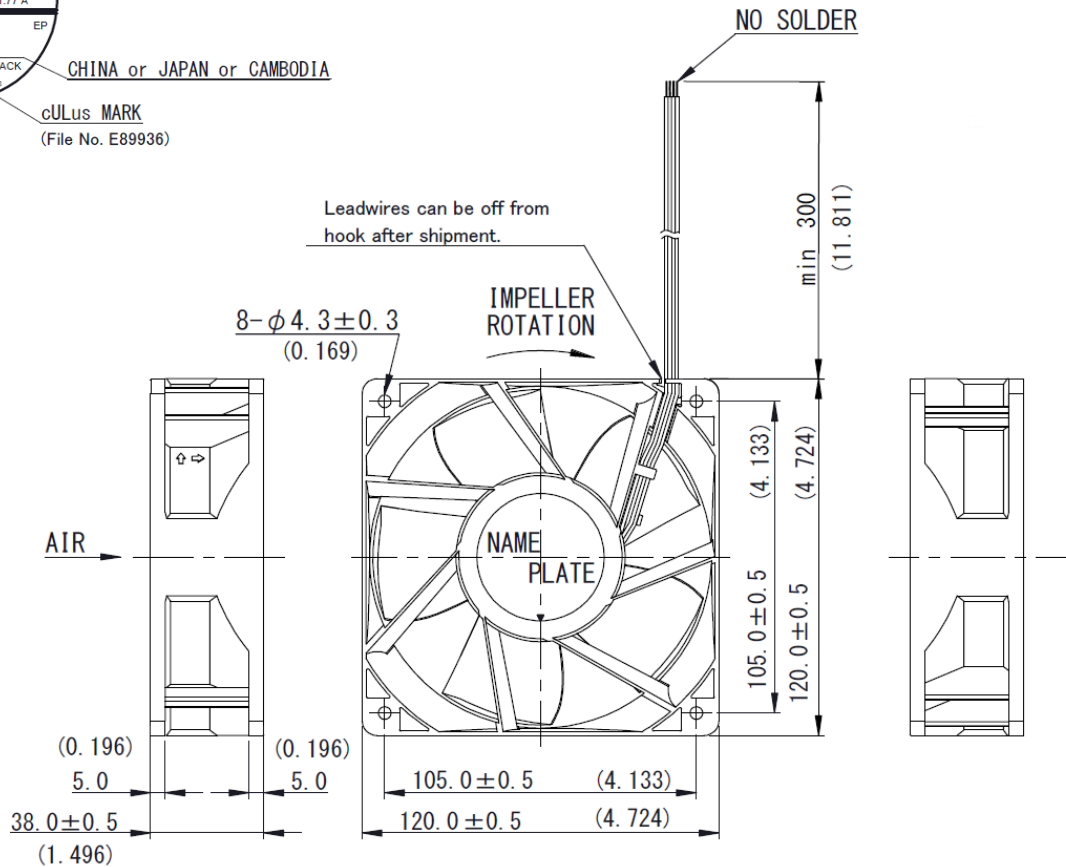

Unit: mm (inch)

General Specifications

Motor Protection:

Auto Restart/Polarity Protection

Insulation Resistance:

10M Ω or over with a DC500V Megger

Dielectric Withstand Voltage: AC 700V 1s

Allowable Ambient Temperature Range:

-10°C ~ +60°C (Operating)

-40°C ~ +60°C (Storage)

IP Code: IP69K

Expected Life

25°C 100,000 Hours (L10)

Material

Casing : Plastic (Black) UL94V-0

Impeller : Plastic (Black) UL94V-0

Bearing : Ball Bearing

Lead Wire : UL10368, AWG22, +Red, -Black

Panel Cut-Outs

Units: $\frac{\text{inch}}{\text{(mm)}}$

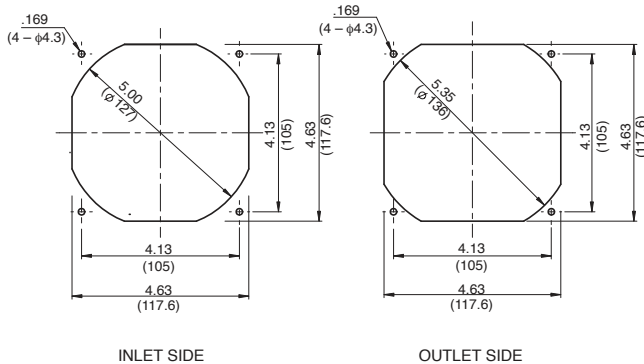

Characteristic Curves

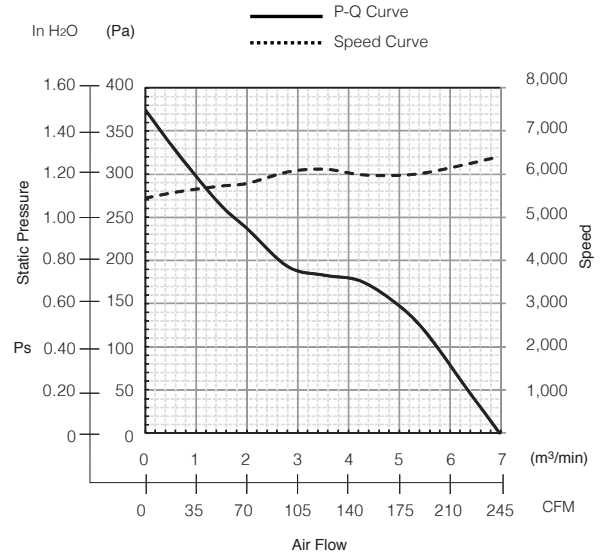

Outline

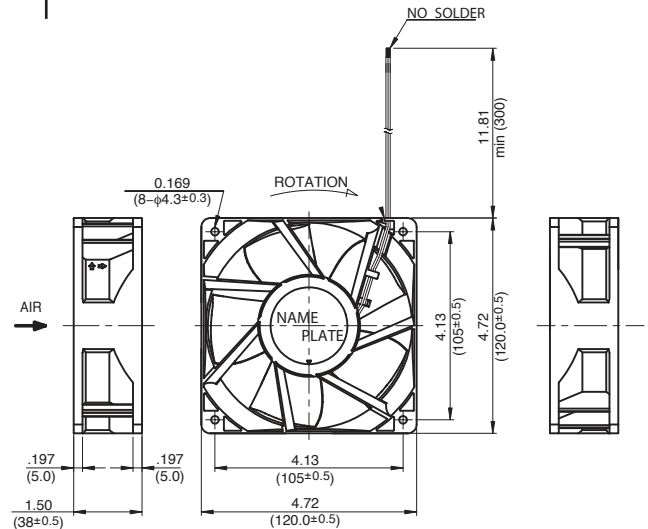

Specifications

MODEL	Rated Voltage	Operating Voltage	Current	Input Power	Speed	Max. Air Flow		Max. Static Pressure		Noise	Mass
	(V)	(V)	(A) ^{*1}	(W) ^{*1}	(min ⁻¹) ^{*1}	CFM ^{*1}	(m ³ /min) ^{*1}	in H ₂ O	(Pa) ^{*1}	(dB) ^{*1}	(g)
12038VA-24R-GA-00	24	18.0 ~ 27.6	1.48	35.5	6400	243.67	6.9	1.48	370	64.0	370

Rotation: Clockwise

Airflow Outlet: Air Out Over Struts

*1: Average Values in Free Air

Note: PWM/Locked Rotor/Tach Available