

THIS DRAWING IS UNPUBLISHED. RELEASED FOR PUBLICATION 1825516, 1825516
 © COPYRIGHT 1825516y - ALL RIGHTS RESERVED.

REVISIONS					
P	LTR	DESCRIPTION	DATE	DWN	APVD
C		REVISED PER ECR-16-014236	21OCT2016	RK	SS

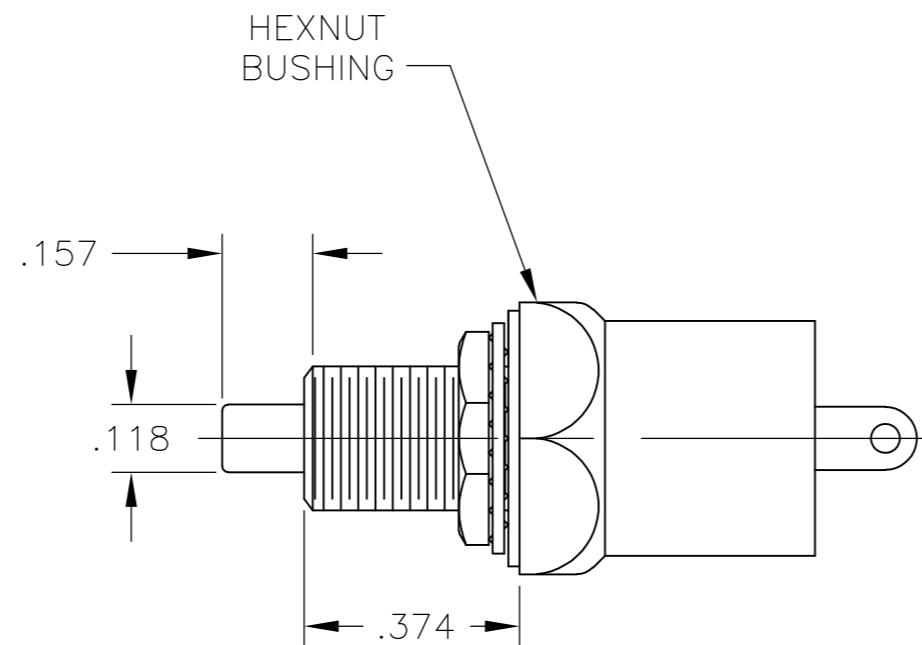
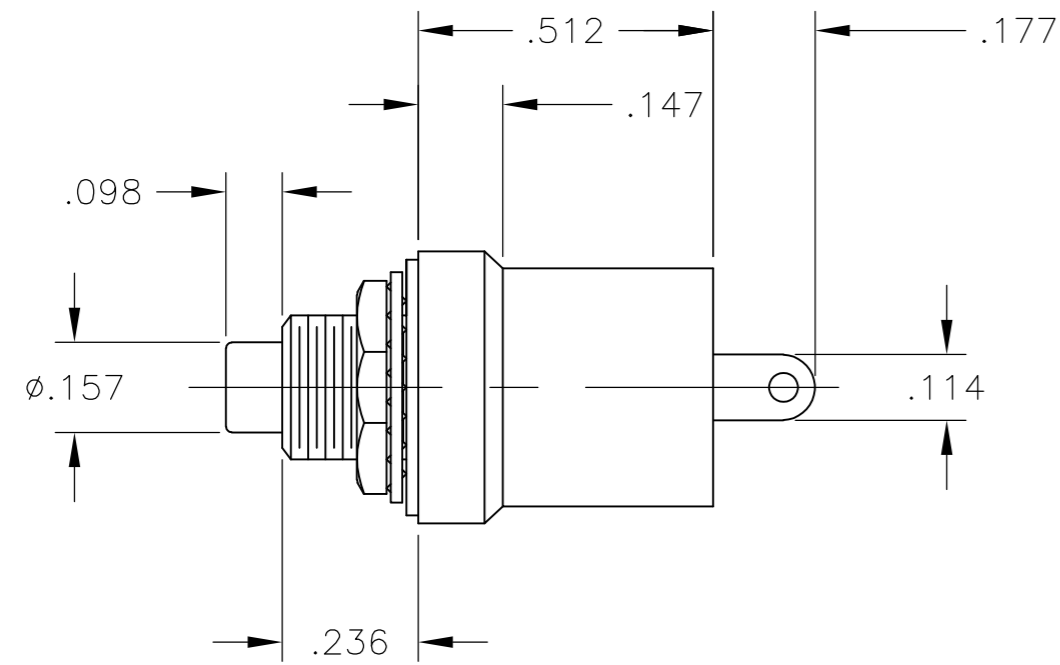

MSP103C204 ONLY

1. ALL MATERIAL AND FINISHES COMPLY WITH EC DIRECTIVE 2002/95/EC OF 27JAN2003 (ROHS)

SPECIFICATIONS	
CONTACT RATING	MIN. 100mA @ 5VAC/DC MAX. 3A @ 125VAC
INITIAL CONTACT RESISTANCE	20MILLIOHMS MAX AT 1A, 2-4 VDC
INSULATION RESISTANCE	100 MEGAOHMS MIN AT 500VDC
DIELECTRIC STRENGTH	1000 VAC, 1 MINUTE
ELECTRICAL LIFE	5000 OPERATIONS
OPERATING TEMPERATURE	-20°C TO 80°C
STORAGE TEMPERATURE	-20°C TO 80°C
RECOMMENDED SOLDER TEMP.	HAND SOLDER 280°C MAX, 3 SECONDS MAX.

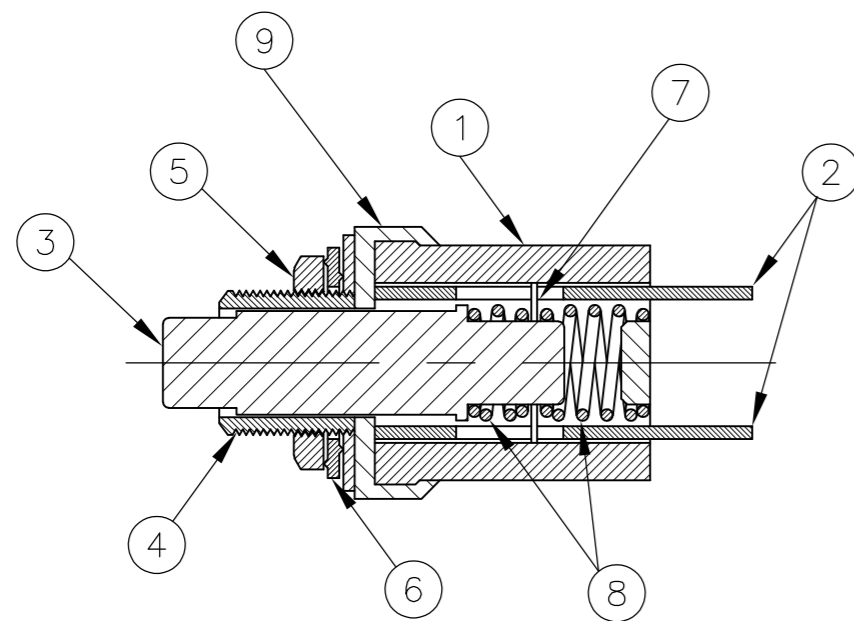
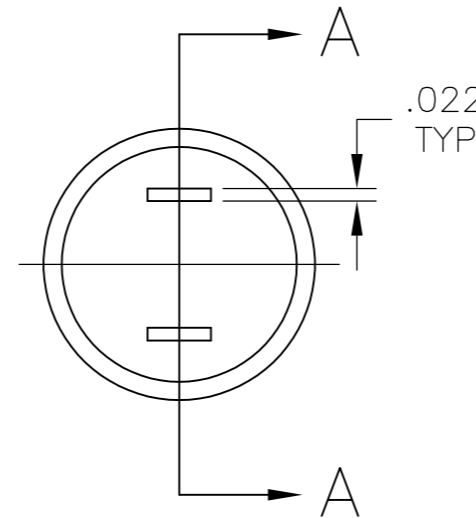
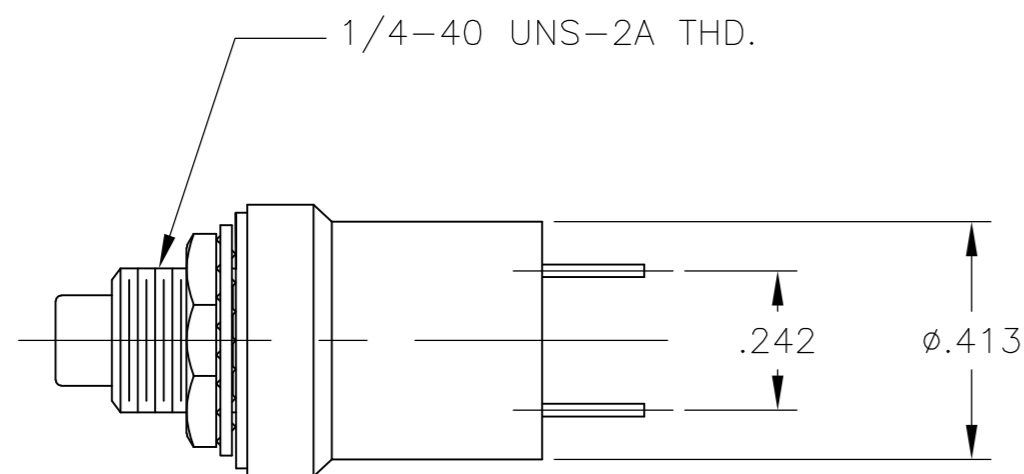
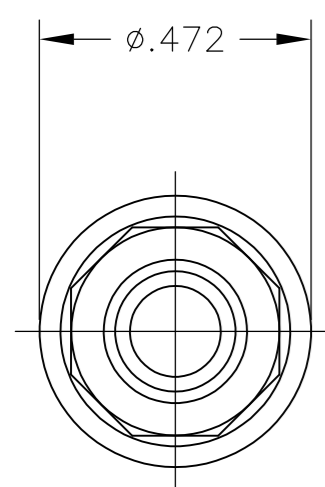

SECTION A-A

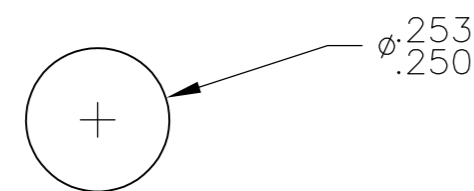

RECOMMENDED PANEL CUTOUT

MATERIAL CHART				
ITEM	COMPONENT	BASE MATERIAL	FINISH	QTY
1	CASE	PHENOL RESIN, BLACK, UL94-HB		1
2	TERMINAL	COPPER ALLOY	SILVER	2
3	ACTUATOR BUTTON	POLYCARBONATE RESIN, UL94V-2		1
4	BUSHING	BRASS	NICKEL	1
5	HEX. NUT	BRASS	NICKEL	1
6	LOCKWASHER	STEEL	ZINC	1
7	MOVABLE CONTACT	COPPER ALLOY	SILVER	1
8	SPRING	MUSIC WIRE	OIL TREATED	2
9	INSULATING PLATE	PAPER PHENOL RESIN, NATURAL, UL94HB		1

SPST	NO	RED	MSP103C204	1825516-4
SPST	NO	BLACK	MSP103C004	1825516-3
SPST	NO	RED	MSP103C04	1825516-2
SPST	NC	BLACK	MSP103B04	1825516-1
TYPE	MOMENTARY ACTION	ACTATOR BUTTON COLOR	ALCO P/N	P/N

THIS DRAWING IS A CONTROLLED DOCUMENT.		DWN M. ZITTO 01DEC05		
DIMENSIONS: INCHES		CHK M. ZITTO 01DEC05		
TOLERANCES UNLESS OTHERWISE SPECIFIED:		APVD M. ZITTO 01DEC05	NAME SWITCH, PUSHBUTTON MSP103, SILVER	
0 PLC ± - 1 PLC ± - 2 PLC ± - 3 PLC ± .005 4 PLC ± - ANGLES ± 1°		PRODUCT SPEC	RESTRICTED TO	
MATERIAL SEE TABLE		FINISH SEE TABLE	SIZE A2	CAGE CODE -
		WEIGHT	DRAWING NO 1825516	SCALE 3:1
		CUSTOMER DRAWING	SHEET 1 of 1	REV C