

CUSTOMER PRINT

PART NUMBER: 17982-XSG-300

ASS'Y P/N	CONTACT QTY.	KEY STYLE
17982-5SG-300	5 - # 26	A-KEY
17982-6SG-300	6 - # 26	B-KEY
17982-7SG-300	7 - # 26	A-KEY

NUMBER OF CONTACTS

- NOTES:
1. ALL PARTS ARE TO BE BULK PACKED.
 2. CONTACTS ARE ASSEMBLED INTO PANEL CONNECTOR.
 3. SOLDER CUPS ARE TO BE FACING OUTWARD RADIALLY. CENTER CONTACT SHOULD BE FACING BETWEEN POSITIONS 1 & 6.
 4. ALL DIMENSIONS ARE REFERENCE EXCEPT THOSE WITH A TOLERANCE.

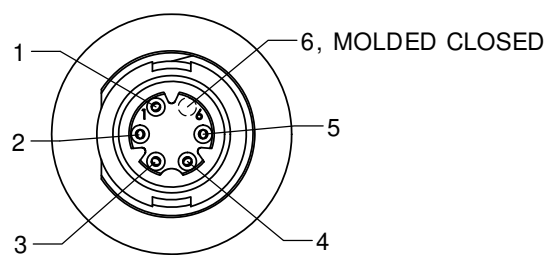

FACE VIEW
17982-5SG-300
5 POSITION
A-KEY

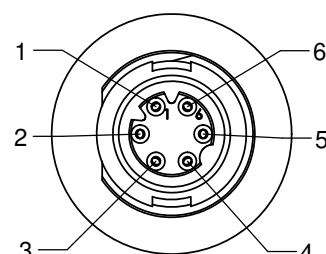

FACE VIEW
17982-6SG-300
6 POSITION
B-KEY

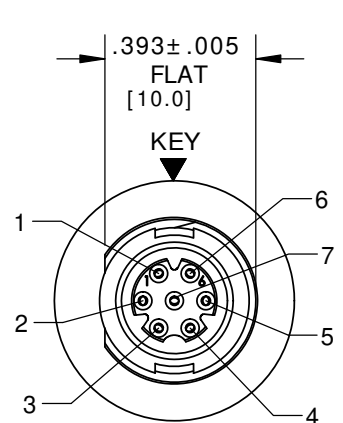

FACE VIEW
17982-7SG-300
7 POSITION
A-KEY

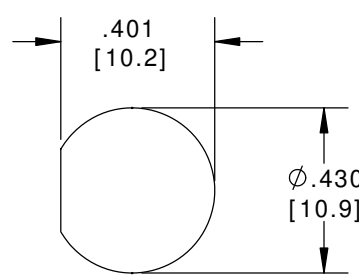

RECOMMENDED
PANEL CUT-OUT
TOLERANCE: ±.003

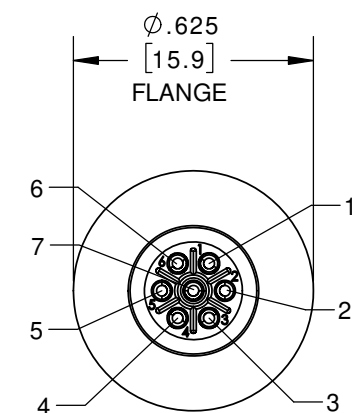
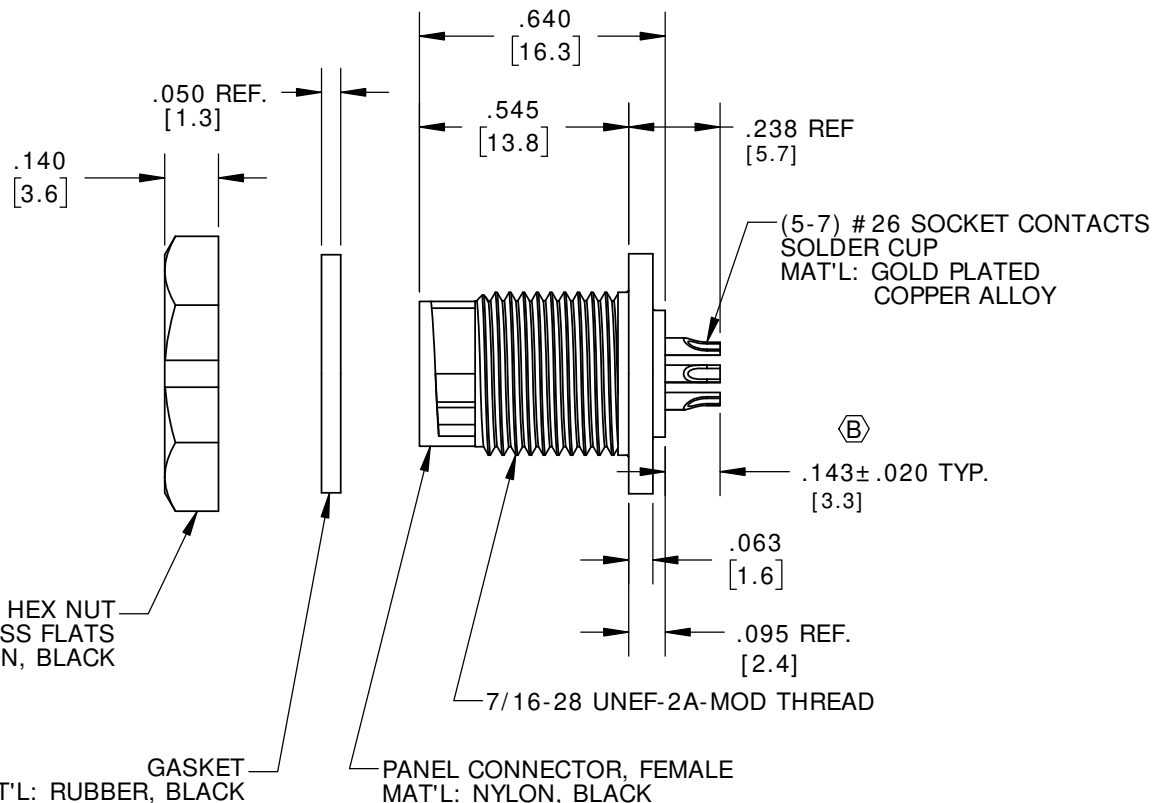

WIRE VIEW
SHOWN 17982-7SG-300

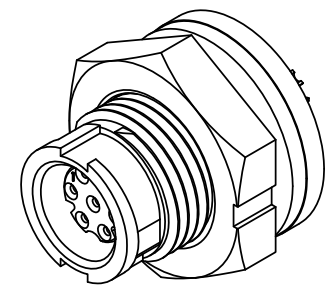

DIMENSIONS IN BRACKET [] ARE METRIC.

CUSTOMER APPROVAL

THIS DOCUMENT CONTAINS CONFIDENTIAL INFORMATION PROPRIETARY TO CONXALL CORPORATION. ANY REPRODUCTION, DISCLOSURE, OR USE OF THIS DOCUMENT / INFORMATION IS EXPRESSLY PROHIBITED UNLESS AUTHORIZED IN WRITING BY CONXALL CORPORATION.

APPROVED BY: _____
DATE: _____

RoHS COMPLIANT

B	MA	10-27-17	CONTACT LOCATION DIM WAS .130 ±.010 PER ECR 9211 #1
A	AN	11-07-11	DRAWING CREATED PER DOR 11-E149SL
REV.	INIT.	DATE	DESCRIPTION
	PAK	07/19/11	ALL INFORMATION ILLUSTRATED IS THE PROPERTY OF CONXALL CORPORATION. UNAUTHORIZED DUPLICATION OR DISTRIBUTION OF THIS DOCUMENT IS PROHIBITED.
APPROVED BY:			 601 E. WILDWOOD VILLA PARK, IL 60181 TITLE: PANEL CONNECTOR ASSEMBLY #26 SOCKET CONTACTS, SOLDER TAIL MICRO-CON-X, A-KEY & B-KEY STANDARD PRODUCT
SCALE	SIZE	SHEET	
NTS	B	1 OF 1	CUSTOMER:
FILE:	DIRECTORY:	PART NUMBER:	REV
17982-XSG-300	SLW	17982-XSG-300	B